

Features

Cast Iron Gear Case with Helical Gears

A 540 RPM operating speed makes for effective operation.

Voltmeter

A large 3" voltmeter ensures the proper output.

Premium Square D Circuit Breakers

Square D is the industry leader in circuit breaker protection.

Protective PTO Shield

Safety is always a priority.

5-Wire Anderson Full Power Plug Included

You supply the appropriate length of fine-stranded copper wire, we provide the plug.

100% Load Tested

You won't find statistical sampling here. We load test every generator before it leaves our facility.

POWER TAKE-OFF

45,000 Continuous Watts

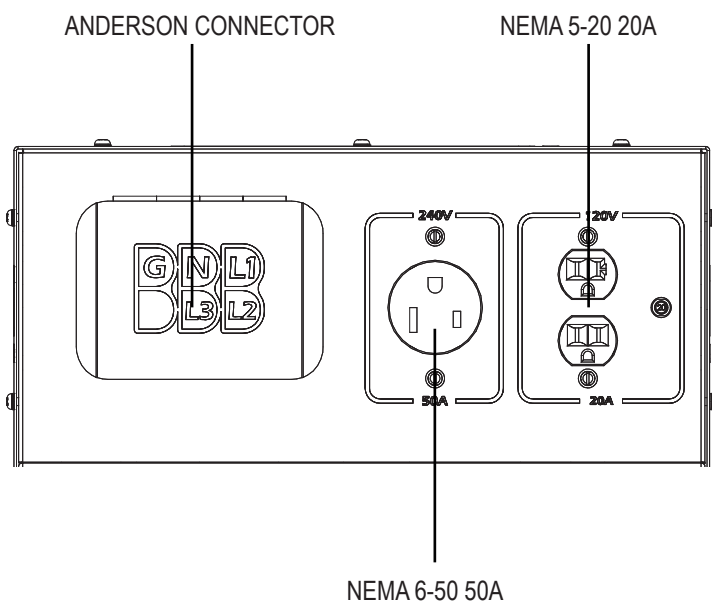

Optional Accessories

PTO Drive Shaft

1 3/8" - 6 spline x 1 3/8" - 6 spline quick connect shaft. Designed to handle the horsepower ratings required.

Off-Road PTO Trailer

Our steel trailers are specifically designed to handle the torque of running a PTO generator.

1000 RPM Gearcase Upgrade

Factory installed

Manual Transfer Switch

Set up your generator quickly and safely to restore power to critical circuit breakers.

45PTOC-4

| | |
|----------------------------------|------------------------|
| CONTINUOUS WATTS | 45,000 |
| AMPS ⁽¹⁾ | 108 |
| OUTPUT | 120/240 V |
| PHASE | THREE |
| PTO INPUT SPEED | 540 RPM ⁽²⁾ |
| INPUT SHAFT SIZE | 1 3/8" - 6 SPLINE |
| REQUIRED INPUT HP ⁽³⁾ | 90 |
| MOTOR STARTING ⁽⁴⁾ | 20 HP |
| VOLTMETER | YES |
| MAIN CIRCUIT BREAKER | 100 AMP |
| NEUTRAL BONDED | YES |
| GROUND LUG | YES |
| GEARCASE OIL | SAE 85W 90-140 |
| GEARCASE OIL CAPACITY | 1 PINT |
| LIFTING EYE | YES |
| WARRANTY ⁽⁵⁾ | 3 YR |

NOTES: (1) Unity (1.0) power factor (2) Factory installed 1000 RPM upgrade available (3) Required HP at PTO of tractor for full rated output. Each 2 HP of tractor power equals approximately 1 kW of electric power. (4) Code G capacitor start motor. (5) 3 year warranty for farm use only, other uses have a 1 year warranty. Please consult factory or authorized dealer for further information.

GENERATOR END

| | |
|---------------------------|------------------------|
| VOLTAGE REGULATION | +/- 5% |
| TOTAL HARMONIC DISTORTION | N/A |
| RATING | 125° C |
| TYPE | 4 POLE REVOLVING FIELD |
| BRUSHED | YES |
| GENERATOR SPEED | 1800 RPM |
| VOLTAGE CONTROL | BUCK BOOST TRANSFORMER |
| INSULATION | CLASS F |

RECEPTACLES

| | |
|-----------------------|--------------------------|
| 120 VOLT RECEPTACLES | (1) NEMA 5-20 20A DUPLEX |
| 240 VOLT RECEPTACLES | (1) NEMA 6-50 50A |
| 120/240 VOLT ANDERSON | 175 AMPS |

SHIPPING

| | |
|---------------------|-------------------------|
| DIMENSIONS (LxWxH) | 38" x 23" x 20" |
| NET WEIGHT | 548 LBS |
| SHIPPING DIMENSIONS | 44.25" x 28.5" x 28.25" |
| SHIP WEIGHT | 558 LBS |
| FREIGHT CLASS | 65 |

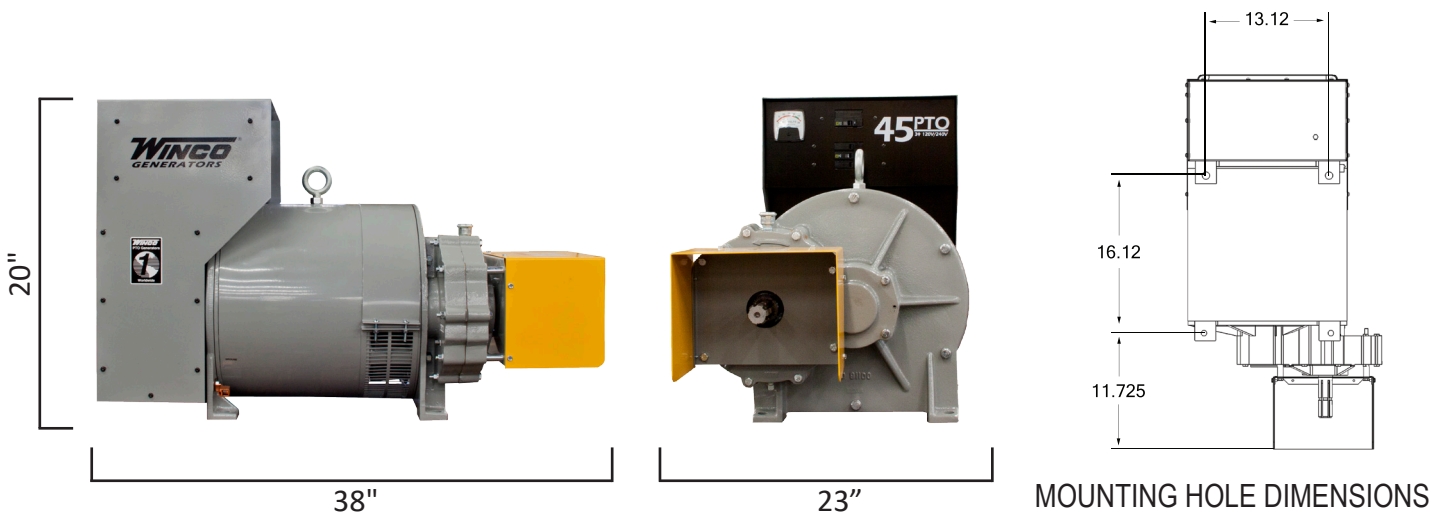

Specifications are subject to change without notice.
 225 S. Cordova Ave Le Center MN • 1-800-733-2112 • www.wincogen.com