

WINCO[®] INC

ILLUSTRATED PARTS LIST

DL6000H/C (Recoil Start)

DL6000HE/D (Electric Start)

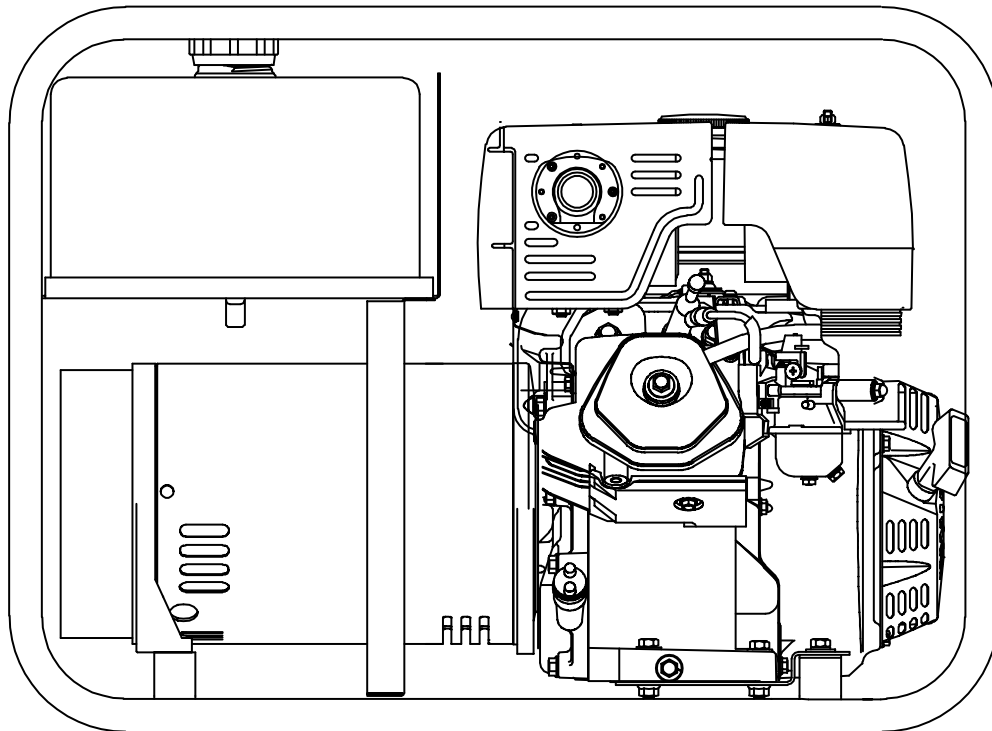

ENGINE & GENERATOR ASSEMBLY

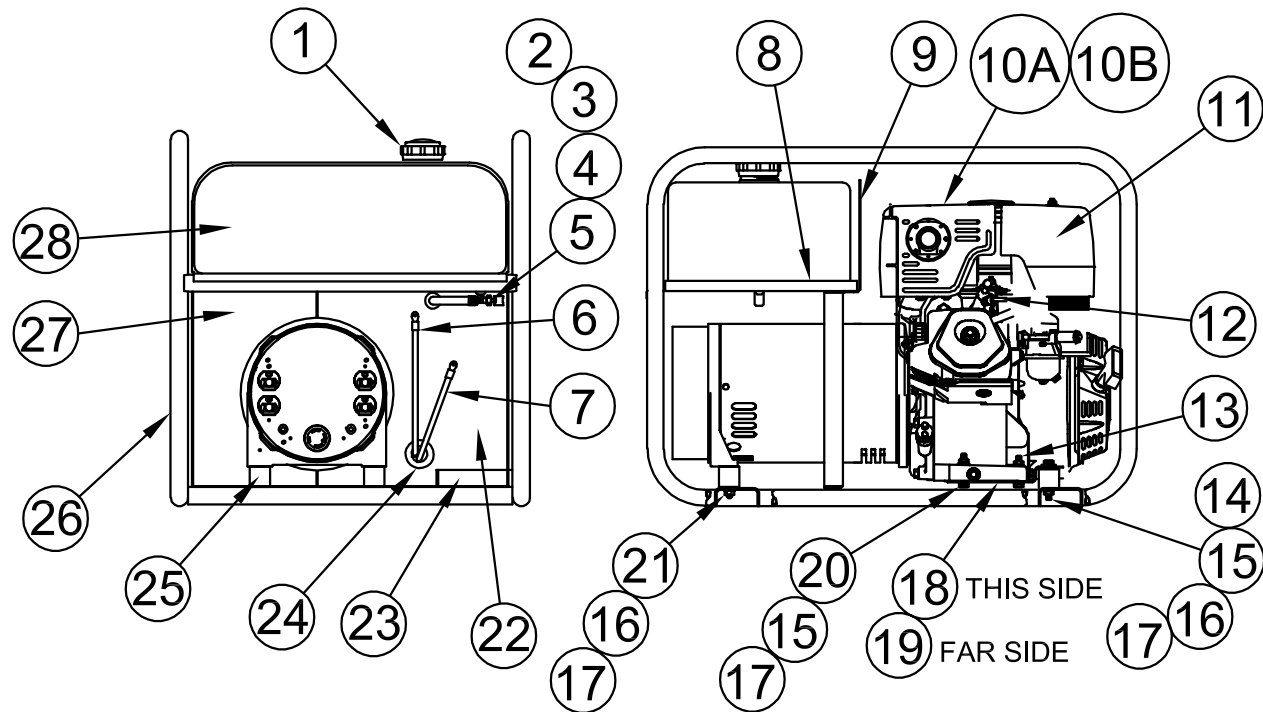

REF #	PART NUMBER	QTY	DESCRIPTION
1	15482-000	1	Fuel Cap
2	56879-000	1	90° Elbow
3	81018-009	1	Clamp
4	62999-001	2	Fuel Hose Clamp
5	40078-013	1	Fuel Hose
6	15767-007	1	Negative (-) Battery Cable
7	15767-006	1	Positive (+) Battery Cable
8	15462-012	1	Fuel Tank Tray
9	58684-007	1	Edge Trim
10A	15467-000	1	Honda Engine, Recoil Start Model GX340 RT1VDE2
10B	15428-000	1	Honda Engine, Electric Start Model GX340 RT1VWE2
11	17210-ZE3-010	1*	Air Filter Element
12	BRP6ES	1	NGK Spark Plug
13	468-000	2	5/16"-18 X 1-12" Bolt
14	467-000	2	5/16"-18 X .63" Bolt
15	526-000	4	Flat Washer

REF #	PART NUMBER	QTY	DESCRIPTION
16	480-000	4	5/16" Split Washer
17	16249-000	8	5/16" Lock Nut
18	15929-002	1	Adapter Bracket
19	15929-001	1	Adapter Bracket
20	9416-000	2	5/16"-18 X 1.75" Bolt
21	1116-000	2	5/16"-18 X 1" Bolt
22	15222-016	1	Right Support Panel
23	15676-001	1	Battery Tray
24	62786-000	1	Grommet
25	64062-000	4	Shock Mounts
26	63073-011	1	Cradle
27	15223-014	1	Left Support Panel
28	64024-000	1	4.5 Gal. Fuel Tank
NI	97391-002	2	Cushioned Clamp
NI	62496-000	1	Fuel Filter
NI	15679-002	1	Governor Cover Plate
NI	62999-005	1	Hose Clamp
NI	15807-000	1	Battery Hold Down Kit
NI	Not Illustrated		
*	Honda Part #		

END COVER ASSEMBLY

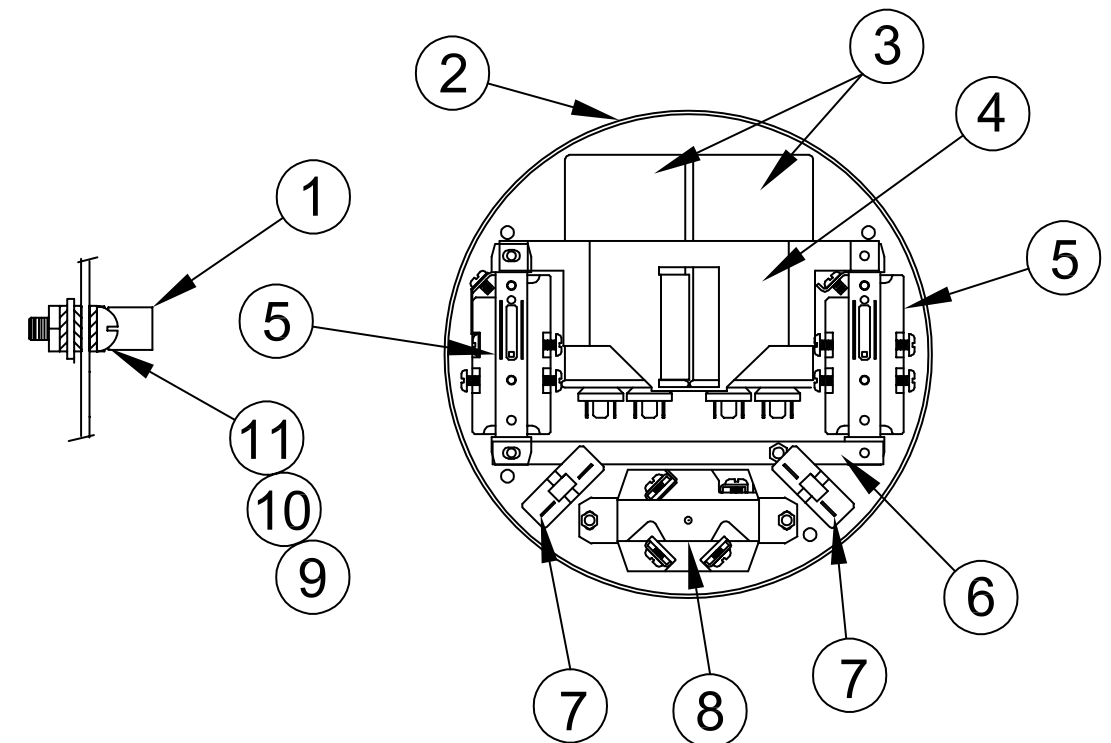

END COVER ASSEMBLY

REF #	PART NUMBER	QTY	DESCRIPTION
1	48042-001	1	Ground Lug
2	15050-002	1	End Cover
3	15051-000	2	Capacitor, 40mfd, 370VAC
4	15088-000	1	Capacitor Strap
5	50766-000	2	20A 120V Receptacle
6	64045-029	1	Mounting Strap
7	91286-006	2	25A Circuit Breaker
8	97360-000	1	30A 120/240V Receptacle
9	419-000	1	#10-24 X 1/2" Screw
10	21975-000	3	#10 Lock Washer
11	456-000	1	#10-24 Nut
NI	15750-000	1	Decal, Ground
NI	41387-009	1	Ground Strap
NI	Not Illustrated		

GENERATOR ASSEMBLY

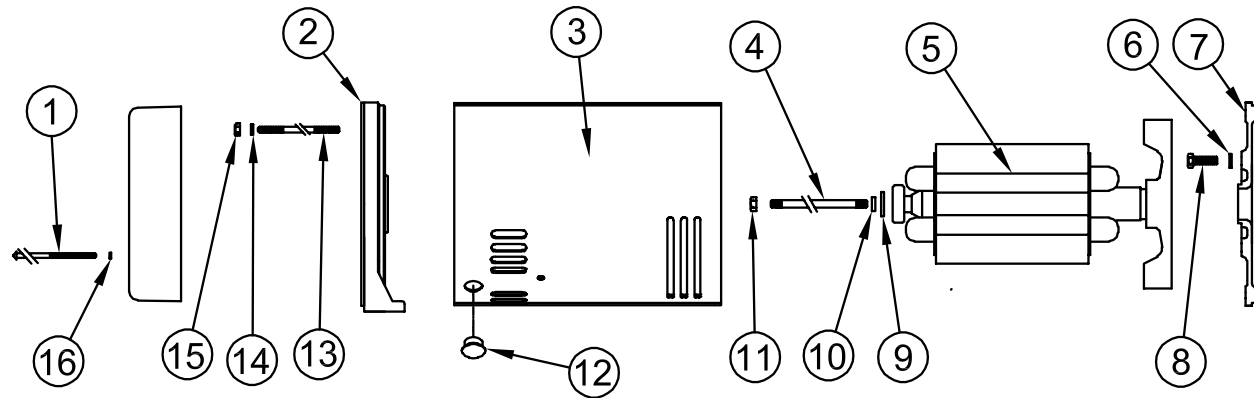

REF #	PART NUMBER	QTY	DESCRIPTION
1	15013-000	4	Screw
2	15015-002	1	Bearing Bracket
3	15042-005	1	Stator Assembly
4	23197-009	1	Stud Bolt 5/16" - 24
5	15045-007	1	Rotor Assembly
6	481-000	4	Lock Washer
7	15008-001	1	Engine Bracket
8	91658-003	4	Bolt
9	23558-000	1	Washer
10	480-001	1	Lock Washer

REF #	PART NUMBER	QTY	DESCRIPTION
11	15193-000	1	5/16" - 24 Nut
12	15102-001	1	Hole Plug
13	15068-008	4	Stud Bolt 5/16" - 20
14	479-000	4	Lock Washer
15	15192-00	4	1/4" - 20 Nut
16	21975-000	4	Lock Washer
NI	15047-001	1	Diode, Standard Polarity
NI	15047-002	1	Diode, Reverse Polarity
NI	Not Illustrated		

WIRING DIAGRAM

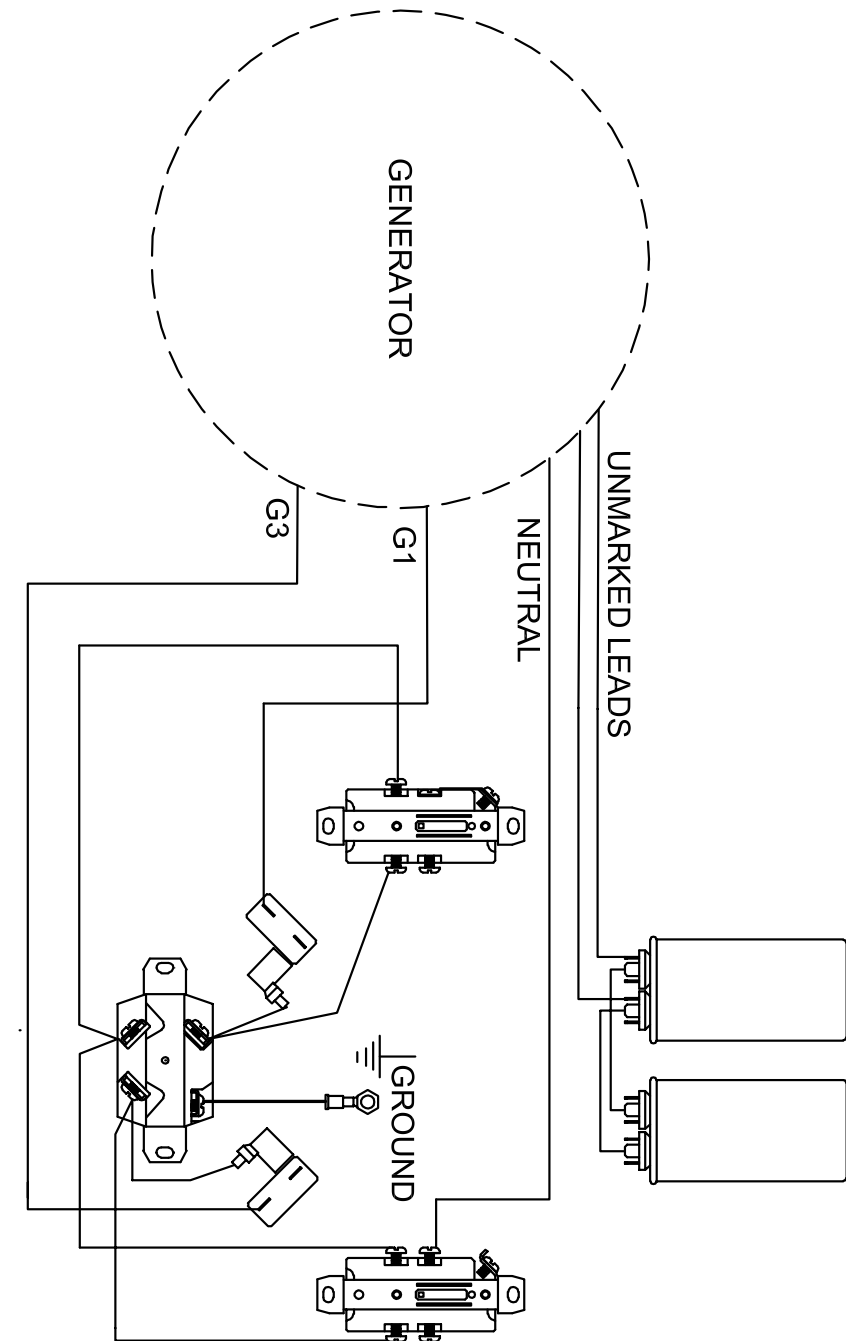

DECALS

REF #	PART NUMBER	QTY	DESCRIPTION
NI	64891-002	1	EVP Emissions
NI	64918-000	2	Danger Carbon Monoxide
NI	63941-001	1	Hot Warning
NI	15209-000	1	Danger Decal Set
NI	15370-016	1	Model Decal
NI	15370-000	1	Dyna Decal
NI	Not Illustrated		

WINDING SPECIFICATIONS

Rotor Resistance	0.95 to 1.05 Ohms
G1 to N Resistance	0.21 to 0.23 Ohms
G3 to N Resistance	0.22 to 0.25 Ohms
Capacitor Leads Resistance	0.53 to 0.58 Ohms
AC Residual Voltage	7VAC G1 to N
Winding Spec	SS1532

WINGO INC[®]
A Division of **DT** Dyna Technology Inc

225 S. CORDOVA AVE.
LECENTER, MN 56057
507-357-6821
SERVICE DEPT.
507-357-6831