

# **WINCO<sup>®</sup> INC**

## **ILLUSTRATED PARTS LIST**

### **WC10000VE/E WC10000VE/F**

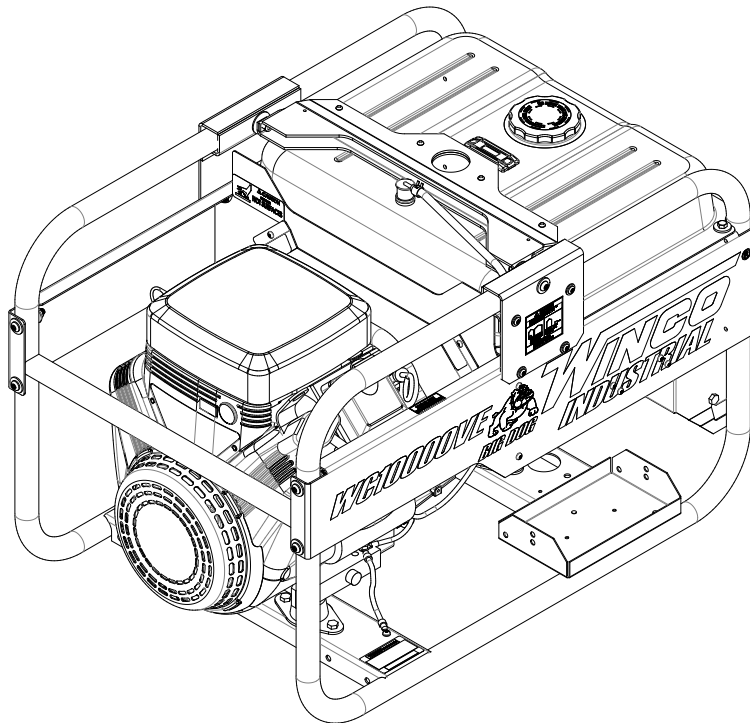

**WINCO INC.  
225 S. CORDOVA AVE.  
LE CENTER, MN 56057  
(507) 357-6821  
SERVICE DEPT.  
(507) 357-6831  
wincogen.com**

# ENGINE / GENERATOR ASSEMBLY

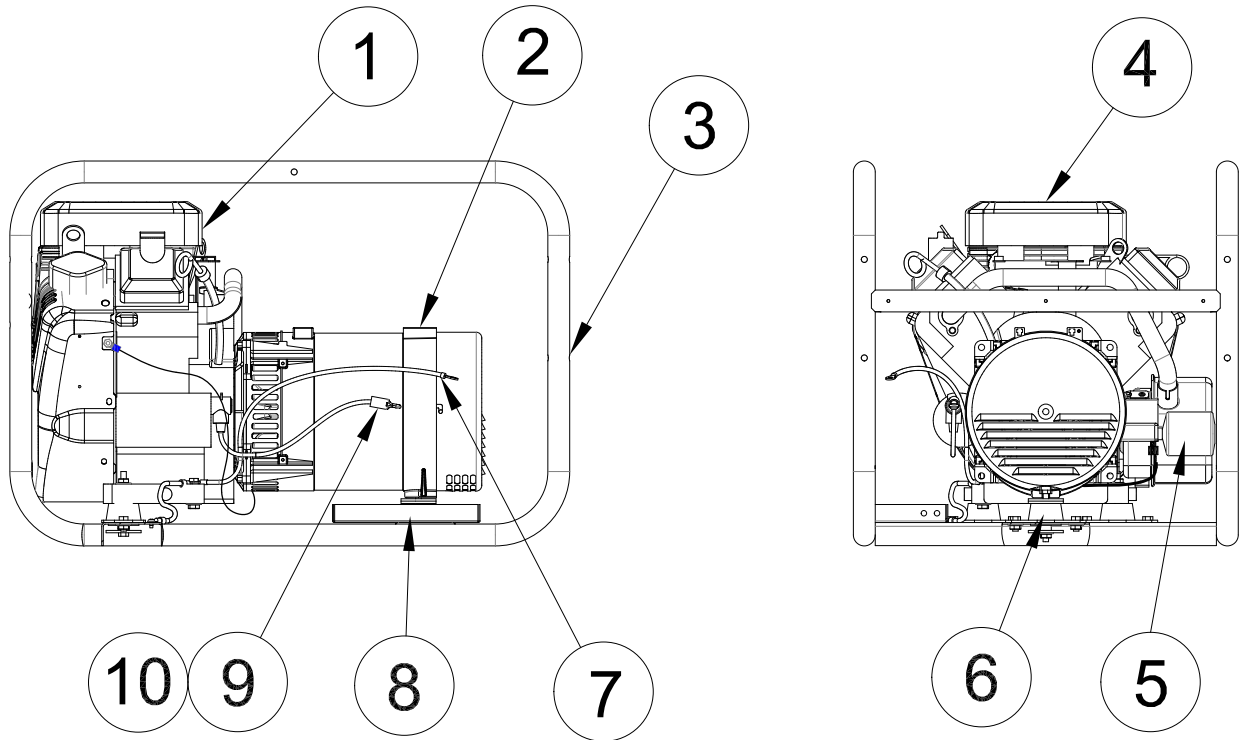

REF #	PART NUMBER	QTY	DESCRIPTION
1	15461-000	1	Engine, Briggs & Stratton Model: 356447-0006-G1
2	16346-004	1	Generator, Mecc Alte Spa Model: S20W-130/A
3	63073-044	1 (see note)	Cradle Assembly
4	394018	1*	Air Filter
	272490	1*	Air Filter Pre-Cleaner
5	492932	1*	6 cm long Oil Filter
	491056	1*	9 cm long Oil Filter
6	98807-000	3	Shock Mount
7	15767-009	1	Battery Negative (-) cable
8	15676-006	1	Battery Tray
9	15767-010	1	Battery Positive (+) cable
10	16145-000	1	Terminal Insulator
NI	491055	2*	Spark Plug
NI	493629	1*	Fuel Filter
NI	15807-002	1	Battery Hold Down Kit

\* Briggs & Stratton Part #  
NI Not Illustrated

Note: If replacing cradle on /F model you must replace the side rails with /E side rails.

# RECEPTACLE PANEL ASSEMBLY FRONT VIEW

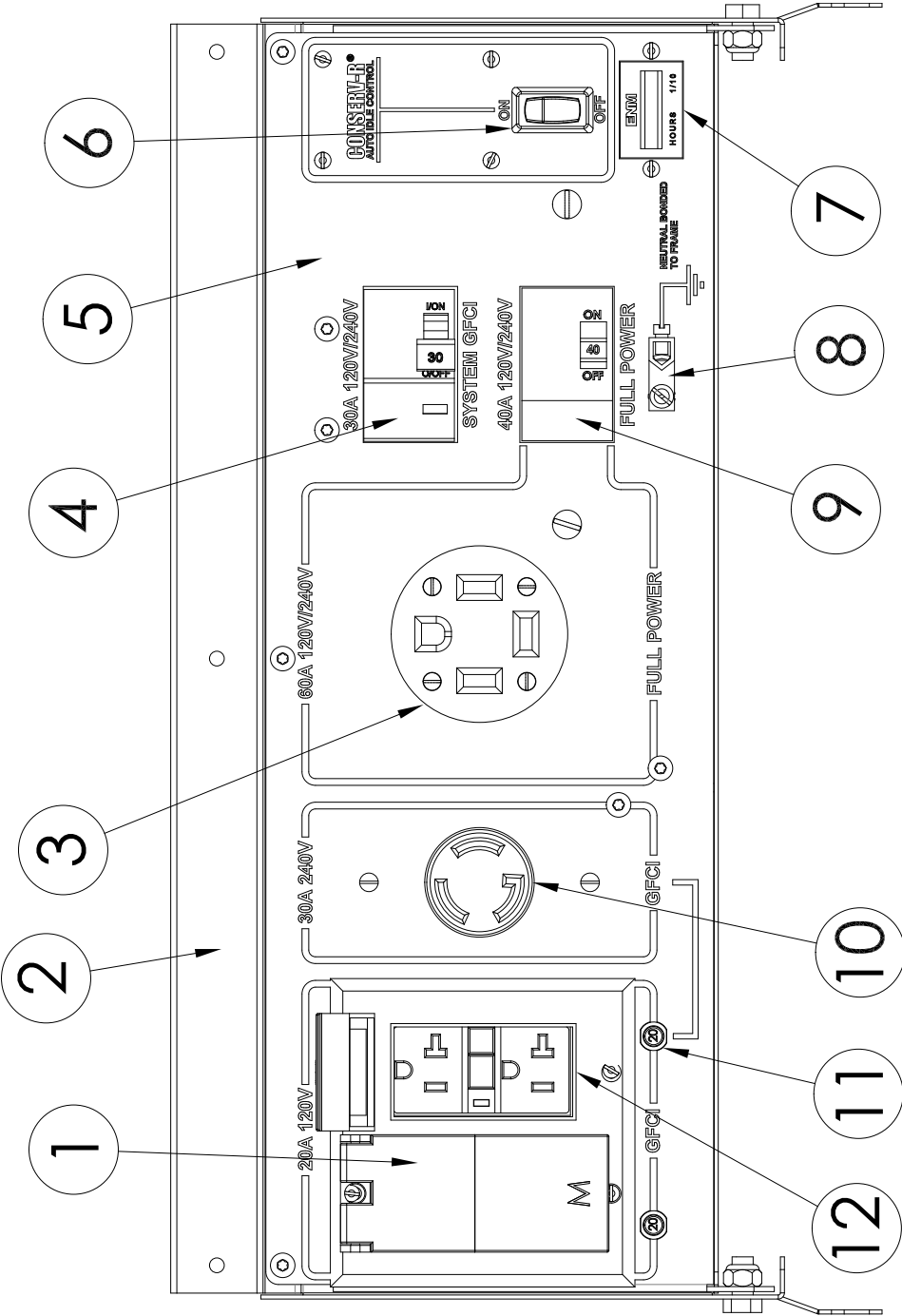

REF #	PART NUMBER	QTY	DESCRIPTION
1	15620-007	1	2 Gang GFCI Cover
2	15221-027	1	Back Panel
3	300136	1	NEMA 14-60R Receptacle
4	16488-000	1	30A 240 V GFCI Circuit Breaker
5	15458-032	1	Front Panel
6	64089-000	1	SPST Rocker Switch
7	58166-001	1	Running Time Meter
8	48042-001	1	Ground Lug
9	57030-008	1	40A 240V Circuit Breaker
10	57324-000	1	NEMA L6-30R Receptacle
11	91286-001	2	20A 1 Pole Circuit Breaker
12	15147-001	2	NEMA 5-20R GFCI Recpt.

## RECEPTACLE PANEL ASSEMBLY REAR VIEW

REF #	PART NUMBER	QTY	DESCRIPTION
1	300042-1	1	Idle Control Module
2	16319-000	1	Mounting Bracket
3	16385-000	1	Idle Control Transformer
4	16346-312	1*	40 mf Capacitor
4	16346-412	1**	45 mf Capacitor
5	64045-041	2	Mounting Strap
NI	62486-000	1	Grommet
NI	Not Illustrated		
*	Revisions 1 & A (before 6-2013)		
**	Revision A (after 6-2013) & Revisions B & C		

# RECEPTACLE PANEL ASSEMBLY REAR VIEW

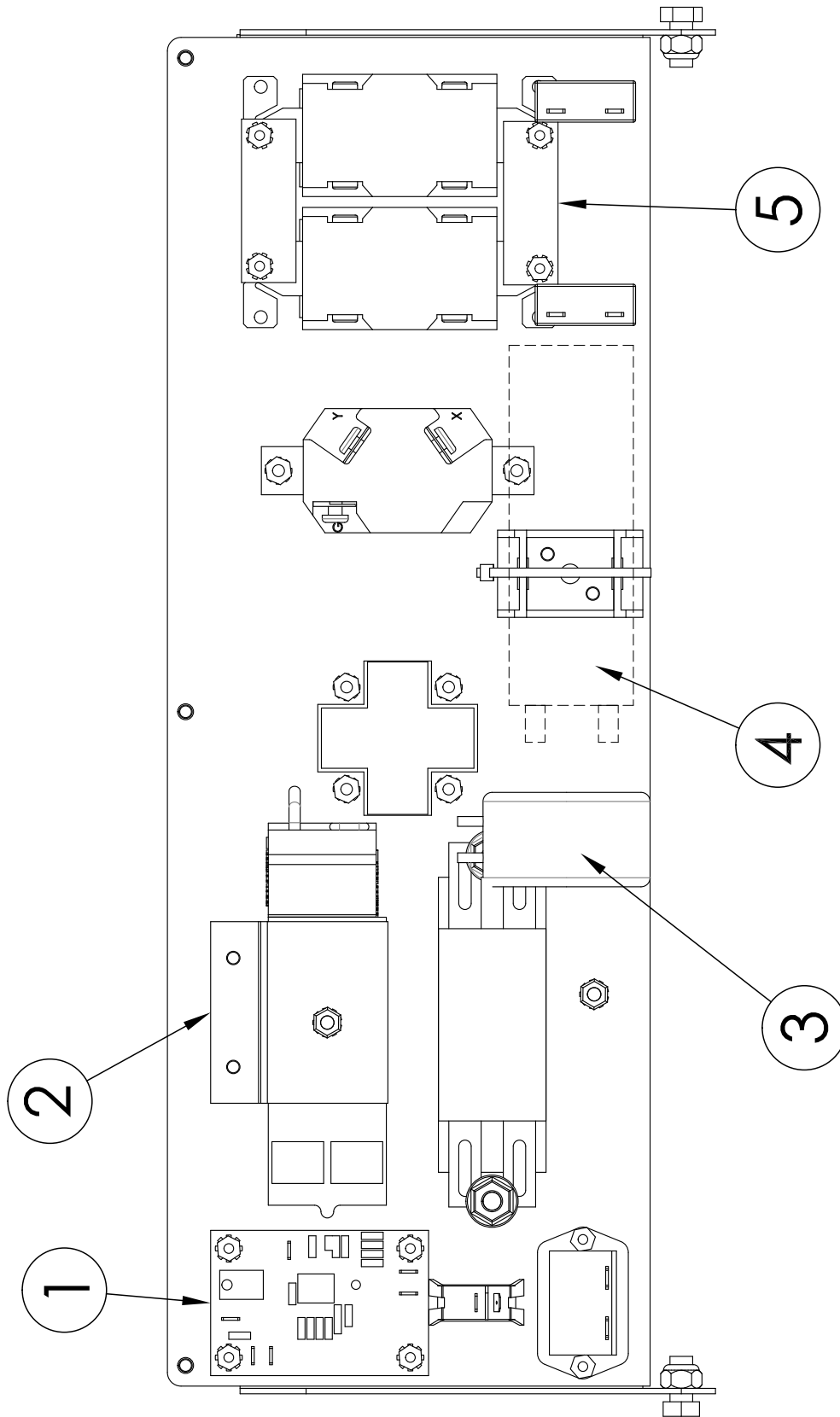

# FUEL SYSTEM ASSEMBLY

NOTE: CUT FUEL LINE BETWEEN FUEL PUMP AND FUEL FILTER  
INSERT ON/OFF FUEL VALVE IN BETWEEN USING .50"  
HOSE CLAMPS

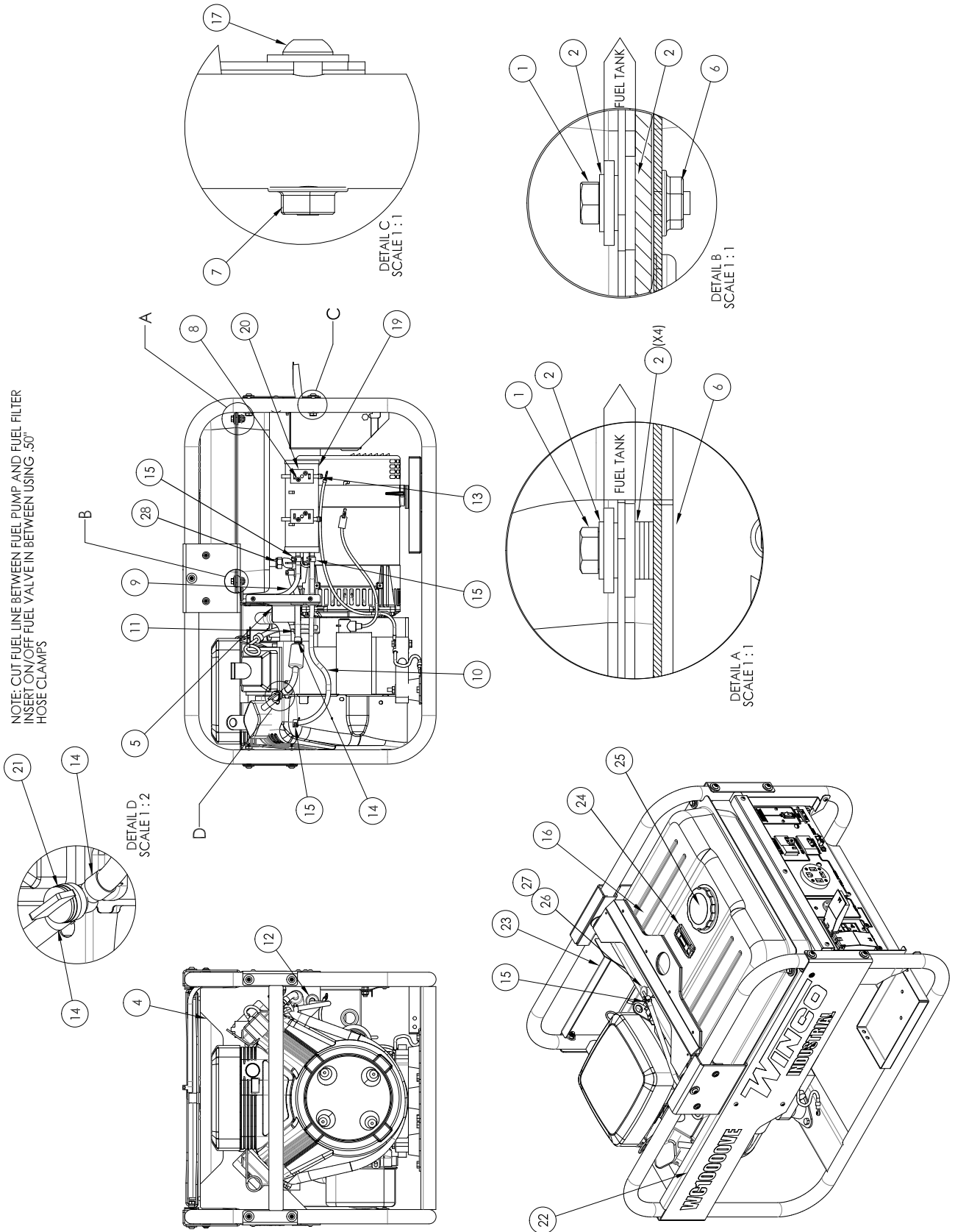

REF #	PART NUMBER	QTY	DESCRIPTION
1	439-000	4	.25" X 1" Bolt
2	512-000	14	.25" Washer
3	526-000	8	.365 id .890 od Washer
4	15464-017	1	Generator Divider
5	15687-010	1	Heat Shield
6	16248-000	4	.25-20 Flange Nut
7	16249-000	8	5/16" – 18 Flange Nut
8	21698-001	10	Torx Screw
9	40077-000	20"	3/16" Fuel Hose
10	40077-000	14"	3/16" Fuel Hose
11	40078-000	9"	¼" Fuel Hose
12	40730-000	3	Grommet
13	49975-013	2	Cable Tie
14	62999-001	4	.5" od Red Hose Clamp
15	62999-005	4	.41" od Green Hose Clamp
16	64024-013	1*	7 Gallon Steel Fuel Tank
*	Slosh valve with grommet (80903-002) is used with this fuel tank.		
17	64858-004	4	Cap Screw
18	64858-005	4	Cap Screw
19	80902-000	1	Carbon Canister
20	81902-000	1	Mounting Bracket
21	98771-005	1	Fuel Valve
22	300216-6	1	Left Side Rail (/E)
22	300216-21	1 (see note)	Left Side Rail (/F)
23	300217-6	1	Right Side Rail (/E)
23	300217-19	1 (see note)	Right Side Rail (/F)
24	64024-402	1	Fuel Level Gauge
25	64024-401	1	Sealed Fuel Cap
26	80903-000	1	Slosh Valve (revision A)
26	80903-002	1	Slosh Valve with Grommet (revision B)
27	80903-001	1	Grommet (revision A)
28	64024-404	1	Shut-off Valve
NI	64024-403	1	Fuel Filter under Cap
NI	64024-406	4	Rubber Bushing
NI	64024-405	4	Anti-Crush Insert
NI	Not Illustrated		

Note: WC10000VE/F side rails must go with /F cradle assembly.

# BATTERY HOLD DOWN KIT

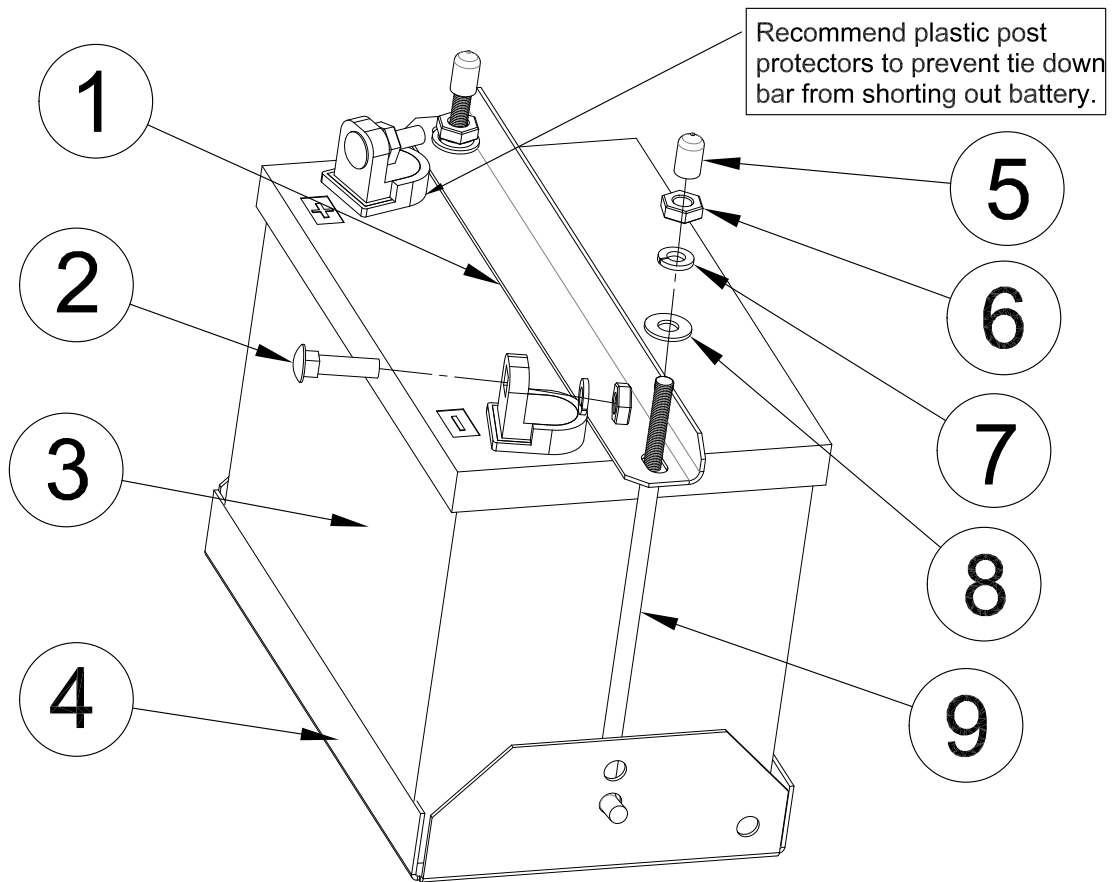

REF #	PART NUMBER	QTY	DESCRIPTION
1	64167-004	1	Hold Down Bracket
2	56842-001	2	Carriage Bolt
3	Battery	1*	BCI Group Size U1 Rated at 275 CCA
4	15676-006	1*	Battery Tray
5	64278-000	2	Vinyl Protective Cap
6	638-000	4	1/4" Hex Nut
7	479-000	4	1/4" Lock Washer
8	512-000	2	1/4" Flat Washer
9	64240-002	2	Hold Down Rod
*	Not part of this kit		



# GENERATOR END

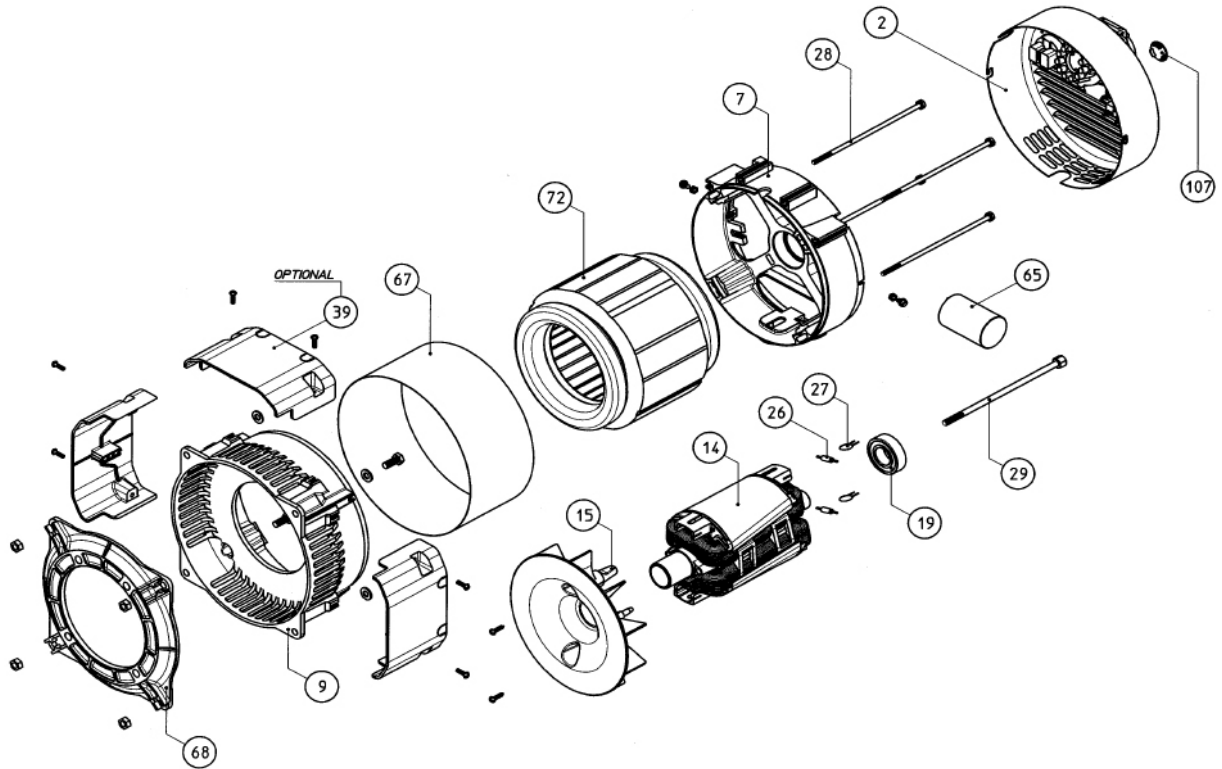

REF #	PART NUMBER	QTY	DESCRIPTION
	16346-004	1	Complete Generator End
19	54665-000	1	6205-2RS Bearing
26	300323-208	2	Varistor
27	300323-207	2	Diode
65	Reference	1	Capacitor (re-located to receptacle panel assembly)

## GENERATOR SPECIFICATIONS:

STATOR:	0.145 Ohms
ROTOR:	5.67 Ohms
CAPACITOR LEADS	1.31 Ohms

# LIFTING EYE

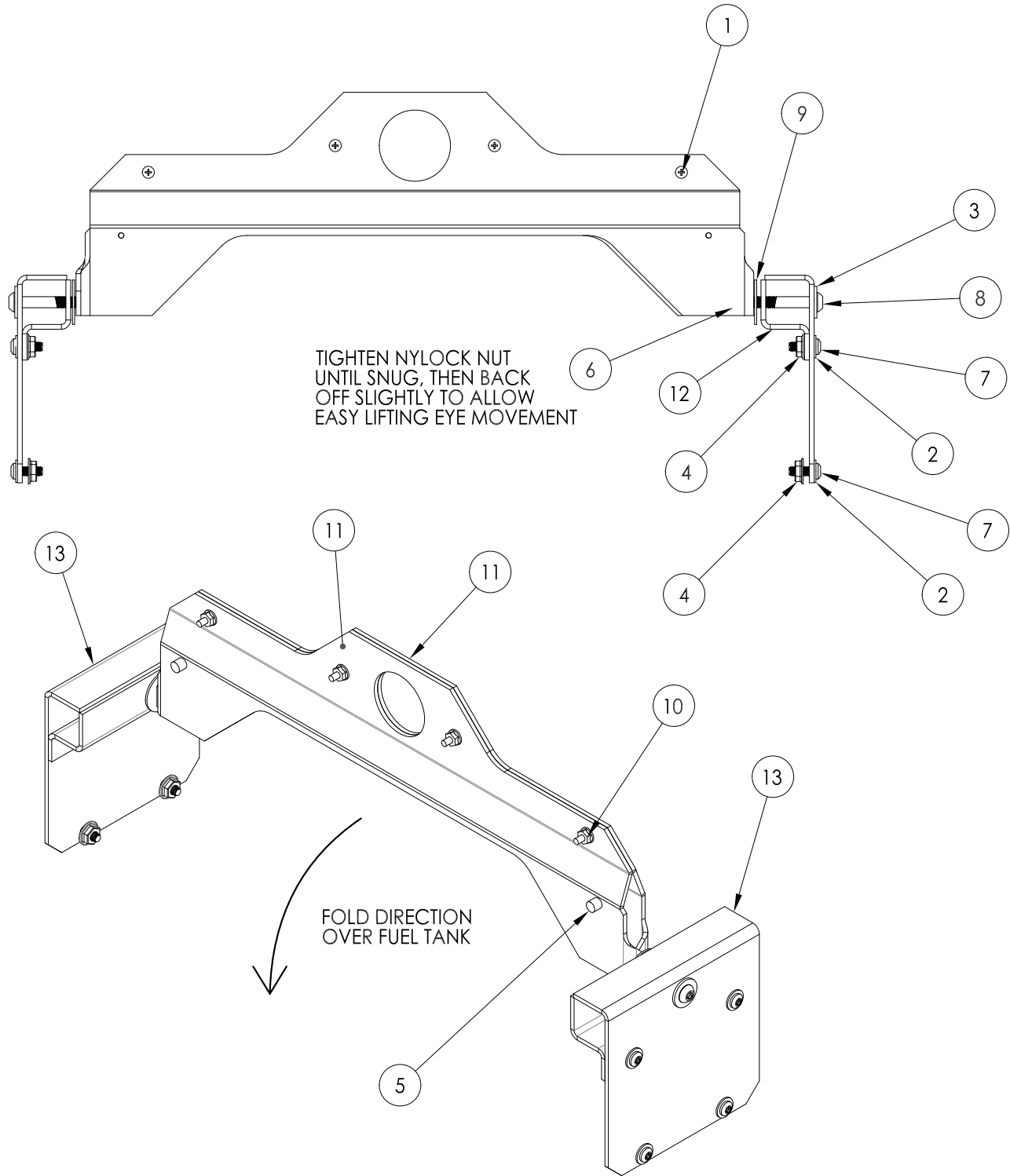

REF #	PART NUMBER	QTY	DESCRIPTION
1	420-001	4	10-24 X 3/4" Phillips Screw
2	512-000	8	1/4" Washer
3	526-000	2	3/8" i.d. 7/8" o.d. Washer
4	16248-000	8	1/4" – 20 Flange Nut
5	20952-001	2	Rubber Bumper
6	47136-000	2	5/16" – 18 Nylok Hex Nut
7	64858-001	8	1/4" – 20 X 3/4" Bolt
8	64858-006	2	5/16" – 18 X 2.25" Bolt
9	96286-006	2	Flat Nylon Washer
10	99671-000	4	# 10 – 24 Hex Nut
11	300148-7	2	Lifting Eye
12	300148-10	2	Inside Bracket
13	300149-9	2	Lifting Eye Support

## DOLLY KIT

REF #	PART NUMBER	QTY	DESCRIPTION
1	15775-019	2	Axle Bracket
3	16205-004	1	Foot
4	16343-000	2	Shaft Protector
5	43657-008	2	Hard Rubber Wheel
6	61857-008	1	Handle
7	64326-024	1	Axle 3/4" X 28"
9	300066-14	1	Left Handle Support
10	300066-15	1	Right Handle Support
11	466-000	2	1/4" – 20 X 3/4" Bolt
12	526-000	6	3/8" id .890 od Washer
13	1178-000	2	Flat Washer
14	16248-000	2	1/4" – 20 Flange Nut
15	16249-000	6	5/16" – 18 Flange Nut
16	20191-000	2	Shock Mount
17	47517-000	2	1/4" – 20 Nylok Nut
18	56842-005	2	1/4" – 20 X 2" Bolt
19	64327-000	2	Hub Cap
20	64688-006	2	Axle Spacer
21	91245-000	4	5/16" – 18 X 5" Bolt
22	91672-011	2	5/16 – 18 X 4" Bolt
23	93402-002	2	Hole Plug
24	96286-006	2	Flat Nylon Washer

# DOLLY KIT

