

#### WIRING DIAGRAM

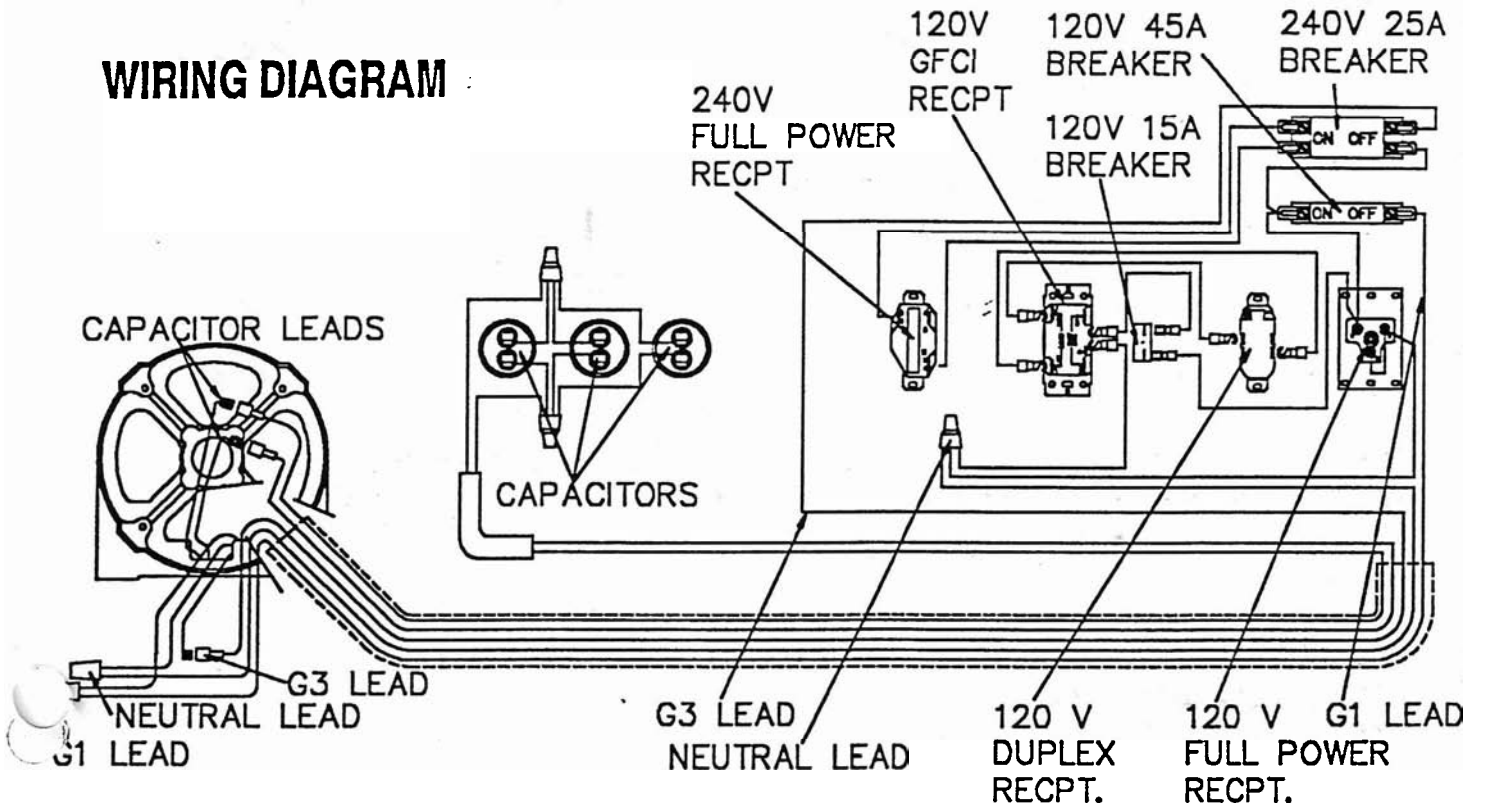

#### GENERATOR SCHEMATIC

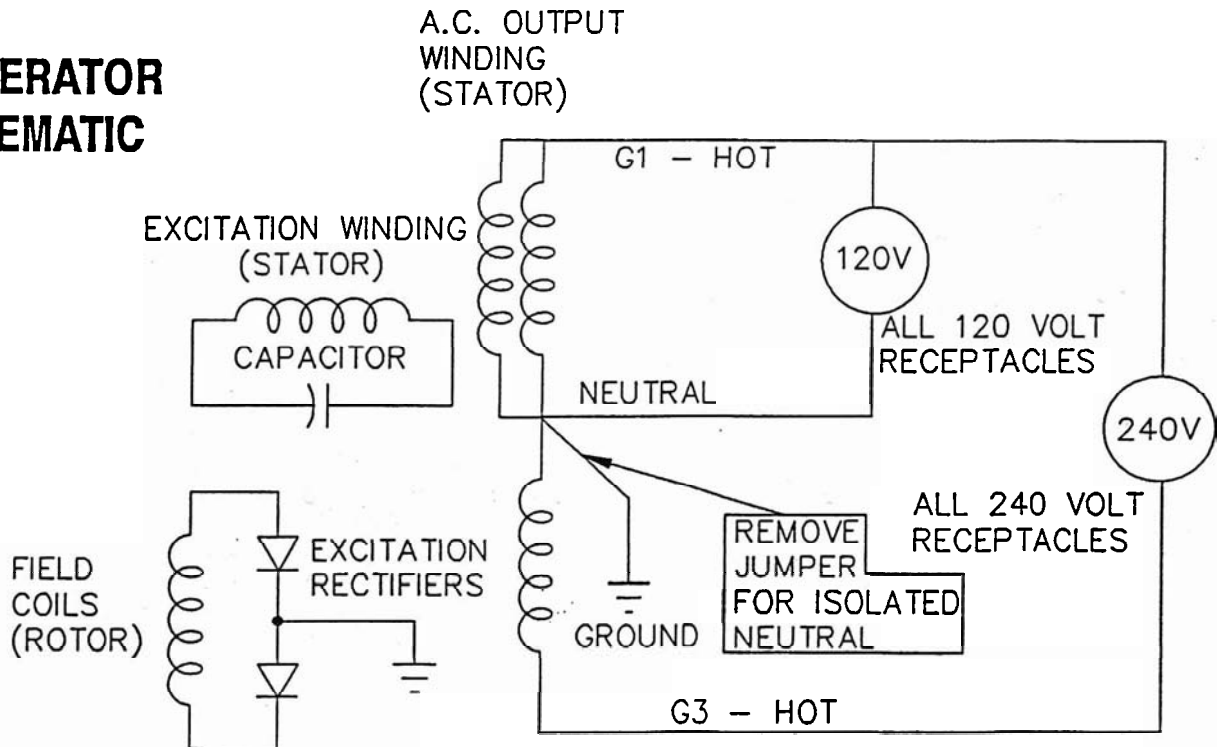

# COMPLETE UNIT ASSEMBLY

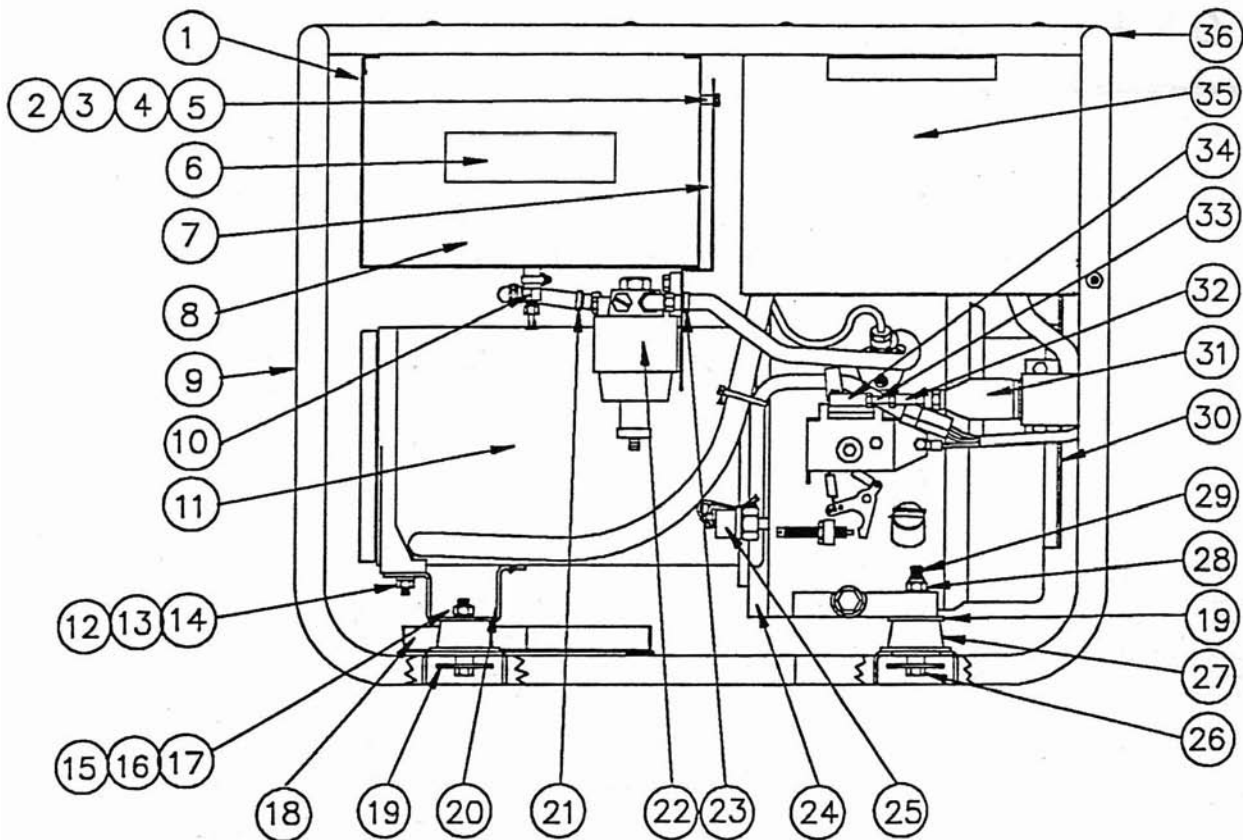

REF	PART #	QTY	DESCRIPTION
1	15851-000	1	Tank Support
2	62825-002	3	Spacer
3	484-000	3	Lockwasher #10
4	456-000	3	Hex Nut #10-24
5	420-000	3	Machine Screw #10-24 X 3/4
6	15209-000	1	Warning Decals
7	15855-000	1	Heat Shield
8	15852-000	1	Tank Cover
9	15778-000	1	Cradle
10	98771-000	1	Petcock
11	N/A		Generator Assembly
12	580-000	2	Cap Screw 5/16-18 x 1 1/4
13	480-000	2	Lockwasher 5/16
14	458-000	2	Hex Nut 5/16-18
15	91658-000	1	Cap Screw 3/8-16 X 2 1/2
16	481-000	1	Lockwasher 3/8
17	459-000	1	Hex Nut 3/8-16
18	15789-000	1	Battery Tray
19	98806-000	5	Safety Washer
20	15084-000	1	Generator Support
21	40078-000	1	Hose 5.75"

REF	PART #	QTY	DESCRIPTION
22	97303-000	1	Fuel Filter
23	72300-000	2	Hose Fitting
24	N/A		Yanmar L100AE-DEG
25	99036-000	1	Oil Pressure Switch
26	91658-014	2	Cap Screw 3/8-16 X 3 1/2
27	98807-000	3	Shockmount
28	526-000	2	Flatwasher 3/8
29	56864-000	2	Locknut 3/8-16
30	15786-000	1	Blower Guard
31	99008-003	1	Solenoid
32	99035-000	1	In Line Swivel
33	91925-003	1	Threaded Rod 1/4-28 X 2
34	63650-000	1	Ball Joint
35	15847-000	1	Control Panel
36	97382-000	1	Decal Warning
NI	15063-003	1	Battery Cable POS
NI	15067-003	1	Battery Cable NEG
NI	15807-000	1	Battery Hold Down Kit

\* NI - Not Illustrated

# FUEL TANK ASSEMBLY

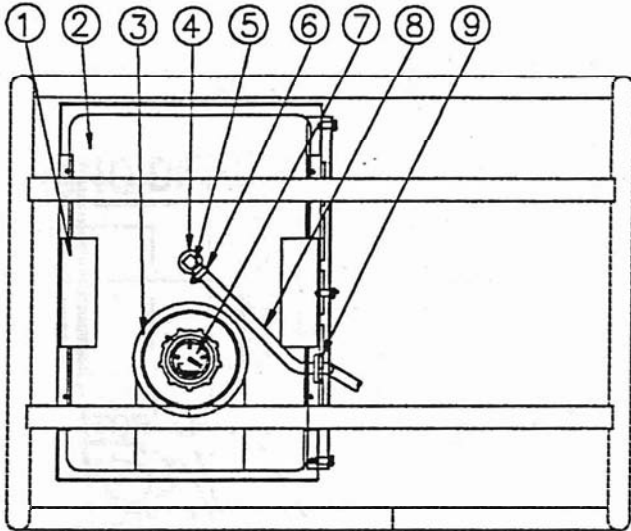

REF	PART #	QTY	DESCRIPTION
1	15854-000	2	Tank Holddown
2	64024-001	1	Fuel Tank
3	58684-000	1	Edge Trim 14.5"
4	62409-000	1	Bushing
5	98435-000	1	Elbow
6	81018-009	2	Clamp
396-3 →	<del>98729-001</del>	1	Fuel Cap
8	40078-000	1	Fuel Line 22.75"
9	23917-000	1	Grommet

# CONTROL BOX ASSEMBLY

## BACK PANEL

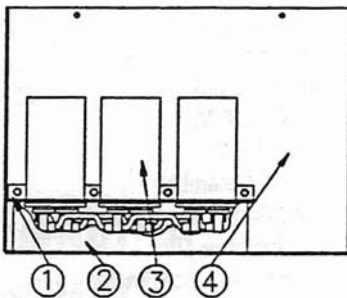

REF.	PART #	QTY	DESCRIPTION
1	15167-000	1	Foam 8"
2	15051-000	3	Capacitor
3	15226-000	1	Capacitor Clamp
4	15846-000	1	Back Panel

## FRONT PANEL

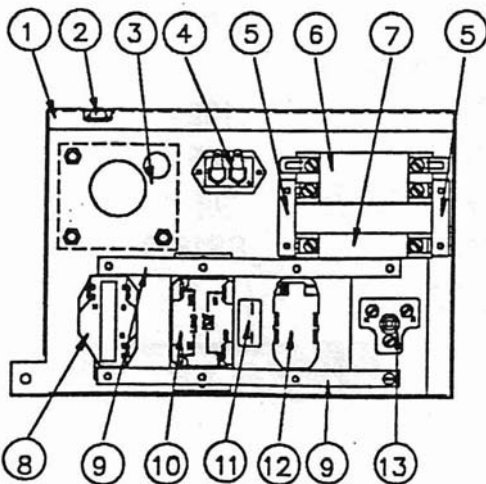

REF	PART #	QTY	DESCRIPTION
1	15845-000	1	Control Panel
2	92495-000	4	Nut Retainer
3	15806-010	1	Yanmar Harness
4	58166-006	1	Running Time Meter
5	64045-000	2	Ground Strap
6	57030-009	1	Circuit Breaker, 240 Volt 25 Amp
7	91977-006	1	Circuit Breaker, 120 Volt 45 Amp
8	57324-000	1	Receptacle, NEMA I6-30R
9	64045-001	2	Ground Strap
10	15147-002	1	GFCI Receptacle, NEMA 5-15R
11	91286-000	1	Circuit Breaker 120 Volt 15 Amp
12	24749-000	1	Receptacle, NEMA 5-15R
13	54545-000	1	Receptacle, NEMA 5-50R

# GENERATOR ASSEMBLY

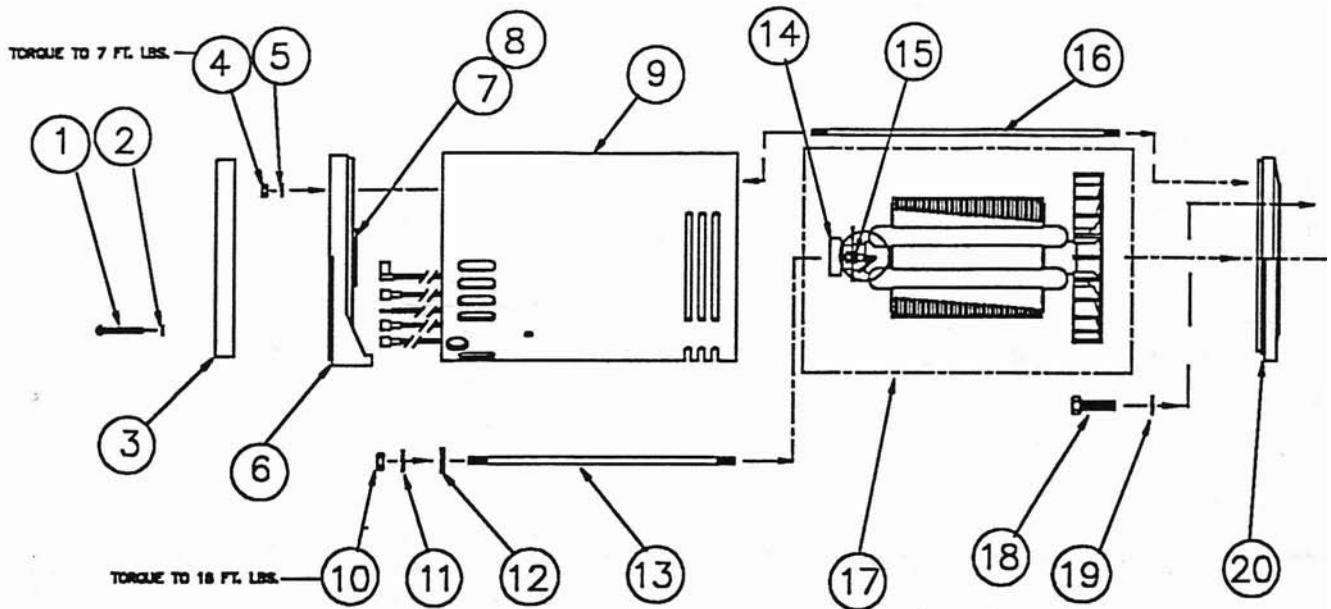

REF	PART #	QTY	DESCRIPTION
1	15013-001	4	Machine Screw #10-32 X 1.75
2	21975-000	4	Lockwasher #10
3	15085-000	1	End Cover
4	15192-000	4	Hex Nut 1/4-20
5	479-000	4	Lockwasher 1/4
6	15156-003	1	End Bracket
7	15688-000	1	Shim
8	15122-000	3	Tolerance Ring
9	15091-011	1	Stator Assembly
10	15193-000	1	Hex Nut 5/16-24
11	480-001	1	Lockwasher 5/16

REF	PART #	QTY	DESCRIPTION
12	23558-000	1	Flat Washer 5/16
13	23197-016	4	Stud 5/16-24
14	50215-000	1	Bearing
15	15047-001	1	Diode (STD)
	15047-002	1	Diode (REV)
16	15068-009	4	Stud 1/4-20
17	15045-011	1	Rotor Assembly
18	96002-040	4	Cap Screw M8-1.25 X 40MM
19	97436-008	4	Lockwasher M8
20	15008-000	1	Engine Adapter Bracket

## TECHNICAL DATA

### Generator Output

Surge Watts	6000
Continuous Watts	5500
Amperage Rating	
120V	45.8
240V	22.9
Motor Starting Ability	3 HP
Engine RPM	3600

### Generator Resistance

Rotor	2.0
Stator Leads	
G1-N	.132
G3-N	.265
Capacitor Leads	.365
Winding Spec.	SS1533

**WINGO**®

INCORPORATED  
225 South Cordova  
Le Center, MN 56057  
1-612-357-6831