

	DX2000/L, DP3000/M, DX3200/L, DX3200H/L	KAW 2000	B&S 3000	KAW 3200	HONDA 3200		
1	100	ENGINE - KAW -	15187-000	1	--	--	1
2		ENGINE - B&S130232-5502	15189-000	--	1	--	2
3		ENGINE - KAW -	63955-000	--	--	1	3
4		ENGINE - HONDA GX140 -	15250-000	--	--	--	4
5	198	SPARK ARRESTER (ON MUFLR)	58596-000	--	1	--	5
6	199	EXHAUST DFLCTR (ON MUFLR)	58935-000	--	1	--	6
7							7
8	248	RECEPT. - 120V 5-15R	24749-001	2	2	2	8
9	258	CIRCUIT BREAKER - 15A	64230-000	1	2	2	9
10							10
11	280	CAPACITOR (40mfd/370V)	15051-000	1	1	1	11
12	290	END COVER ASSY W/RECEP	15119-000	1	--	--	12
13		END COVER ASSY W/RECEP	15087-000	--	1	1	13
14	291	END COVER (BARE)	15133-000	1	--	--	14
15		END COVER (BARE)	15050-000	--	1	1	15
16							16
17	502	THRU-BOLT	15011-006	1	1	1	17
18	511	END BRACKET - ENG END	15053-001	1	1	1	18
19	512	END BRACKET - BRG END	15015-001	1	1	1	19
20							20
21	514	STATOR ASSEMBLY	15093-000	1	1	1	21
22	530	ROTOR ASSY W/BRG & FAN	15045-003	1	1	1	22
23	532	BEARING	55223-000	1	1	1	23
24							24
25	601	CRADLE	15072-000	1	1	1	25
26	602	ENGINE SUPPORT BAR	62832-000	1	1	1	26
27	603	SHOCK MOUNT	71605-003	4	4	4	27
28							28
29	901	DECAL SET - SAFETY	15209-000	1	1	1	29
30	902	DECAL - DX2000	64214-024	1	--	--	30
31		DECAL - DP3000	64214-029	--	1	--	31
32		DECAL - DX3200	64214-025	--	--	1	32
33							33
34	906	NAMEPLATE	63966-000	1	1	1	34
35	998	OPERATORS MANUAL	60706-077	1	1	1	35
36							36
37	500	GEN. ASSY. - COMPLETE	15041-002	1	--	--	37
38		GEN. ASSY. - COMPLETE	15041-003	--	1	1	38
39							39
40							40

DX2000/L, DP3000/M, DX3200/L, DX3200H/L		KAW	B&S	KAW	HONDA	
		2000	3000	3200	3200	
41	000	COMPLETE UNIT ASMBLY.	15180-002	#	--	41
42		COMPLETE UNIT ASMBLY.	15180-001	--	#	42
43		COMPLETE UNIT ASMBLY.	15180-003	--	#	43
44		COMPLETE UNIT ASMBLY.	15180-009	--	#	44
45						45
46						46
47						47
48						48
49						49
50		FOLLOWING INFORMATION IS FOR REFERENCE ONLY				50
51	535	FAN	15136-001	1	1	51
52	566	RECTIFIER - STD POLARITY	15047-001	1	1	52
53	567	RECTIFIER - REV POLARITY	15047-002	*	*	53

* - OPTIONAL - INSTALLED ON EARLY MODELS ONLY

UNIT MODEL SERIES	DX2000	DP3/DX3200
AC RESIDUAL VOLTS	7.0 VAC L-L	7.0 VAC L-L
FIELD RESISTANCE	1.9 OHMS	1.9 OHMS
SCHEMATIC DIAGRAM	B-15135	B-15135
WINDING SPEC (SS#)	1530	1530
ARM CONNECTION (AC#)	369	369

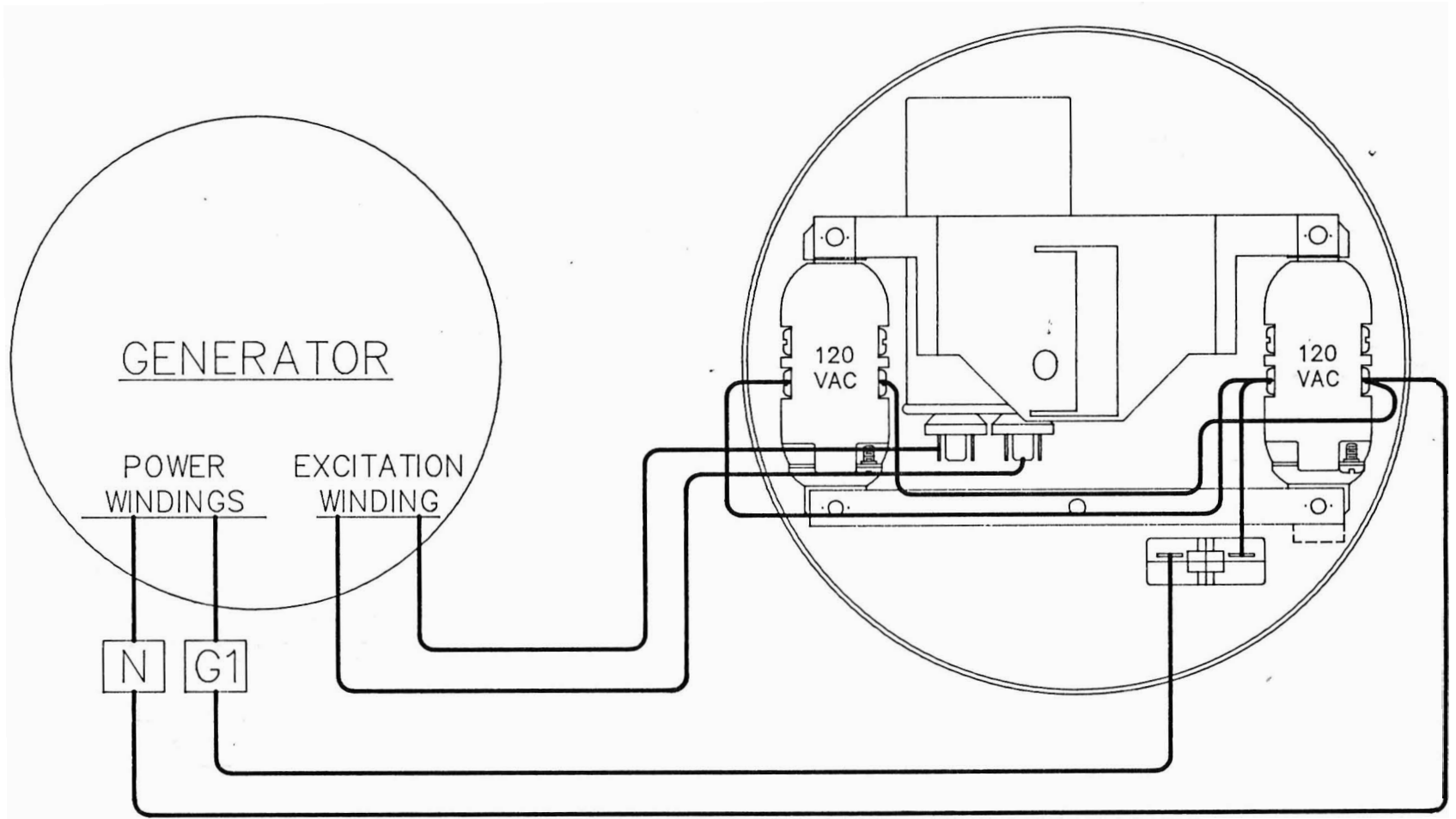

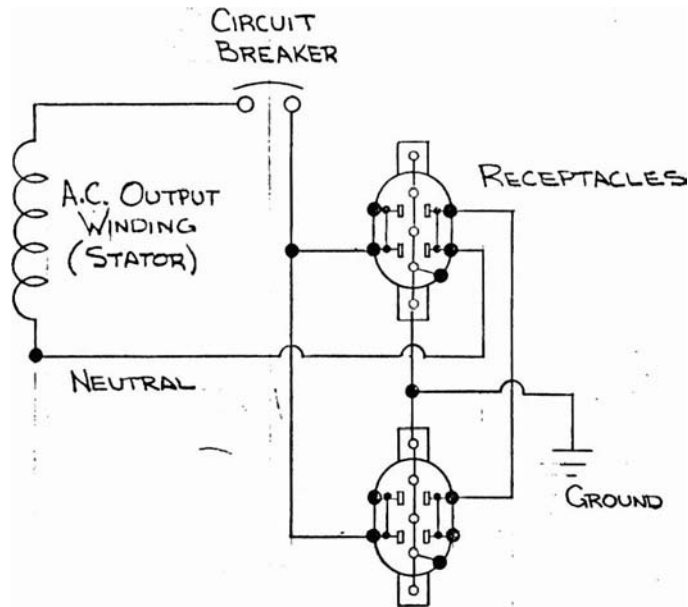
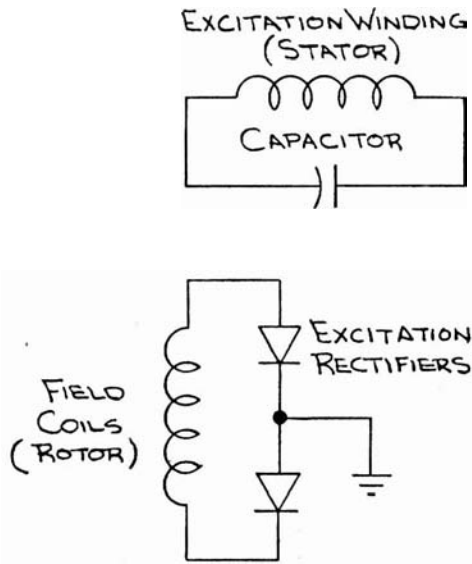

NOTE:
MODEL DP2000

REF: B-15119

ITEM	PART NO.	QUAN.	DESCRIPTION
UNLESS OTHERWISE SPECIFIED:			MACHINED SURFACE TEXTURE
FRACTIONS ±		ANGULAR	ALL DIMENSIONS GIVEN IN INCHES WORK TO DIMENSIONS - DO NOT SCALE -
1. PLACE DEC. ±		±	
2. PLACE DEC. ±			
3. PLACE DEC. ±			
DRAWN BY INDBLOW		DATE 1-30-89	CHECKED BY DR
		DATE 2/2/77	APPROVED BY L.H.
		DATE 2/1/77	SCALE 1:1
THIS DRAWING CONTAINS PROPRIETARY INFORMATION BELONGING TO ENERGY UNAUTHORIZED USE IS PROHIBITED.			
MATERIAL		TITLE: SCHEMATIC	
FINISH		MODEL 15041	
MODEL		SEE NOTE	
ENERGY CORPORATION			PART NO. B-15134