

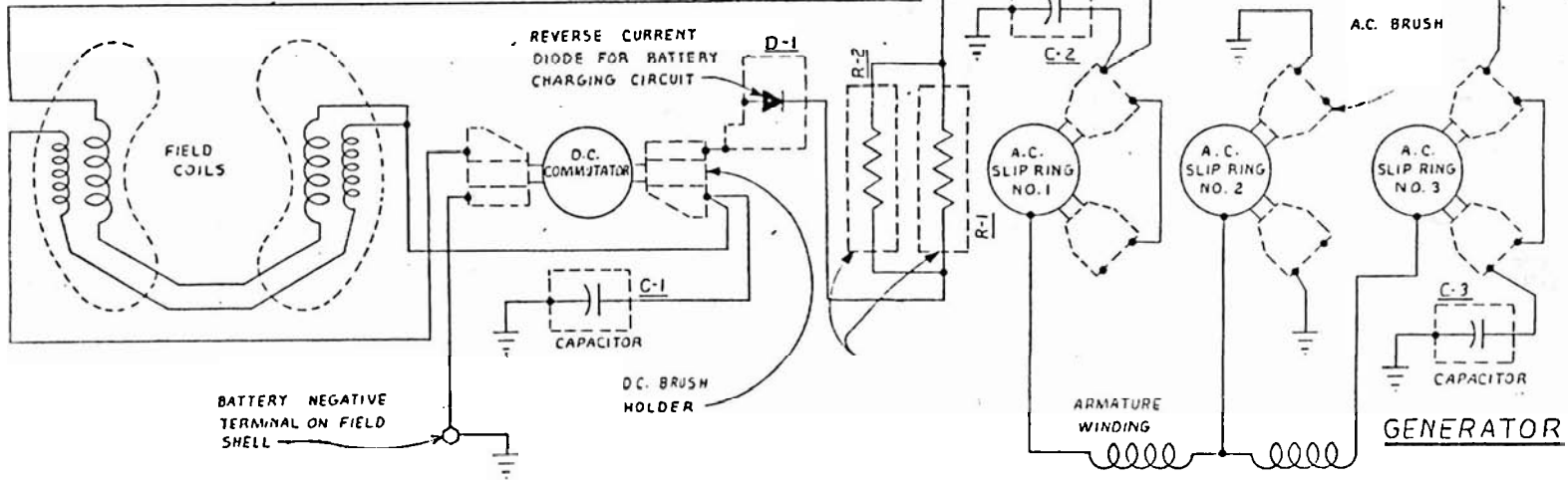

TO RECEPTACLES,

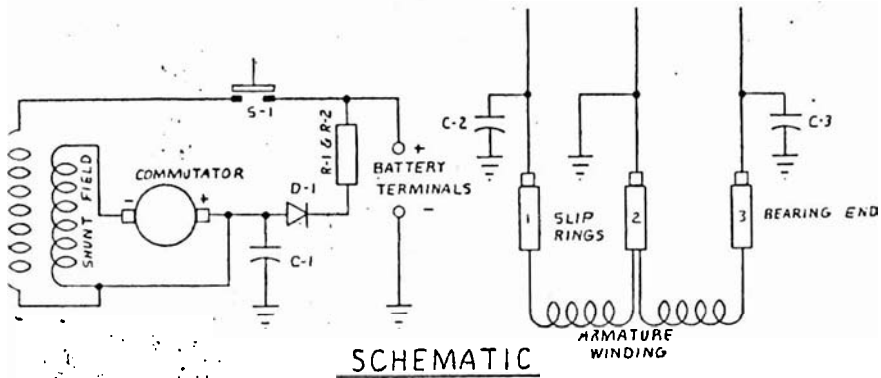

54136

battery and charge circuit

excitation circuit

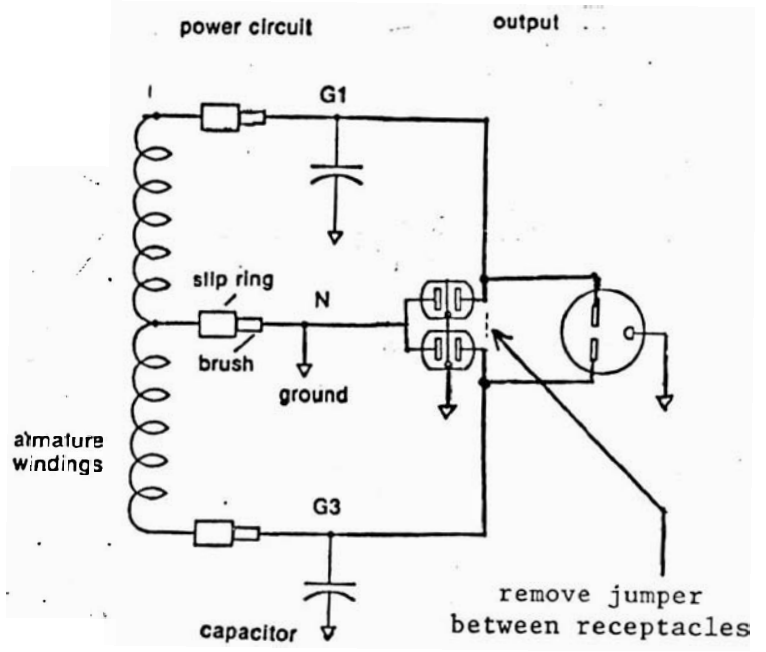
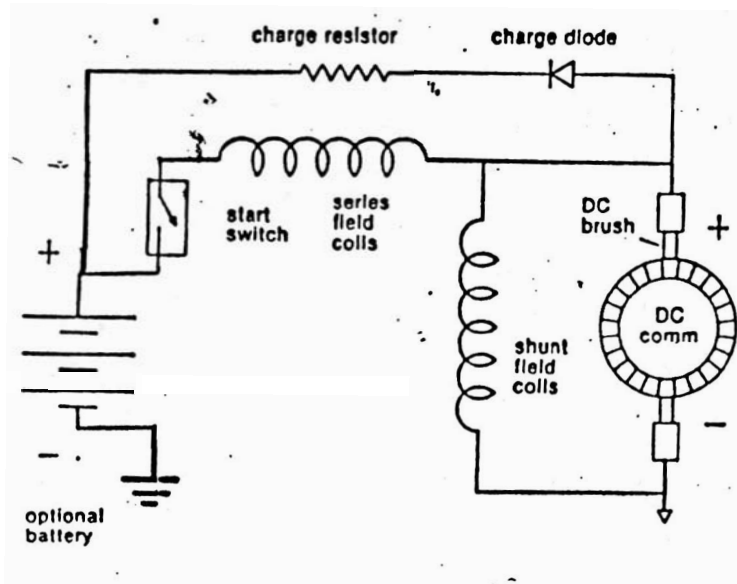

SCHEMATIC WIRING DIAGRAM