

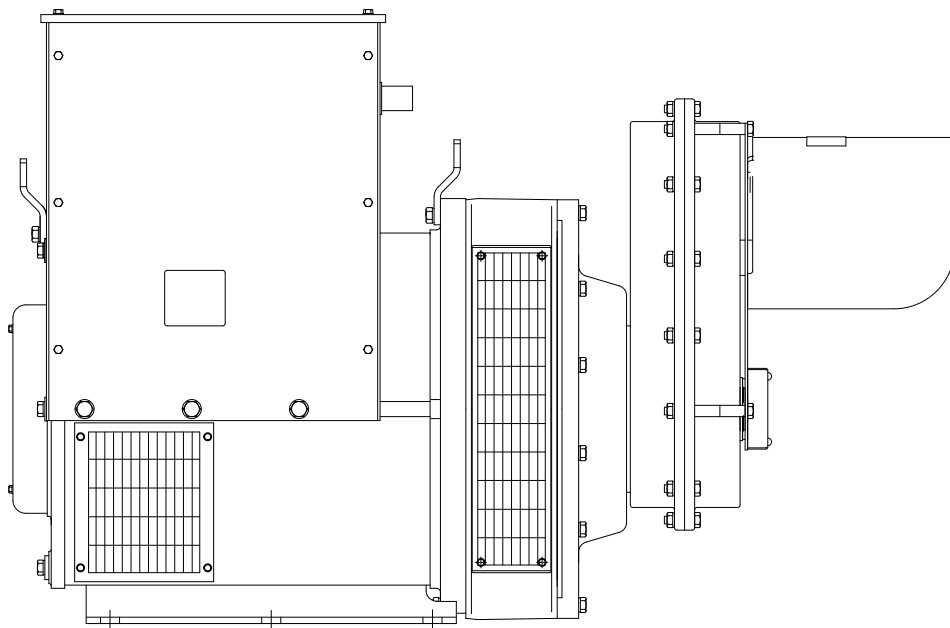

ILLUSTRATED PARTS LIST

W120FPTOT-18/C



WINCO INC.
225 S. CORDOVA AVE.
LE CENTER, MN 56057
(507) 357-6821
SERVICE DEPT.
(507) 357-6831
wincogen.com

COMPLETE ASSEMBLY

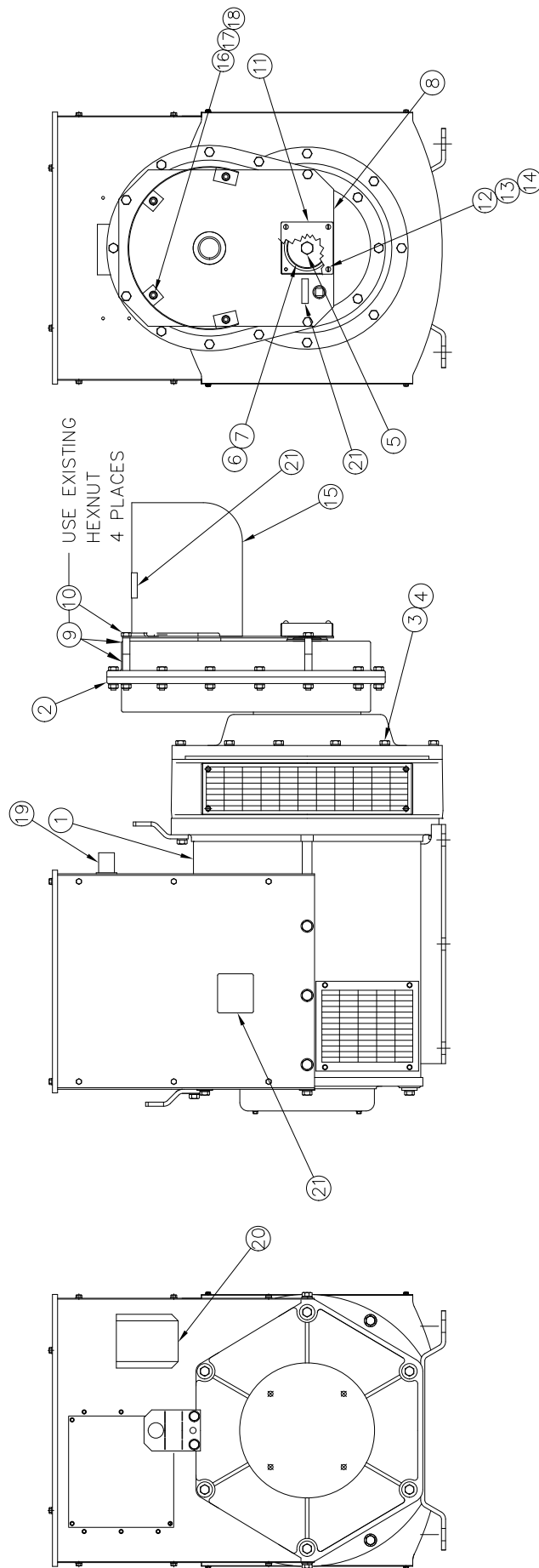

29	AVR SX460	1	DECAL – SX460 AVR
28	6372-000	4	NUT
27	A-64914-000	16	M6 RETAINER NUT
26	1744-000	4	1/2-13 HEXNUT (SHIPPING)
25	21867-000	4	1/2 FLATWASHER (SHIPPING)
24	A-61603-005	4	1/2-13 X 2-1/2 CARRIAGE BOLT (SHIPPING)
23	A-BP-10099-1	1	PLUG KIT (SHIPPED LOOSE)
22	60706-160	1	OPERATOR'S MANUAL
21	B-64894-007	1	DECAL AND NAMEPLATE INSTALLATION
20	B-300113-11	1	RECEPTACLE PANEL ASSEMBLY
19	300101-19	1	MAIN LINE BREAKER PANEL ASSEMBLY
18	A-16249-000	4	5/16-18 HEX FLANGENUT
17	526-000	4	5/16 FLAT WASHER
16	465-000	4	5/16-18 X 7/8 HEX HEAD BOLT
15	S-7606	1	PTO SHAFT GUARD
14	484-000	4	# 10 SPLIT LOCKWASHER
13	456-000	4	#10-24 HEX NUT
12	A-52464-002	4	#10-32 X 1-1/2 ROUND HEAD SCREW
11	A-300105	1	LOWER SHAFT GUARD
10	A-91658-015	4	3/8-16 X 4 HEX HEAD BOLT
9	A-62825-004	8	SPACER
8	A-300104	1	PTO SHAFT GUARD SUPPORT PLATE
7	A-300096	1	SHAFT WASHER
6	A-300106-1	1	BELLEVILLE WASHER, 5/8"
5	A-350096-35	1	M16-2.00 X 35MM HEX HEAD BOLT
4	A-97436-010	12	M10 SPLIT LOCKWASHER
3	A-96003-040	12	M10 X 1.50 X 35 MM HEX HEAD BOLT
2	B-300100-2	1	GEARCASE
1	B-351811-2	1	GENERATOR
ITEM	PART NO	QTY	DESCRIPTION

REF #	PART NUMBER	QTY	DESCRIPTION
NI	350818	1	SX460 Voltage Regulator
NI	Not Illustrated		

**STAMFORD NEWAGE GENERATOR
INFORMATION:**

MODEL: UCI274F2L TWO BEARING

<https://www.cumminsgeneratortechnologies.com/en/>

CIRCUIT BREAKER PANEL ASSEMBLY

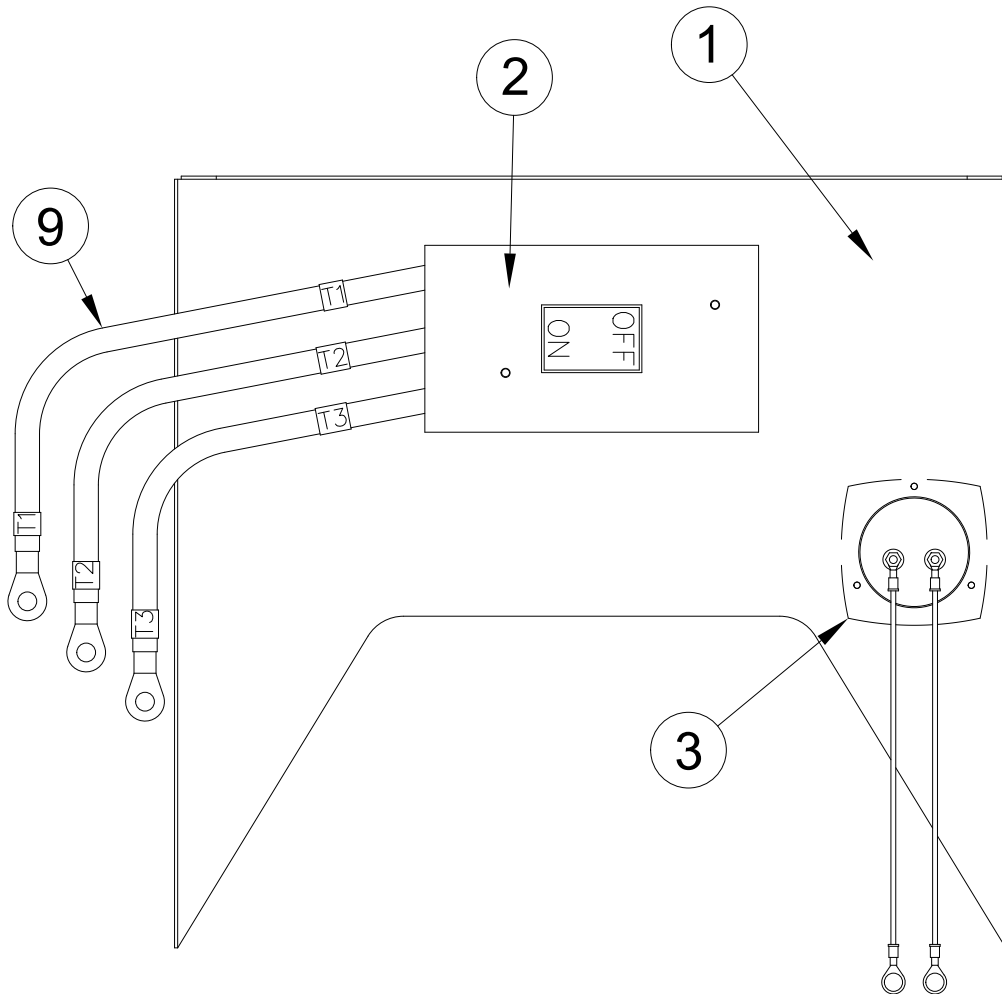

15	A-24862-012	2	LEAD I.D. TAPE (T3)
14	A-24862-011	2	LEAD I.D. TAPE (T2)
13	A-24862-010	2	LEAD I.D. TAPE (T1)
12	A-91457-002	2	TERMINAL LUG
11	A-12624-000	3.7FT	LEAD WIRE (16 GA.)
10	A-4160-000	2	TERMINAL LUG
9	B-91450-000	9.83FT	LEAD WIRE (#1 AWG)
8	A-91321-000	3	TERMINAL LUG
7	598-000	2	FW #10
6	484-000	2	SLW #10
5	6372-000	2	HN 10-32
4	24864-000	2	RHMS 10-32 x 4 1/2
3	A-300102	1	FREQUENCY METER
2	81097-044	1	175 A, 3 POLE, 600 V CIRCUIT BREAKER
1	350098-8	1	PANEL, MLB
ITEM	PART NO	QUAN.	DESCRIPTION

DECAL INSTALLATION

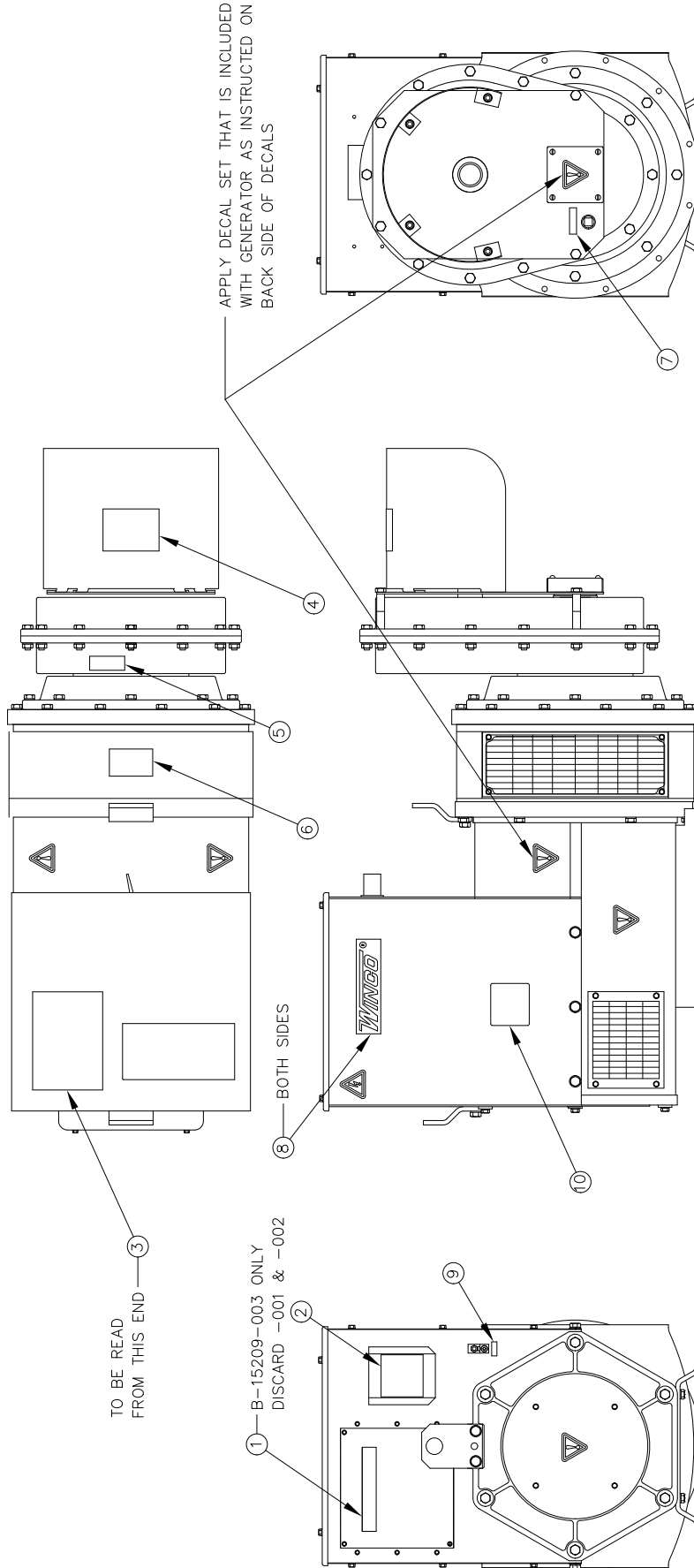

ITEM	PART NO	QUAN.	DESCRIPTION
11	AVR SX460	1	DECAL, AVR SX460
10	A-63966-007	1	NAMEPLATE KIT
9	A-15750-001	1	GROUND DECAL
8	A-53113-000	2	WINCO DECAL
7	A-16303-000	1	DECAL, OIL LEVEL
6	A-91369-001	1	DECAL, 1000 RPM
5	Z-9941	1	DECAL, OIL FILL
4	Z-2568	1	DECAL-DANGER PTO
3	Z-2553	1	DECAL, OPERATING INSTRUCTIONS
2	Z-2527-3	1	DECAL, ANDERSON THREE PHASE
1	B-15209-000	1	DECAL SET

WIRING DIAGRAM

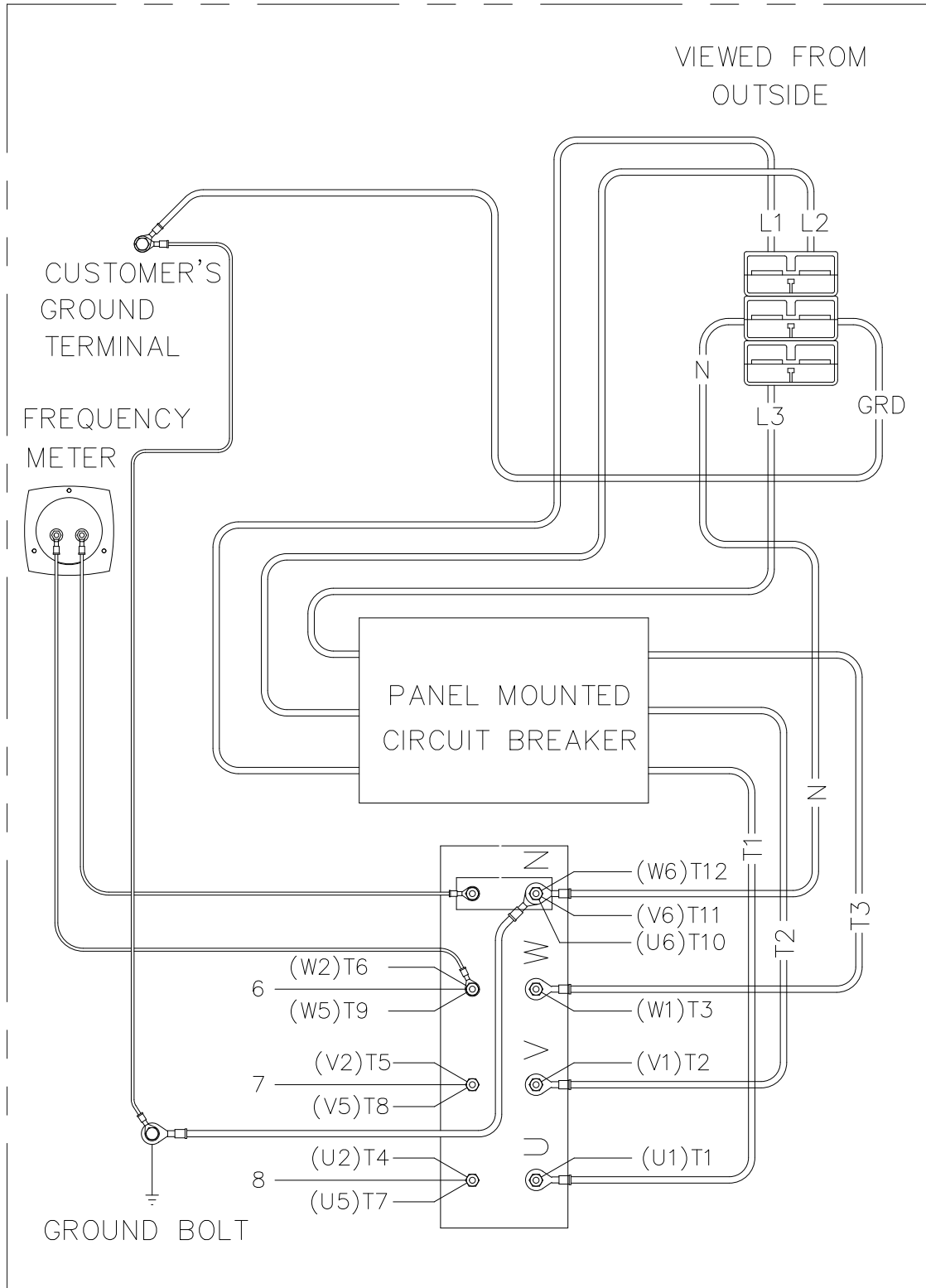

WIRING DIAGRAM (THREE PHASE WYE "12 WIRE"; 277/480)