

**ILLUSTRATED
PARTS LIST**

W150FPTOS/B

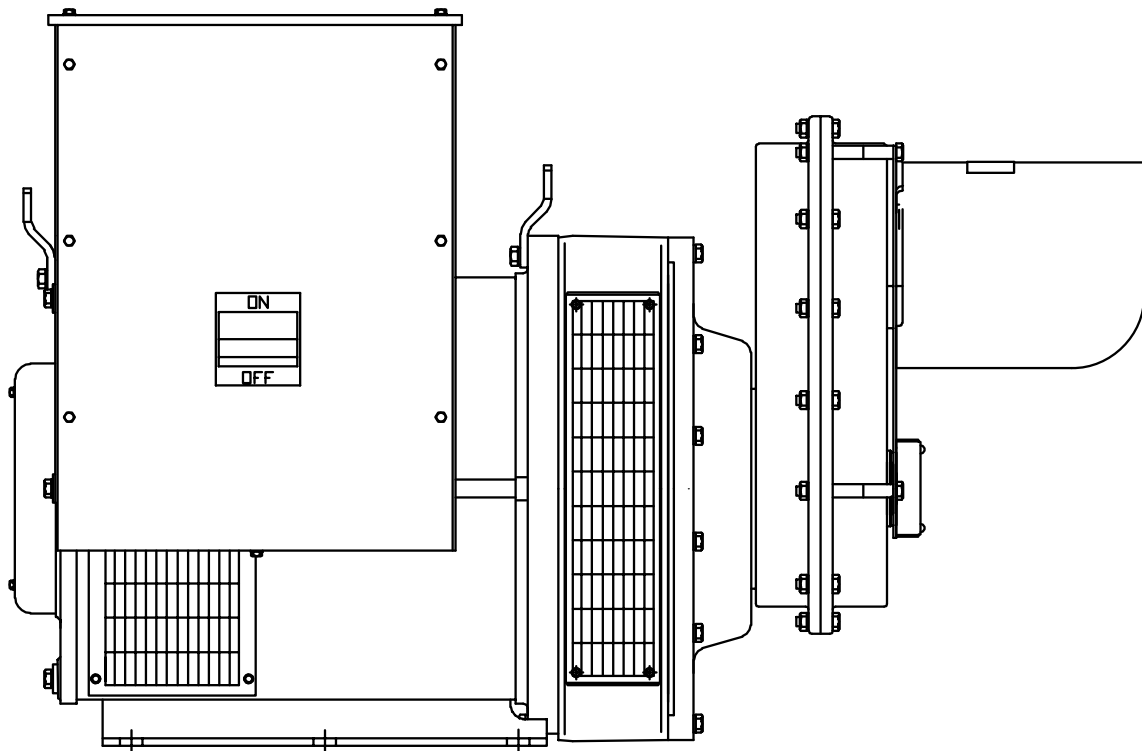

GENERATOR ASSEMBLY W150FPTOS/B

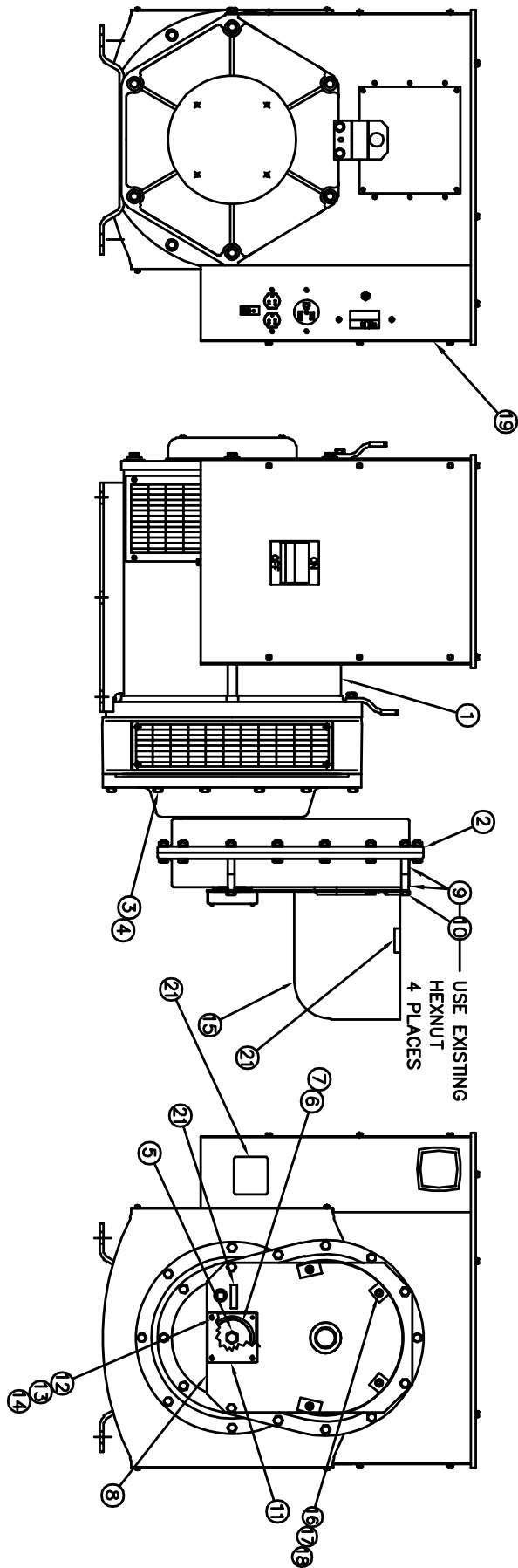

GENERATOR ASSEMBLY W150FPTOS/B

25	1744-000	4	1/2-13 HEXNUT (SHIPPING)
24	21867-000	4	1/2 FLATWASHER (SHIPPING)
23	A-61603-005	4	1/2-13 X 2-1/2 CARRIAGE BOLT (SHIPPING)
22	60708-124	1	OPERATOR'S MANUAL
21	B-64894-005	1	DECAL AND NAMEPLATE INSTALLATION
20	B-52118-041	1	LEAD WIRE ASSEMBLY
19	B-300173-10	1	MAIN LINE BREAKER PANEL INSTALLATION
18	A-16249-000	4	5/16-18 HEX FLANGENUT
17	526-000	4	5/16 FLAT WASHER
16	465-000	4	5/16-18 X 7/8 HEX HEAD BOLT
15	S-7606	1	PTO SHAFT GUARD
14	484-000	4	# 10 SPLIT LOCKWASHER
13	456-000	4	#10-24 HEX NUT
12	A-52464-002	4	#10-32 X 1-1/2 ROUND HEAD SCREW
11	A-300105	1	LOWER SHAFT GUARD
10	A-91658-015	4	3/8-16 X 4 HEX HEAD BOLT
9	A-62825-004	8	SPACER
8	A-300104	1	PTO SHAFT GUARD SUPPORT PLATE
7	A-300096	1	SHAFT WASHER
6	A-300106-1	1	BELLEVILLE WASHER, 5/8"
5	A-350096-50	1	M16-2.00 X 50MM HEX HEAD BOLT
4	A-97436-010	12	M10 LOCKWASHER
3	A-94282-035	12	M10 X 1.50 X 35 MM HEX HEAD BOLT
2	B-300100-2	1	GEARCASE
1	B-351811-41	1	GENERATOR
ITEM	PART NO	QUAN.	DESCRIPTION



225 S. CORDOVA AVE.
LECENTER, MN 56057
507-357-6821
SERVICE DEPT.
507-357-6831

STAMFORD NEWAGE GENERATOR
INFORMATION:

MODEL: UCI274F2J TWO BEARING

www.cumminsgeneratortechnologies.com

CIRCUIT BREAKER ASSEMBLY W150FPTOS/B

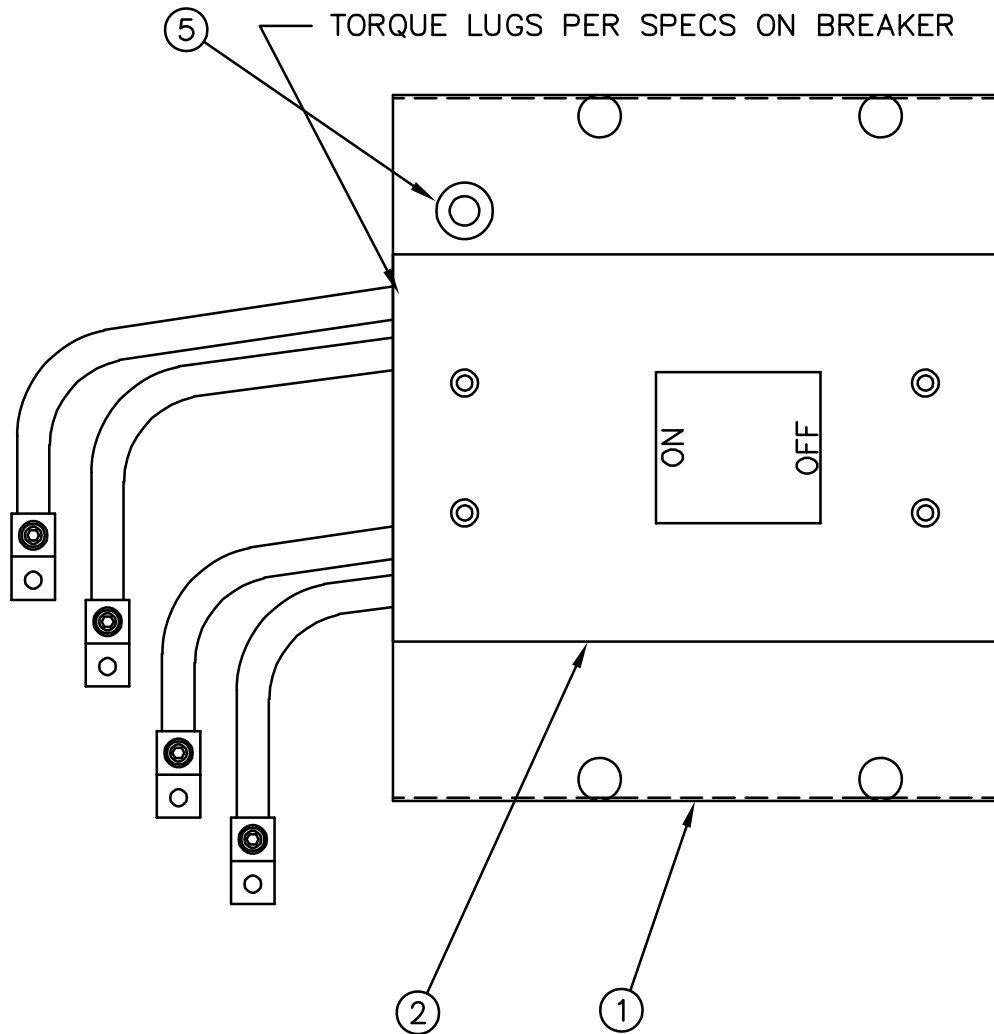

6	458-000	4	NUT
5	A-23917	1	GROMMET
4	A-300114	5.8FT	LEAD WIRE (3/0 AWG)
3	A-58060-001	4	TERMINAL LUG
2	A-350422-3	1	CB, 600 AMP, 2 POLE
1	A-300174	1	PANEL, MLB
ITEM	PART NO	QUAN.	DESCRIPTION

RECEPTACLE PANEL ASSEMBLY W150FPTOS/B

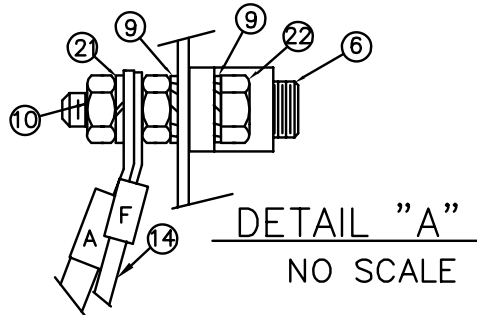
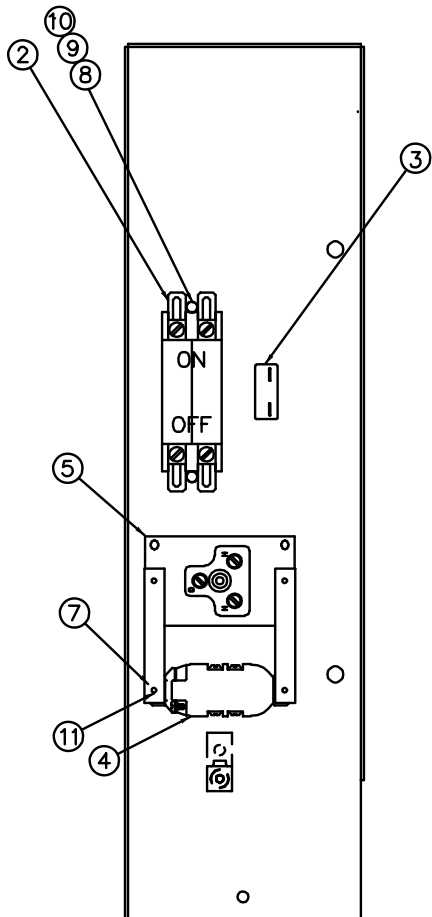

23	49975-010	2	TIE-WRAPS
22	439-000	1	HHCS 1/4-20 X 1
21	479-000	1	1/4 SPLIT LOCK WASHER
20	91320-002	2	LUG
19	91457-000	1	LUG
18	7547-000	1	LUG
17	4155-000	2	LUG
16	48602-001	2	LUG
15	21850-002	2	LUG
14	91780-000	6.92FT	LEAD WIRE 8 GA BLACK
13	91815-000	4.42FT	LEAD WIRE 14 GA BLACK
12	64638-000	3.5 FT	LEAD WIRE 10 GA GREEN
11	21698-001	4	# 10 SHEET METAL SCREW
10	638-000	4	HN 1/4-20
9	4516-000	4	1/4 EXTERNAL TOOTH LOCK WASHER
8	463-000	2	HHCS, 1/4-20 x 1/2
7	B-64045-002	2	STRIP, MOUNTING
6	A-63708	1	TERMINAL LUG
5	57325-000	1	RECEPTACLE, 50 AMP, 250 VOLT
4	A-50766-000	1	RECEPTACLE, 20A, 125 VOLT
3	A-91286-001	1	CB, 20 AMP, 1P
2	A-57030-000	1	CB, 50 AMP, 2P
1	B-300169-1	1	EXTENSION, LEFT TERMINAL BOX
ITEM	PART NO	QUAN.	DESCRIPTION

DECAL INSTALLATION W150FPOTS/B

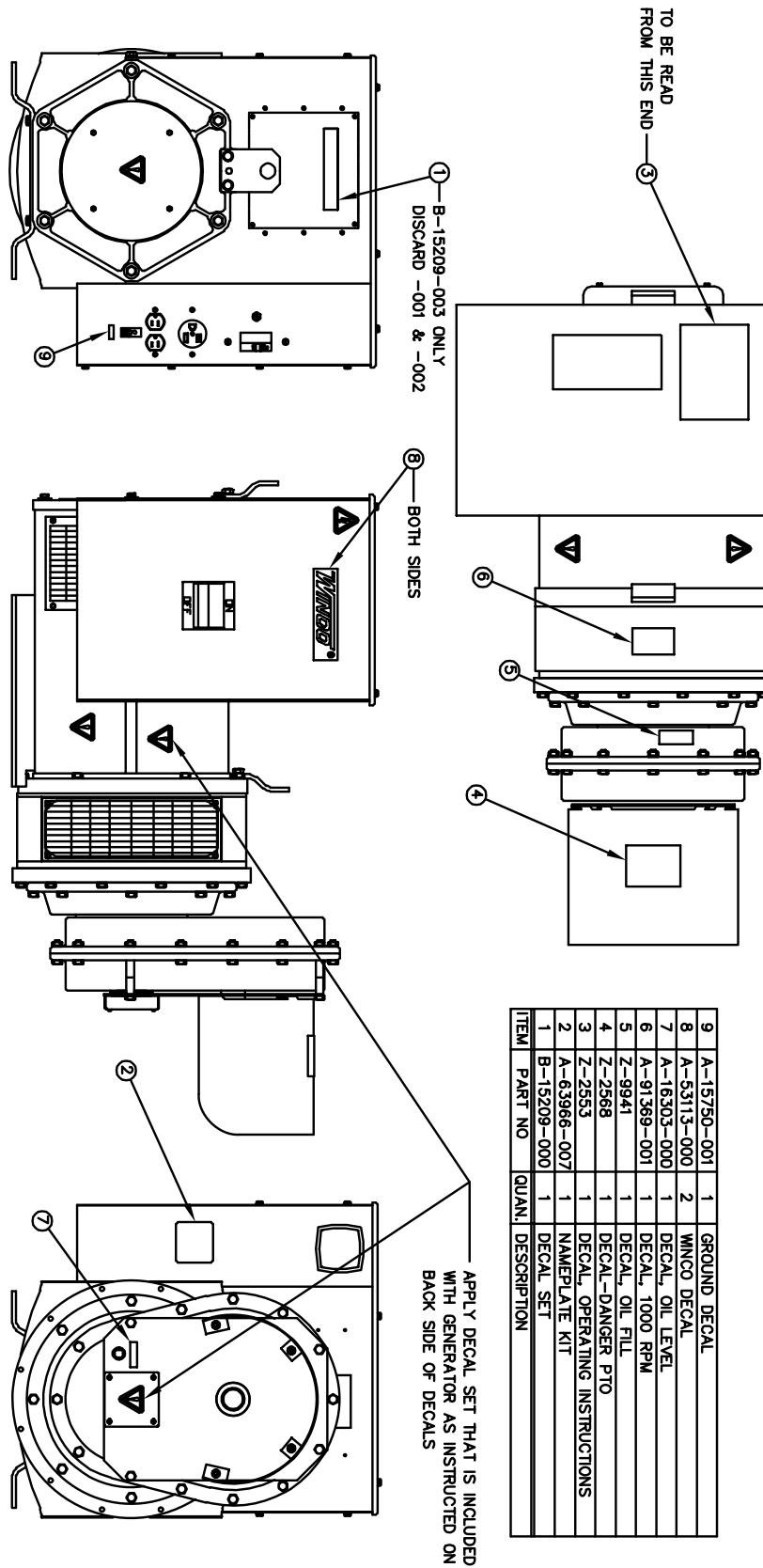

ITEM	PART NO	QUAN.	DESCRIPTION
9	A-15750-001	1	GROUND DECAL
8	A-53113-000	2	MINCO DECAL
7	A-16303-000	1	DECAL, OIL LEVEL
6	A-91369-001	1	DECAL, 1000 RPM
5	Z-9941	1	DECAL, OIL FILL
4	Z-2568	1	DECAL-DANGER PTO
3	Z-2553	1	DECAL-OPERATING INSTRUCTIONS
2	A-63966-007	1	NAMEPLATE KIT
1	B-15209-000	1	DECAL SET

WIRING DIAGRAM W150FPTOS/B

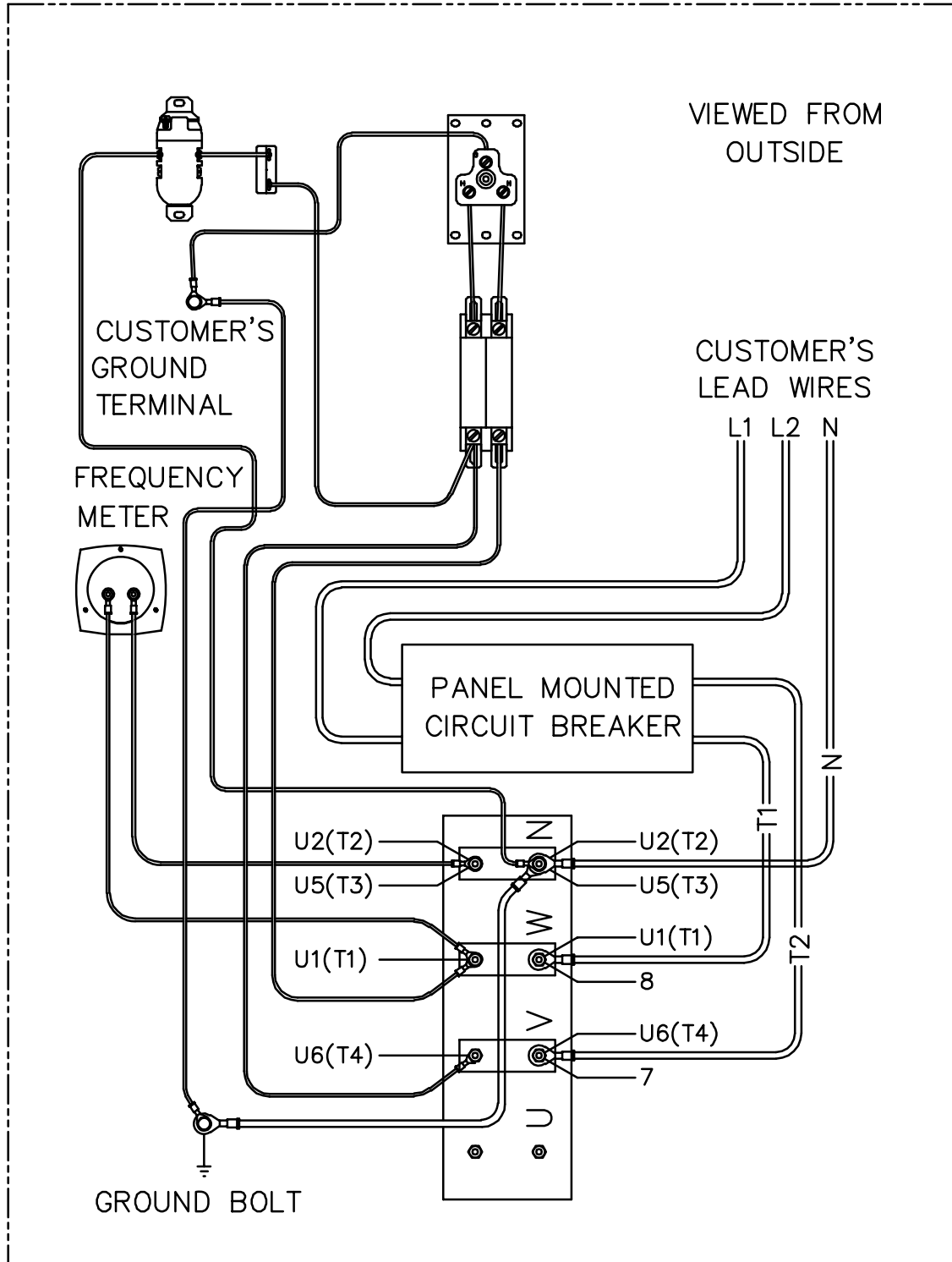

WIRING DIAGRAM (SINGLE PHASE "4 WIRE"; 120/240)