

### PARTS LIST & WIRING DIAGRAM

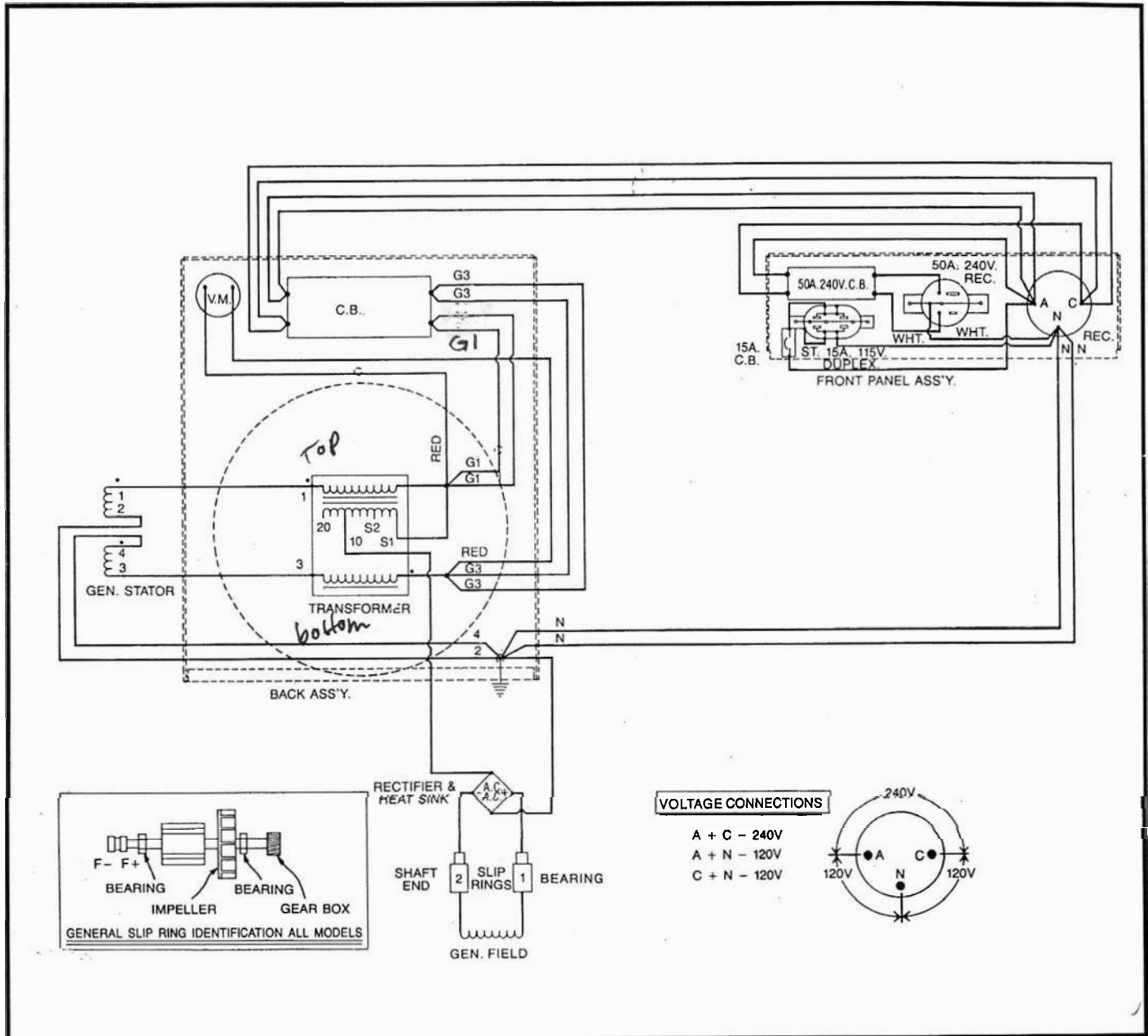

## REPLACEMENT PARTS LIST

REF. NO.	DESCRIPTION	QTY	35PTOC-3/E PART NO.	50PTOC-3/A PART NO.
001	Lockwasher 5/16	3	480-000	480-000
002	Capscrew 5/16-18 x 2	3	91672-009	91672-009
003	Screw #8-32 x 5/16	8	40746-000	40746-000
004	Lockwasher #8	4	6376-000	6376-000
005	Screw #8-32 x 1-1/2	4	10846-000	10846-000
006	Lockwasher 7/16	6	90570-000	90570-000
007	Capscrew 7/16-14 x 1.75	6	91256-000	91256-000
009	Nut	1	447-000	447-000
010	Eye Bolt	1	91137-000	91137-000
011	Sheet Metal Screw T-25	22	21698-001	21698-001
012	Set Screw	1	91347-000	91347-000
145	Spacer	4	62825-004	62825-004
146	Bracket	1	91170-000	91170-000
147	Shield	1	91171-000	91171-000
201	Cover	1	61135-001	61135-001
203	Louvered Panel	1	61137-002	61137-002
210	Rear Panel Assembly	1	61200-001	61200-002
212	Rear Panel (Bare)	1	61141-001	61141-001
244	Transformer	1	91187-000	<b>91397-002</b>
249	Front Panel (Bare)	1	61138-002	61138-002
252	Receptacle (Octopus)	1	91427-400	91427-400
253	Voltmeter	1	91370-000	91370-000
255	Circuit Breaker (50 AMP)	1	57030-000	57030-000
257	Receptacle (NEMA 6-50R)	1	57325-000	57325-000
<b>258</b>	Circuit Breaker (15 AMP)	1	91286-000	91286-000
259	Receptacle (NEMA 5-15)	1	24749-000	24749-000
263	Circuit Breaker			
	35PTOC-3 (150 AMP)	1	91447-007	
	50PTOC-3 (200 AMP)	1		91447-005
267	Plug (Octopus)	1	91859-000	91859-000
268	Retainer Plaster	1	91350-000	91350-000
270	Mounting Bracket	1	61139-001	61139-001
512	Cover (Impeller)	1	91337-000	91337-000
514	Stator & Shell Assembly	1	91148-400	91148- <b>029</b>
515	End Bracket	1	91212-000	91212-000
516	Retainer	1	91211-001	91211-001
517	Spacer	3	21264-000	21264-000
530	Rotor Assembly	1	91237-000	99301-000
532	Bearing (Tail)	1	91111-000	91111-000
534	Bearing (Drive End)	1	91112-000	91112-000
536	Retainer	1	91196-000	91196-000
571	Rectifier	1	91452-000	91452-000
572	Ring (Brush Holder)	1	91211-002	91211-002
573	Spacer (Fiber)	2	23532-000	23532-000
574	Brush	4	23607-000	23607-000
575	Brush Holder	4	59690-000	59690-000
576*	Barrier Spacer	4	59688-000	59688-000

\* Not Illustrated

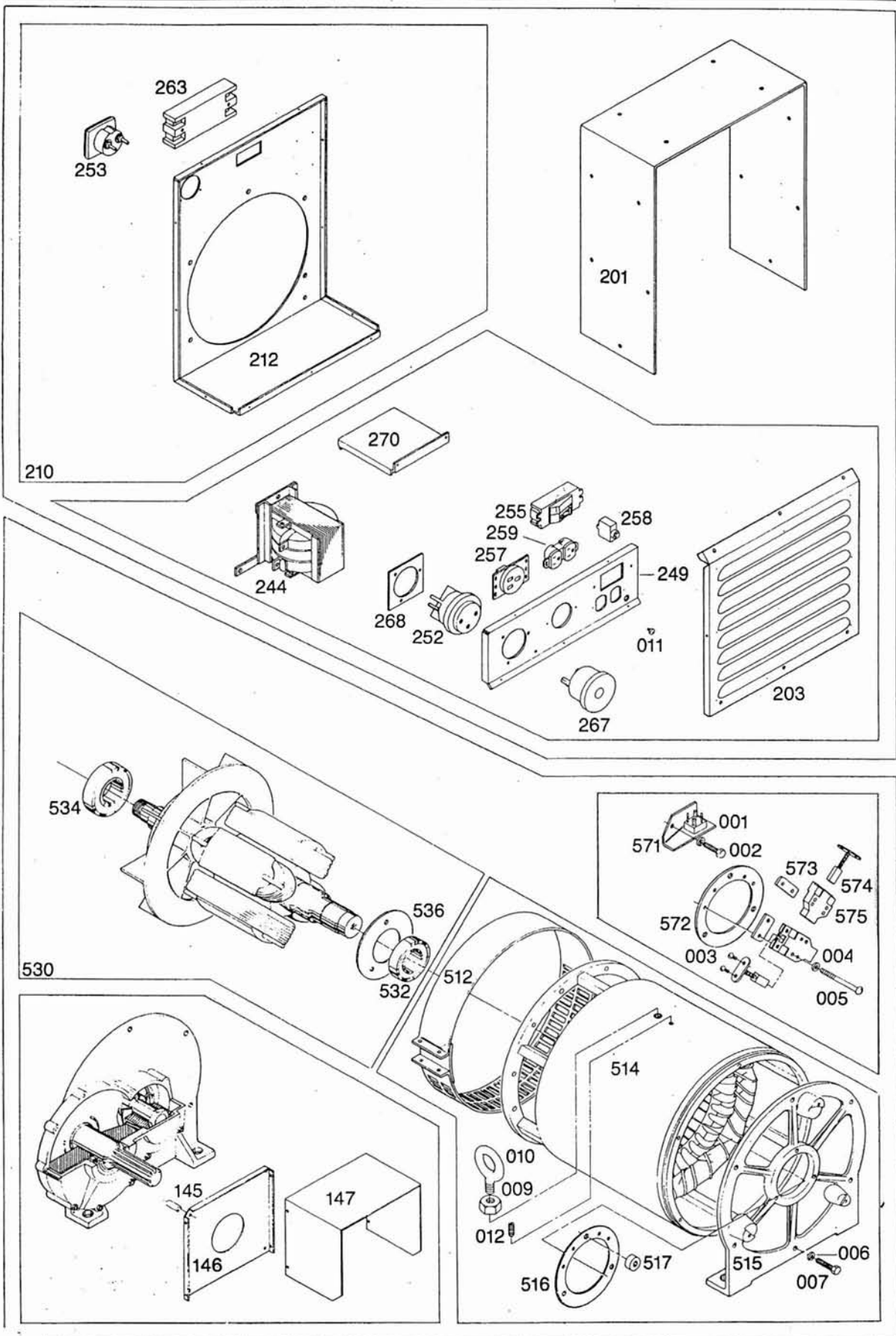

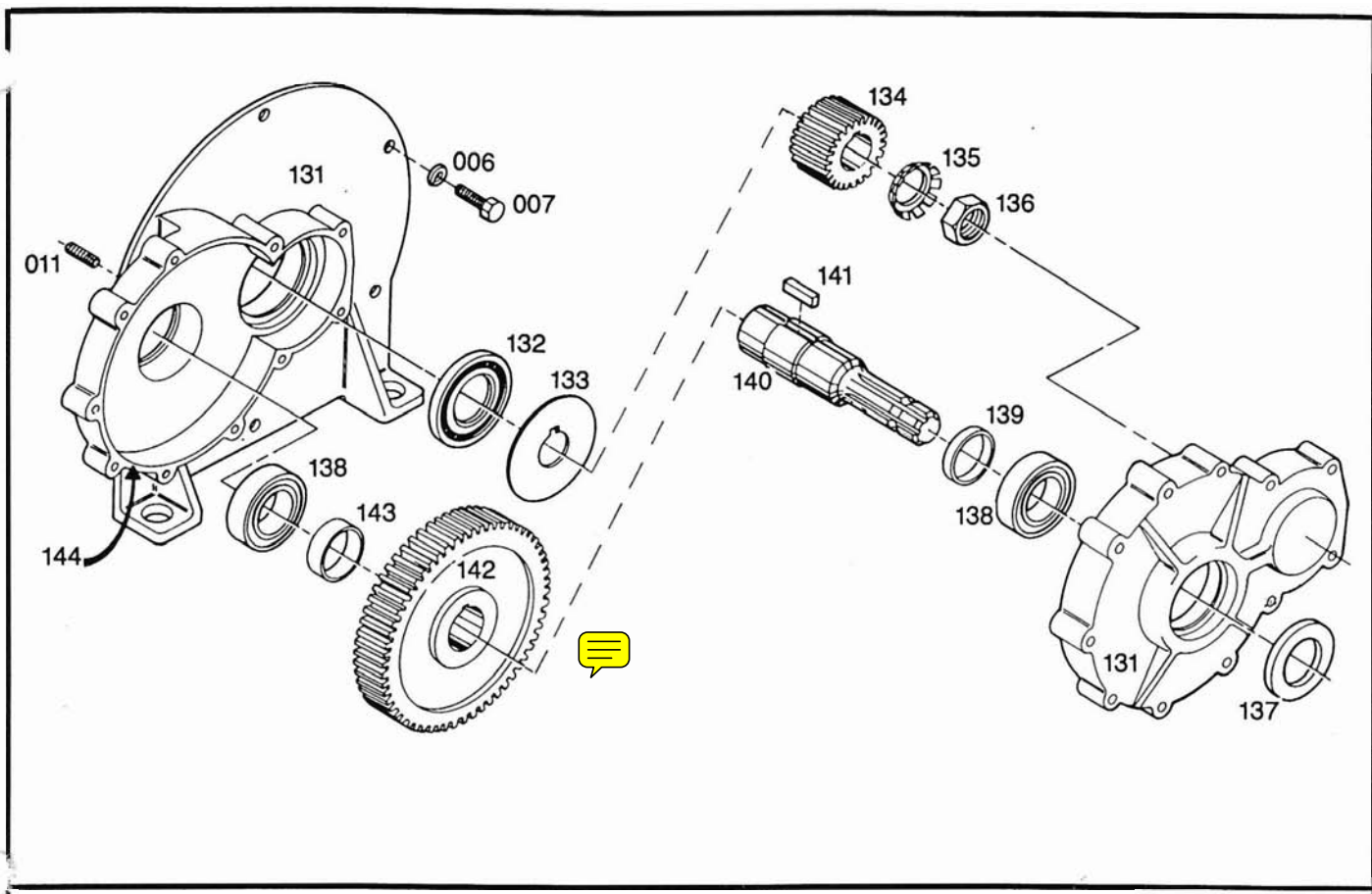

### GEARCASE REPLACEMENT PARTS ALL MODELS

REF NO	Description	QTY	PART NO
006	Lockwasher 7/16	4	90570-000
007	Capscrew 7/16-14 x 1.75	4	91256-000
011	Stud 7/16-14 x 1.75	2	91138-000
131	Machined Gear Case	1	91103-000
132	Rotor Shaft Seal	1	91116-000
133	Oil Slinger	1	91345-000
134	Pinion Gear 25 Tooth	1	91225-000
135	Lockwasher 1.396 External	1	50531-000
136	Rotor Shaft Nut 1 3/8-18	1	50532-000
137	Input Shaft Seal	1	91247-000
138	Bearing (6209)	2	91111-000
139	Front Spacer	1	91108-003
140	Input Shaft	1	91344-000
141	Key 1-15/32 x 1/2	1	91117-000
142	Drive Gear 84 Tooth	1	91118-000
143	Rear Spacer	1	91108-004
144	Gear Case Gasket	1	91104-000

**WINGO INC**  
 A Division of **DTP** Dyna Technology Inc  
 225 SOUTH CORDOVA AVE  
 LE CENTER MN 560578  
 507-357-6831