

**ILLUSTRATED
PARTS LIST**

PSS15B4W/A
PSS15B2W/A

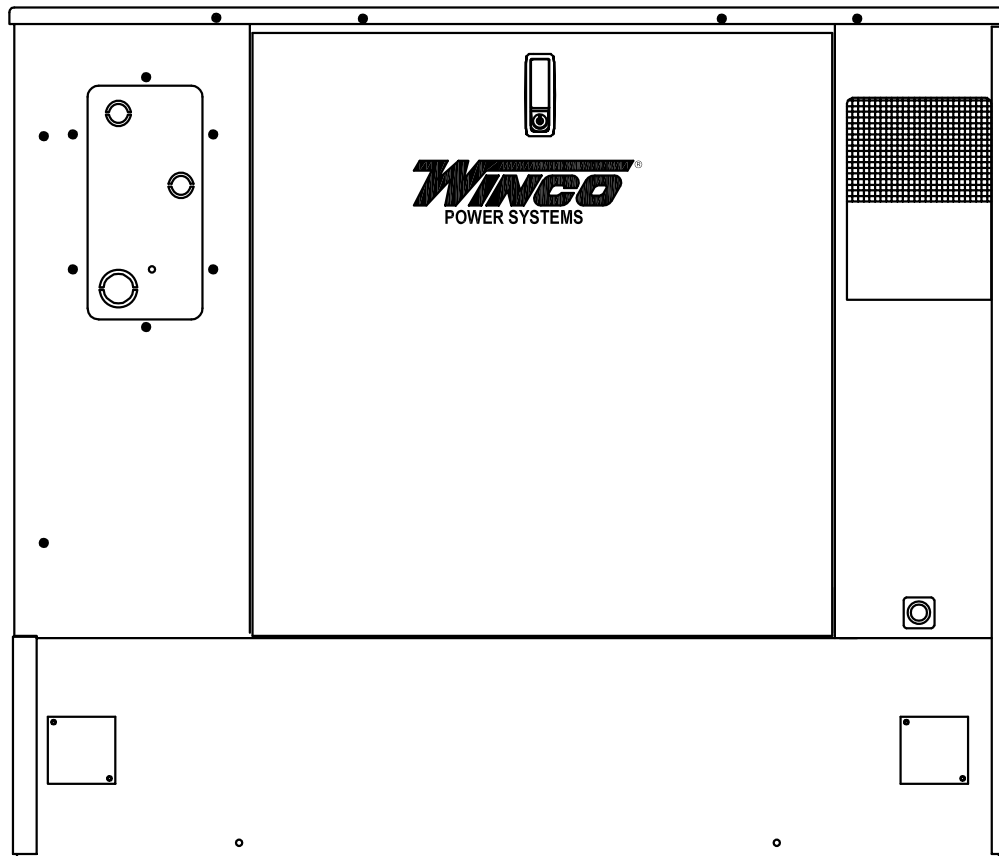

ENGINE & GENERATOR ASSEMBLY

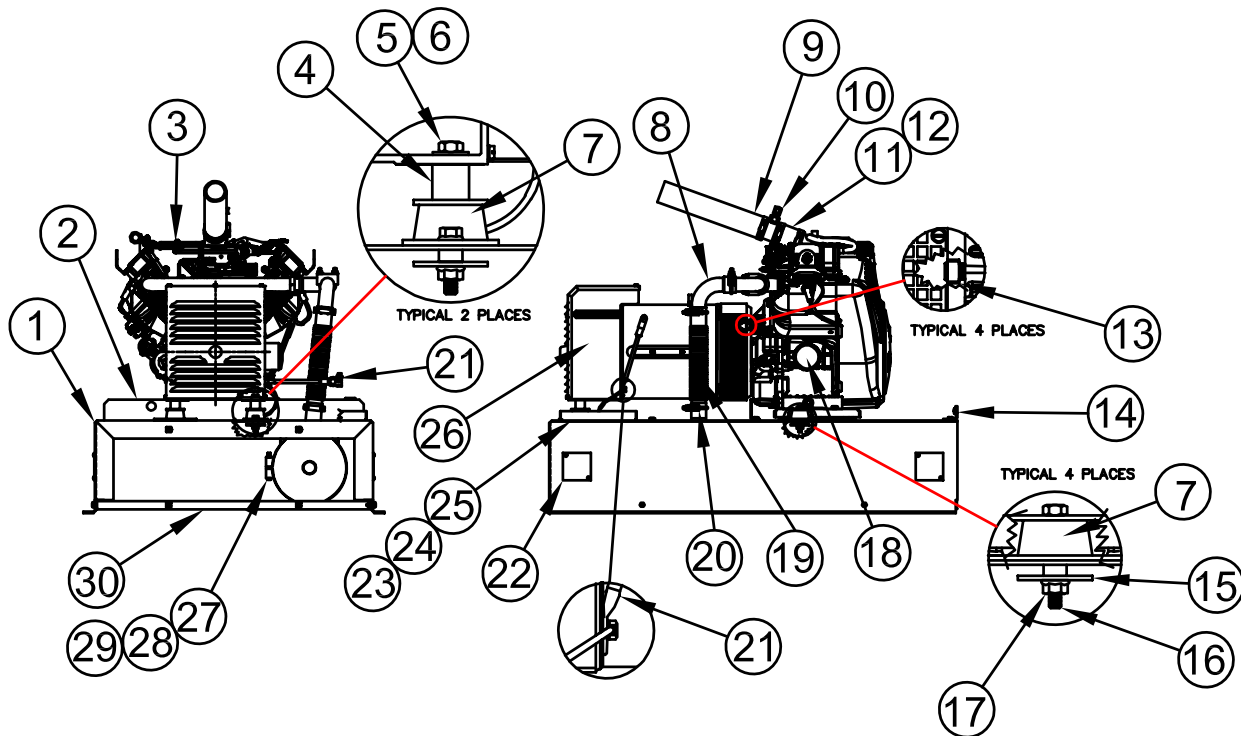

REF #	PART NUMBER	QTY	DESCRIPTION
1	16406-400	1	Base
2	16461-000	1	Base Stiffener
3	16427-000	1	Engine, Briggs & Stratton Model 543477-0127-E1
4	300040-3	2	Spacer
5	91658-015	2	3/8 - 16 X 4 Hex Head Bolt
6	20604-000	2	3/8 - 16 Washer
7	98807-000	6	Shock Mount
8	16404-002	2	1.5" I.D. Elbow
9	16481-002	1	2" I.D. X 12" Hose
10	16480-000	1	Fuel Adapter
11	16481-001	1	2" I.D. X 3" Hose
12	81018-002	3	Hose Clamp
13	93704-000	4	3/8 - 16 X 1 Socket Head Screw
14	16421-000	1	Front Base Stiffener
15	98806-000	8	2" O.D. X .406 I.D. Washer
16	91658-007	4	3/8 - 16 X 2 1/2 " Hex Head Bolt
17	16250-000	6	3/8 - 16 Hex Flange Nut
18	B&S 842921	1	Oil Filter
19	16458-001	1	Flexible Exhaust
20	93489-015	4	Exhaust Clamp

REF #	PART NUMBER	QTY	DESCRIPTION
21	22097-007	1	Negative Battery Cable
22	300385-411	4	Lifting Hole Cover
23	300430-400	1	Battery Tray
24	16026-403	1	Battery Tray Support Channel
25	16026-404	1	Battery Tray Support Bracket
26	16428-000	1	Generator, Mecc Alte Spa Model ECO3-2L/2 
27	350590-3	1	Muffler
28	350264-7	2	Muffler Bands
29	16237-001	1	Spark Arrestor
30	15637-002	1	Base Channel
NI	16469-010	1	Air Filter
NI	B&S 792015	2	Spark Plugs
NI	16479-000	1	Exhaust Manifold
NI	300349-1	1	Oil Drain Adapter
NI	96187-001	1	Oil Drain Gasket
NI	21857-001	1	Pipe Coupling
NI	16456-016	1	3/8 X 8" Pipe Nipple
NI	643-001	1	3/8 Pipe Plug
NI	16428-411	1	Voltage Regulator
NI	Not Illustrated		

MECC ALTE SPA GENERATOR
MANUAL AVAILABLE AT
meccalte.com

NG/LP FUEL ASSEMBLY

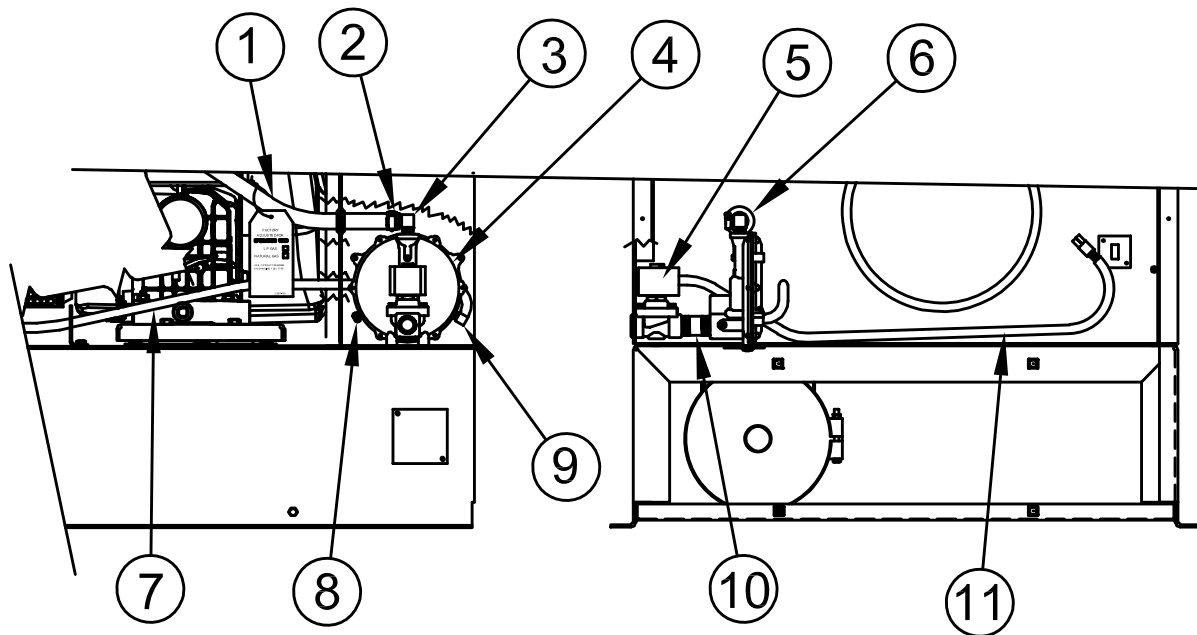

REF #	PART NUMBER	QTY	DESCRIPTION
1	16278-002	1	Fuel Hose
2	81018-005	2	Hose Clamp
3	92382-000	1	Hose Fitting
4	55559-002	1	Demand Regulator
5	42942-000	1	Fuel Solenoid
6	16302-000	1	Grommet
7	40078-031	3 FT	Hose
8	644-000	1	1/8" Pipe Plug
9	81827-001	1	1/8" 90° Hose Barb
10	54074-006	1	3/4" X 1-1/2" Pipe Nipple
11	16447-007	1	Fuel Solenoid Harness

GENERATOR DIVIDER ASSEMBLY

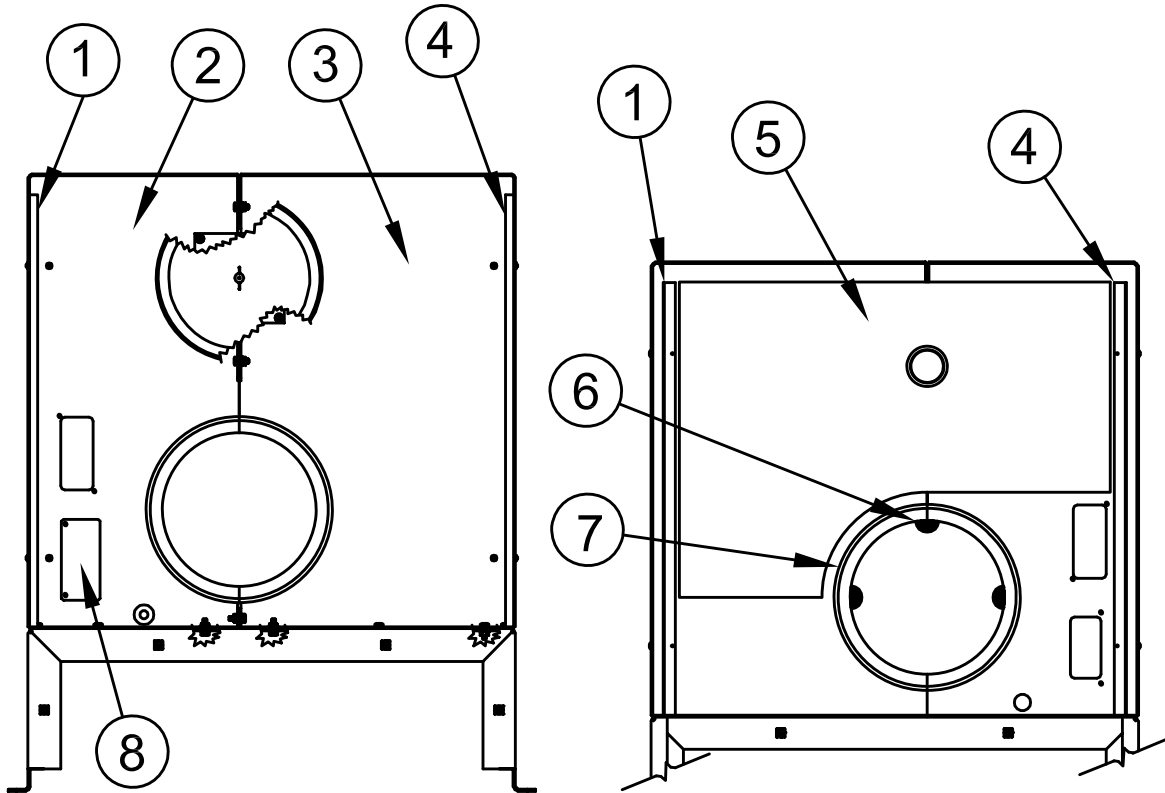

REF #	PART NUMBER	QTY	DESCRIPTON
1	15681-003	2	Door Stop
2	16417-400	1	Left Generator Divider
3	16414-400	1	Right Generator Divider
4	15681-004	2	Door Stop
5	16424-410	1	Foam
6	92421-001	3	1" X 1" X 1" Foam
7	15287-014	2	Air Seal
8	16440-400	1	Oil Heater Cover Plate

ENGINE PARTITION ASSEMBLY

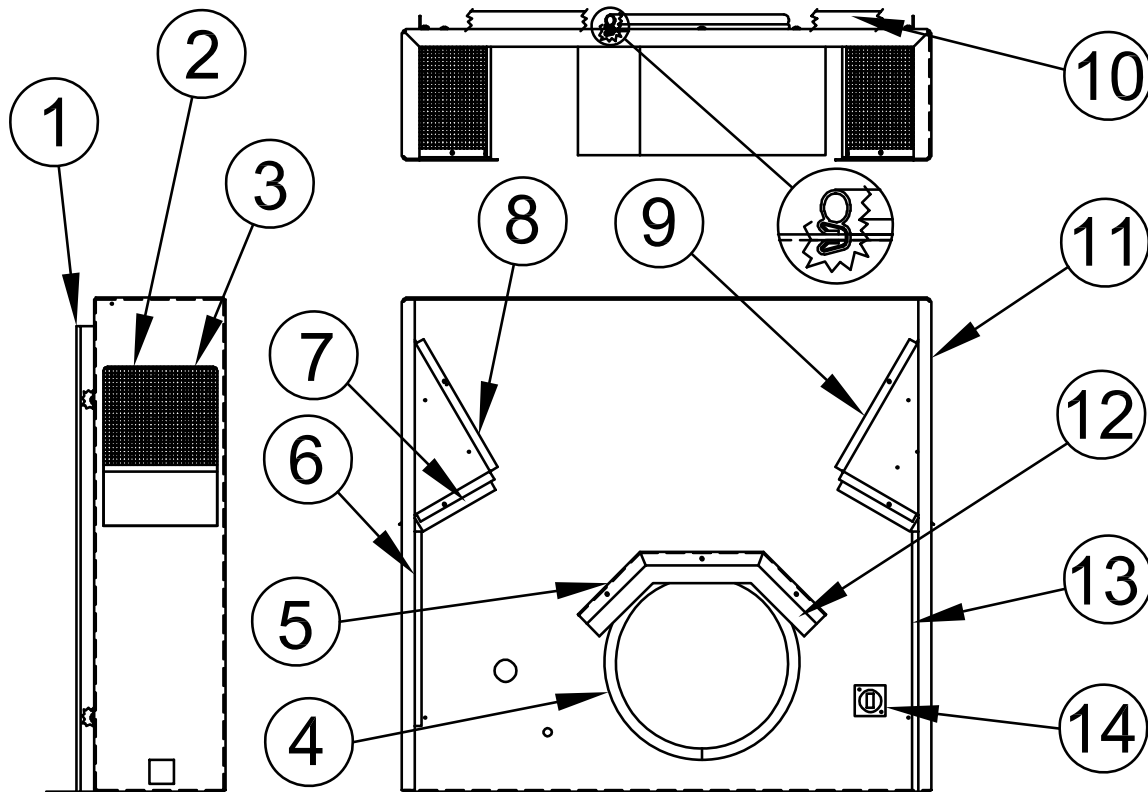

REF #	PART NUMBER	QTY	DESCRIPTION
1	15681-404	2	Door Stop
2	16444-000	8	Screen Keeper
3	91644-008	2	Intake Screen
4	16338-005	1	Air Seal (33 - 3/4")
5	16464-400	1	Blower Inlet Baffle
6	16424-406	1	Foam Part
7	16424-408	2	Foam Part
8	16353-405	1	Right Air Duct
9	16353-404	1	Left Air Duct
10	16424-409	1	Foam Part
11	16413-400	1	Divider
12	16424-405	1	Foam Part
13	16424-407	1	Foam Part
14	16440-401	1	Connector Cover Plate

ENCLOSURE ASSEMBLY

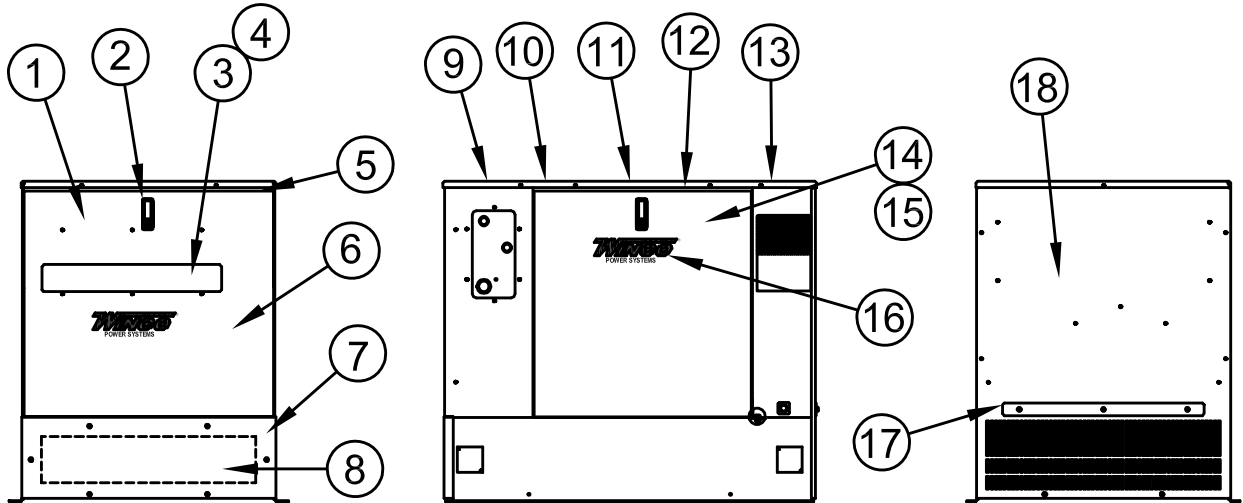

REF #	PART NUMBER	QTY	DESCRIPTION
1	16360-404	1	Rear Door
2	95229-005	3	Door Latch
3	300416-401	1	Air Inlet Grill
4	300417-401	1	Air Inlet End
5	16415-402	1	Rear Door Stop
6	16424-411	1	Foam Part
7	16466-400	1	Rear Base Plate
8	16424-412	1	Foam Part
9	16424-404	1	Foam, Rear Roof
10	16422-400	1	Roof
11	16424-402	1	Foam, Middle Roof
12	16415-400	2	Door Stop
13	16424-403	1	Foam, Front Roof
14	16360-401	2	Side Door
15	16424-401	2	Foam, Door
16	Silk Screen	Ref	Winco Logo
17	16467-000	1	Front Housing Stiffener
18	16414-400	1	Front Housing

AC CONNECTION ASSEMBLY

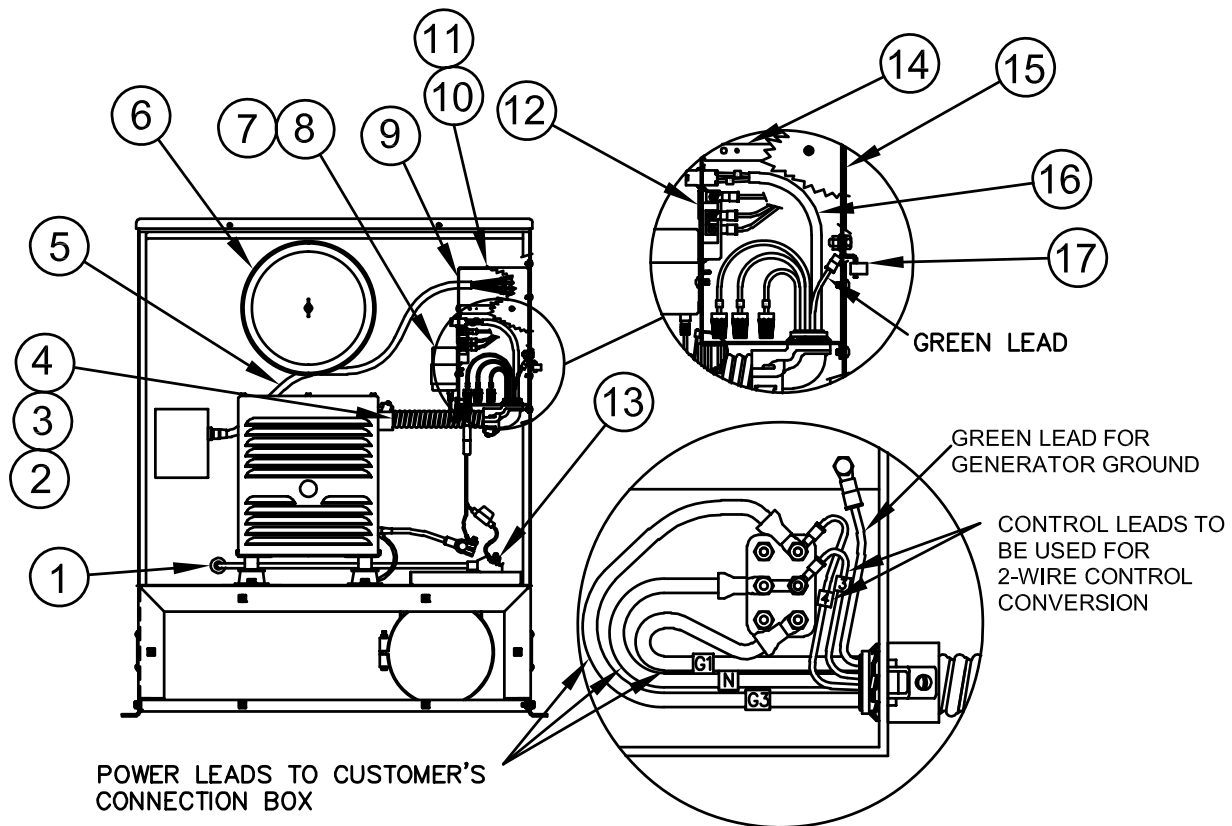

REF #	PART NUMBER	QTY	DESCRIPTION
1	23917-002	1	Grommet
2	16482-001	1	1" Straight Conduit Fitting
3	16483-001	1	Flexible Conduit
4	16482-000	1	1" 90° Conduit Fitting
5	16447-010	1	Wiring Harness
6	16469-000	1	Air Filter Canister/Silencer
7	16287-000	1	Battery Tender
8	300308-410	1	Hold Down Bracket
9	23917-000	1	Grommet
10	300278-409	1	Terminal Box Enclosure
11	300321-410	1	Enclosure Side Panel
12	24749-000	1	Duplex Receptacle
13	22097-001	1	Positive Battery Cable
14	300309-410	1	Terminal Box Divider
15	16465-400	1	Conduit Knockout Plate
16	Reference	1	2-Wire Control Leads
17	48042-000	1	Ground Lug
NI	300310-410	1	Terminal Box Cover
NI	Not Illustrated		

DC ELECTRICAL ASSEMBLY

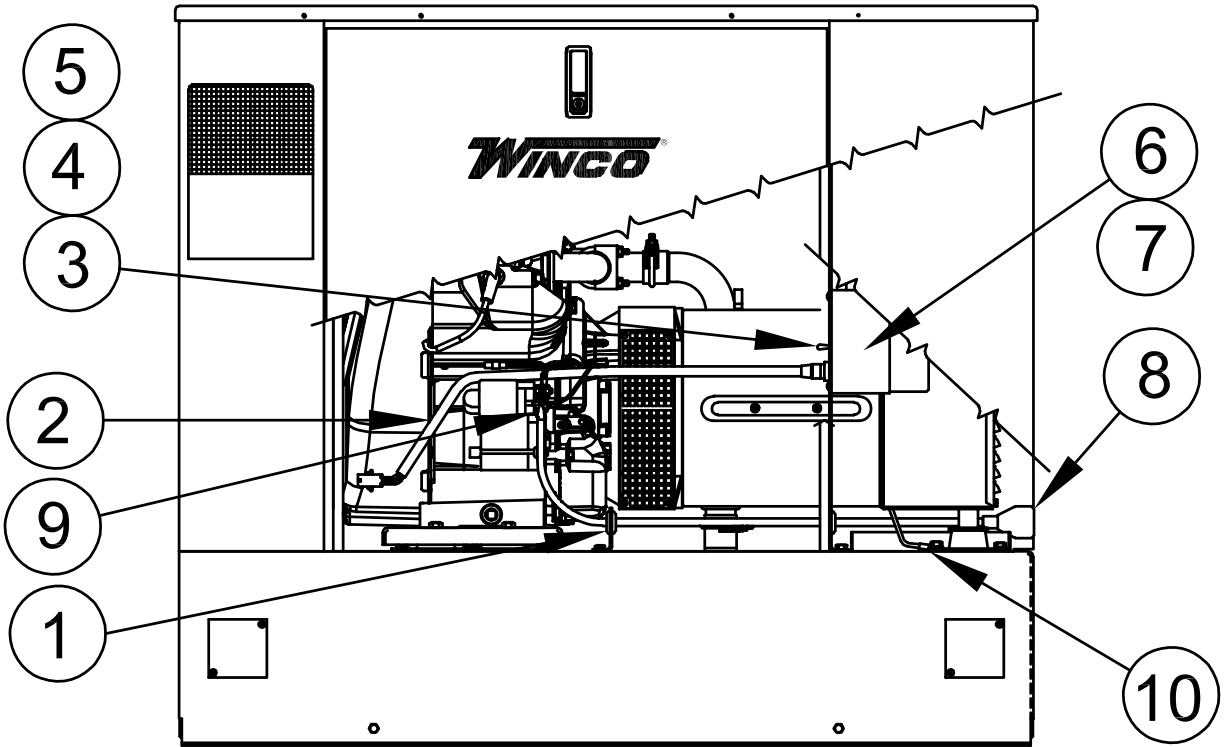

REF #	PART NUMBER	QTY	DESCRIPTION
1	23917-000	1	Grommet
2	16447-008	1	Engine Control Harness
3	71215-002	1	Toggle Switch, SPDT (4-Wire)
4	95894-001	1	Toggle Switch, DP (4-Wire)
5	71216-001	1	Toggle Switch, DPDT (2-Wire)
6	15764-405	1	Engine Control Module (4-Wire)
7	15764-407	1	Engine Control Module (2-Wire)
8	95901-002	1	Battery Cable Insulator (Post)
9	16145-000	1	Battery Cable Insulator (Bolt)
10	9769-157	1	Lead Wire Assembly

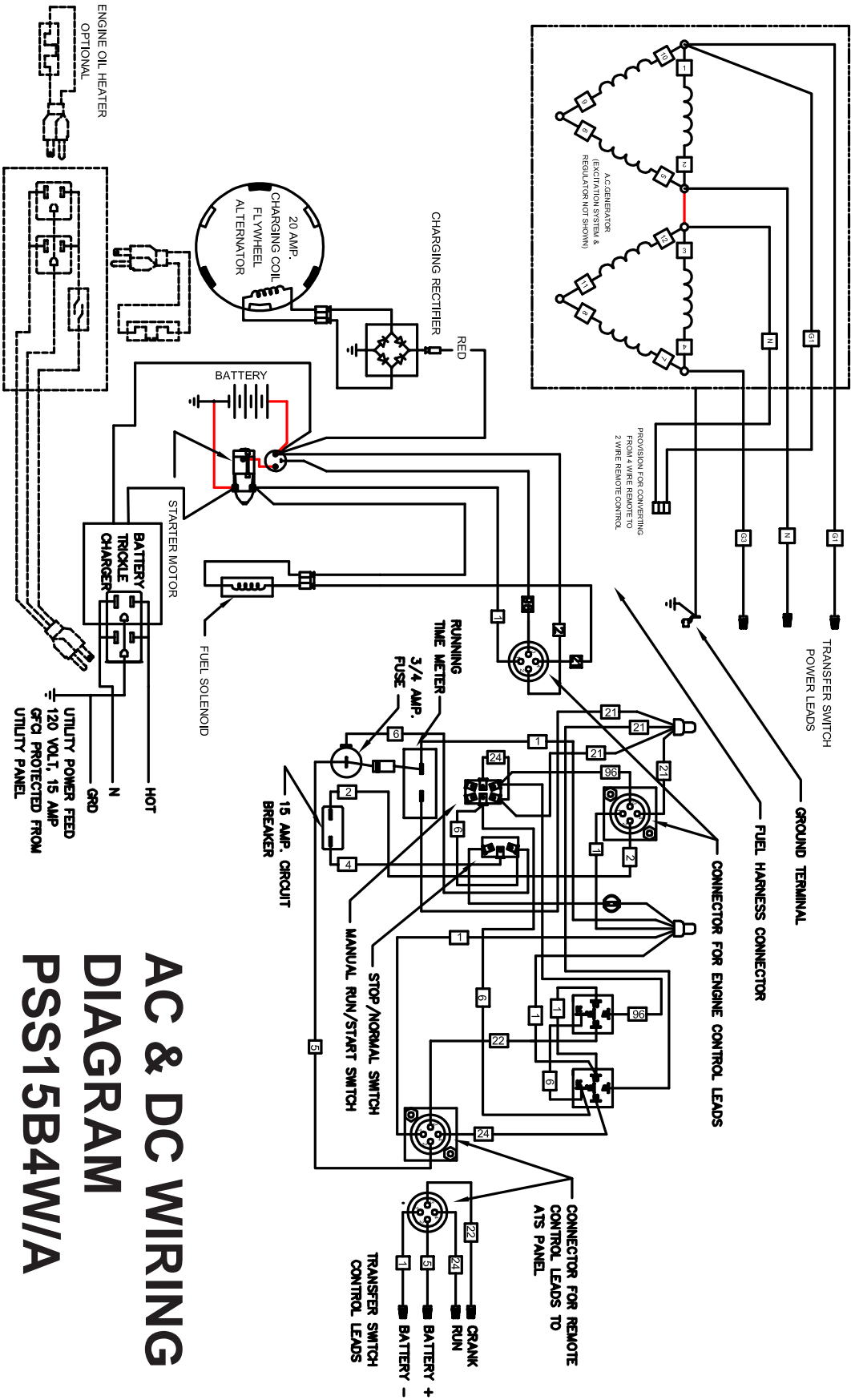

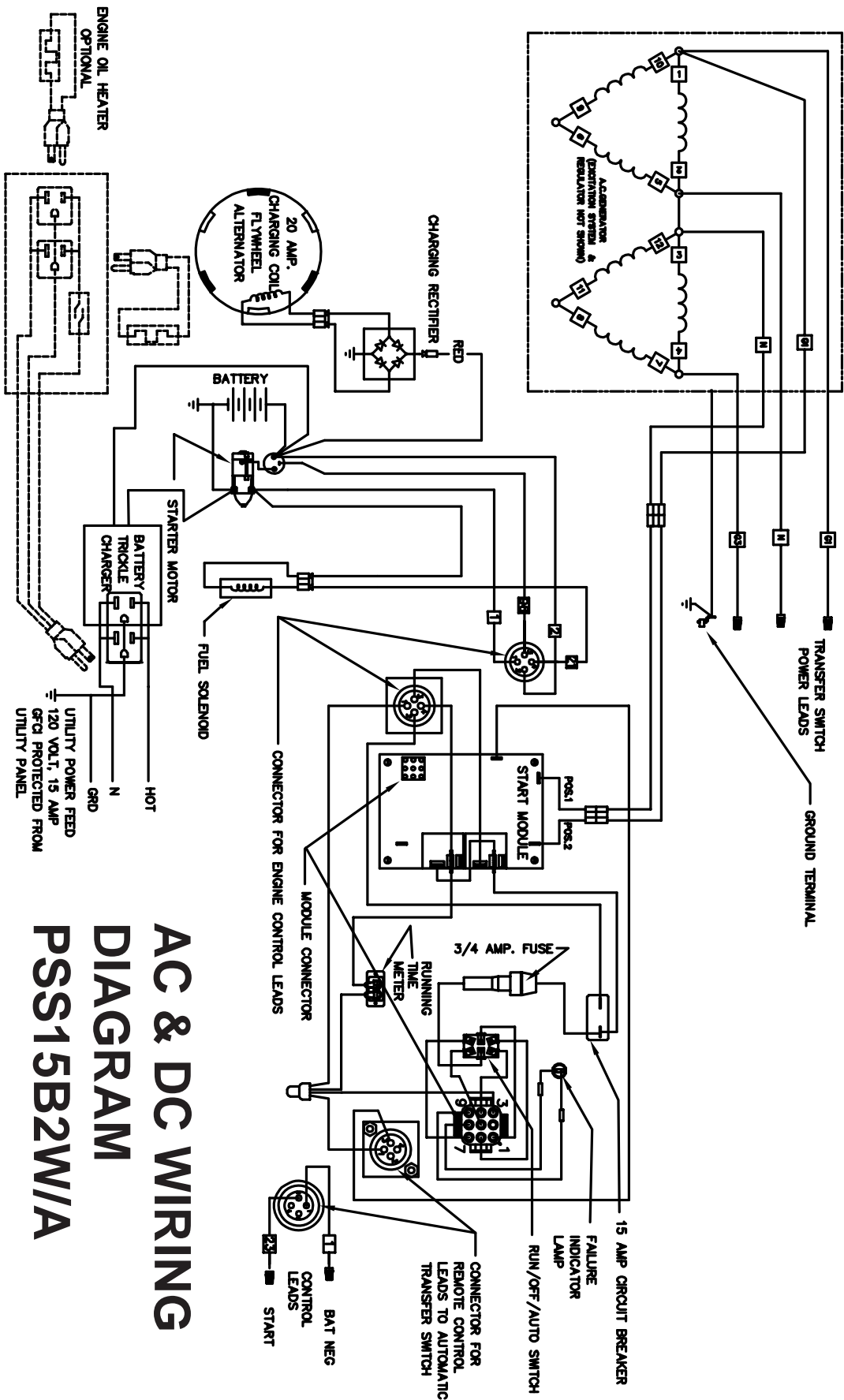

AC & DC WIRING DIAGRAM PSS15B2W/A

AC & DC SCHEMATIC PSS15B4W1A

LEGEND

- | | |
|-----|------------------------------|
| AL | ALARM LAMP (SYSTEM OFF) |
| BC | BATTERY FLOAT CHARGER |
| CB | CIRCUIT BREAKER |
| CR1 | START CONTROL RELAY |
| CR2 | RUN CONTROL RELAY |
| EM | ENGINE MAGNETO |
| FS | FUEL SOLENOID |
| OPS | OIL PRESSURE SWITCH |
| RTM | RUNNING TIME METER |
| SC | START CONTACTOR |
| SM | STARTER MOTOR |
| TVS | TRANSIENT VOLTAGE SUPPRESSOR |

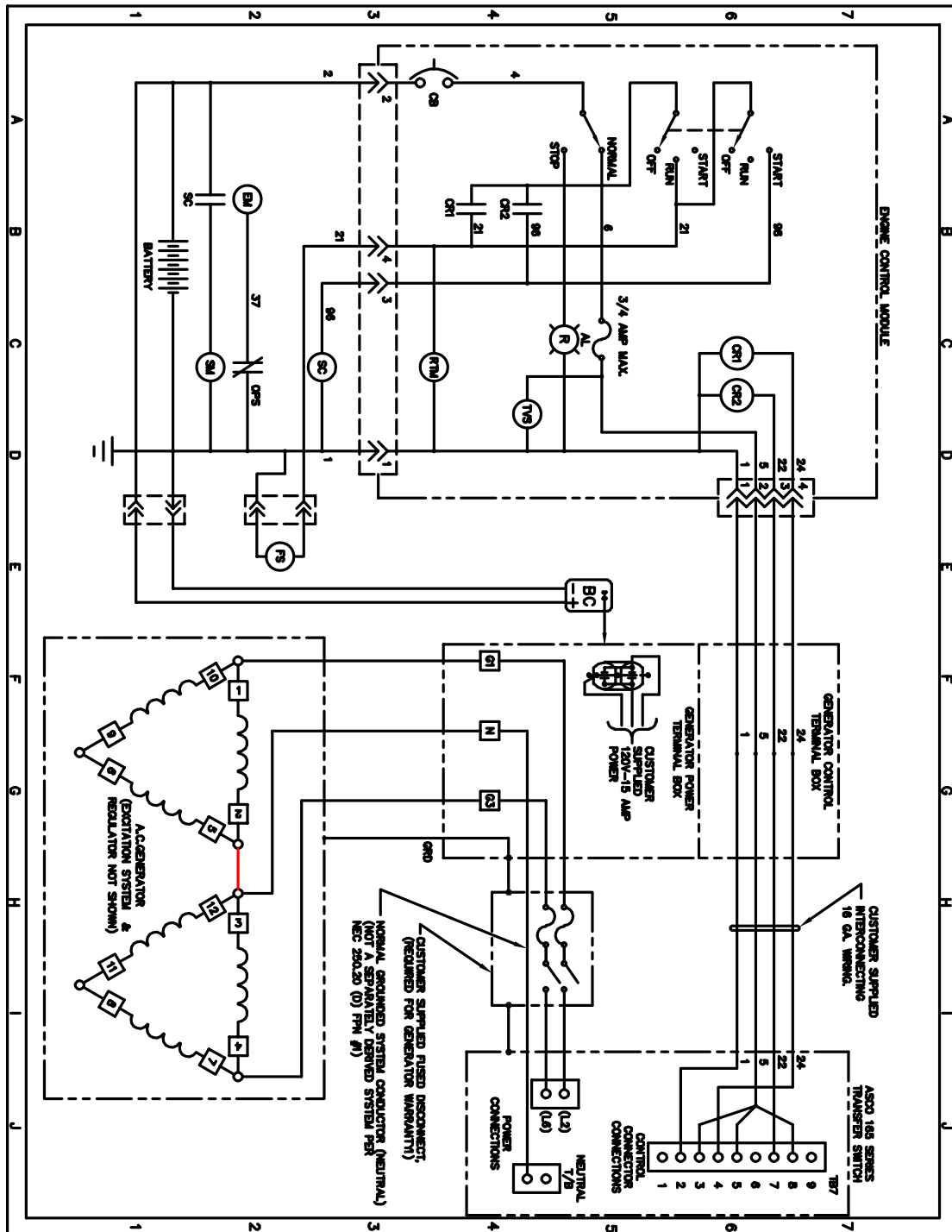

AC & DC SCHEMATIC PSS15B2W-4/A

LEGEND

AL	ALARM LAMP (FAILURE TO START)
BC	BATTERY FLOAT CHARGER
CB	CIRCUIT BREAKER
FS	FUEL SOLENOID
G1, G3 & N	GENERATOR LEAD IDENTIFICATION
GEN	GENERATOR
L1, L3 & N	LINE TERMINALS
N	NEUTRAL
RSSC	REMOTE START STOP CONTROL MODULE
RTM	RUNNING TIME METER
SC	STARTER MOTOR CONTACTOR
SM	STARTER MOTOR

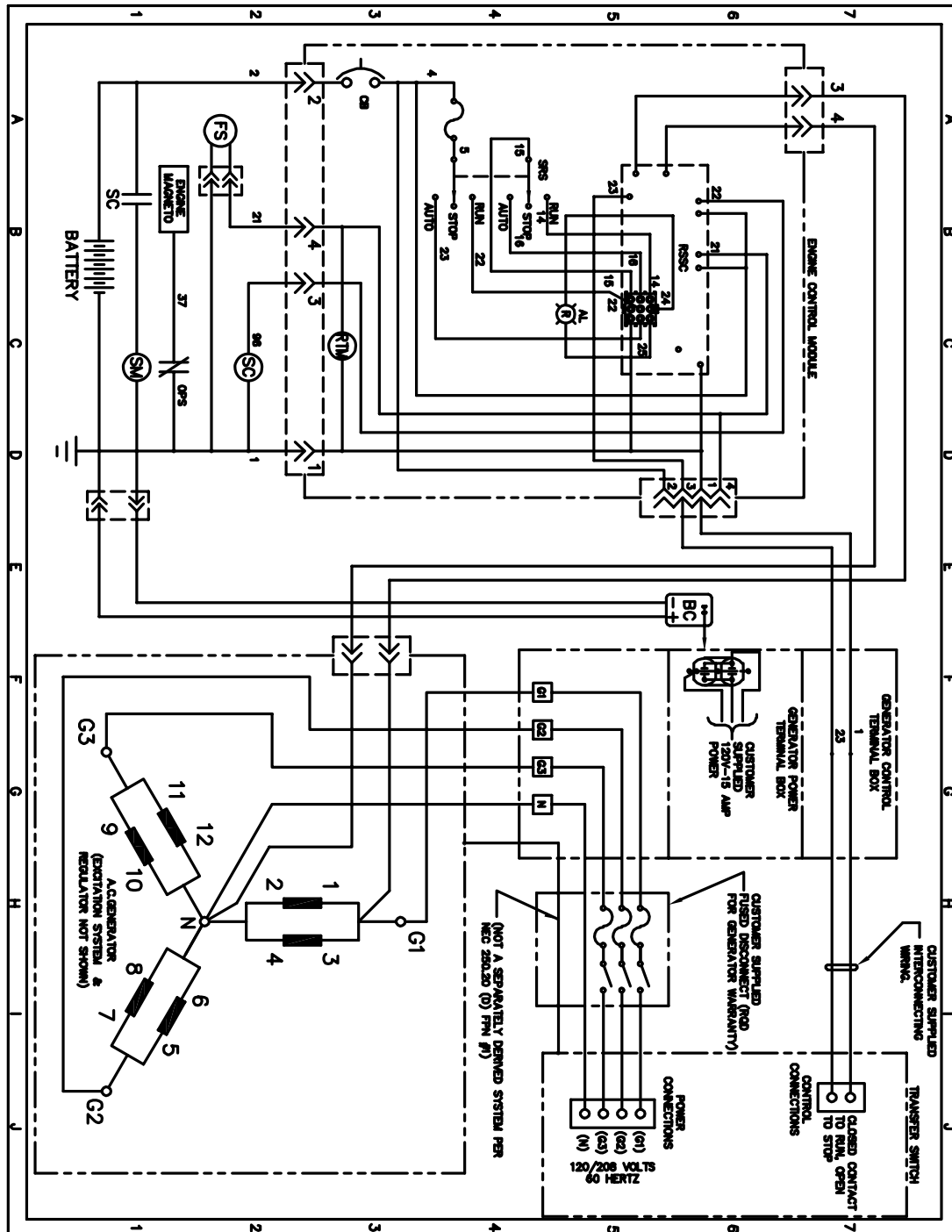

AC & DC SCHEMATIC PSS15B2W-171/A

LEGEND

- | | |
|------------|----------------------------------|
| AL | ALARM LAMP (FAILURE TO START) |
| BC | BATTERY FLOAT CHARGER |
| CB | CIRCUIT BREAKER |
| FS | FUEL SOLENOID |
| G1, G3 & N | GENERATOR LEAD IDENTIFICATION |
| GEN | GENERATOR |
| L1, L3 & N | LINE TERMINALS |
| N | NEUTRAL |
| RSSC | REMOTE START STOP CONTROL MODULE |
| RTM | RUNNING TIME METER |
| SC | STARTER MOTOR CONTACTOR |
| SM | STARTER MOTOR |

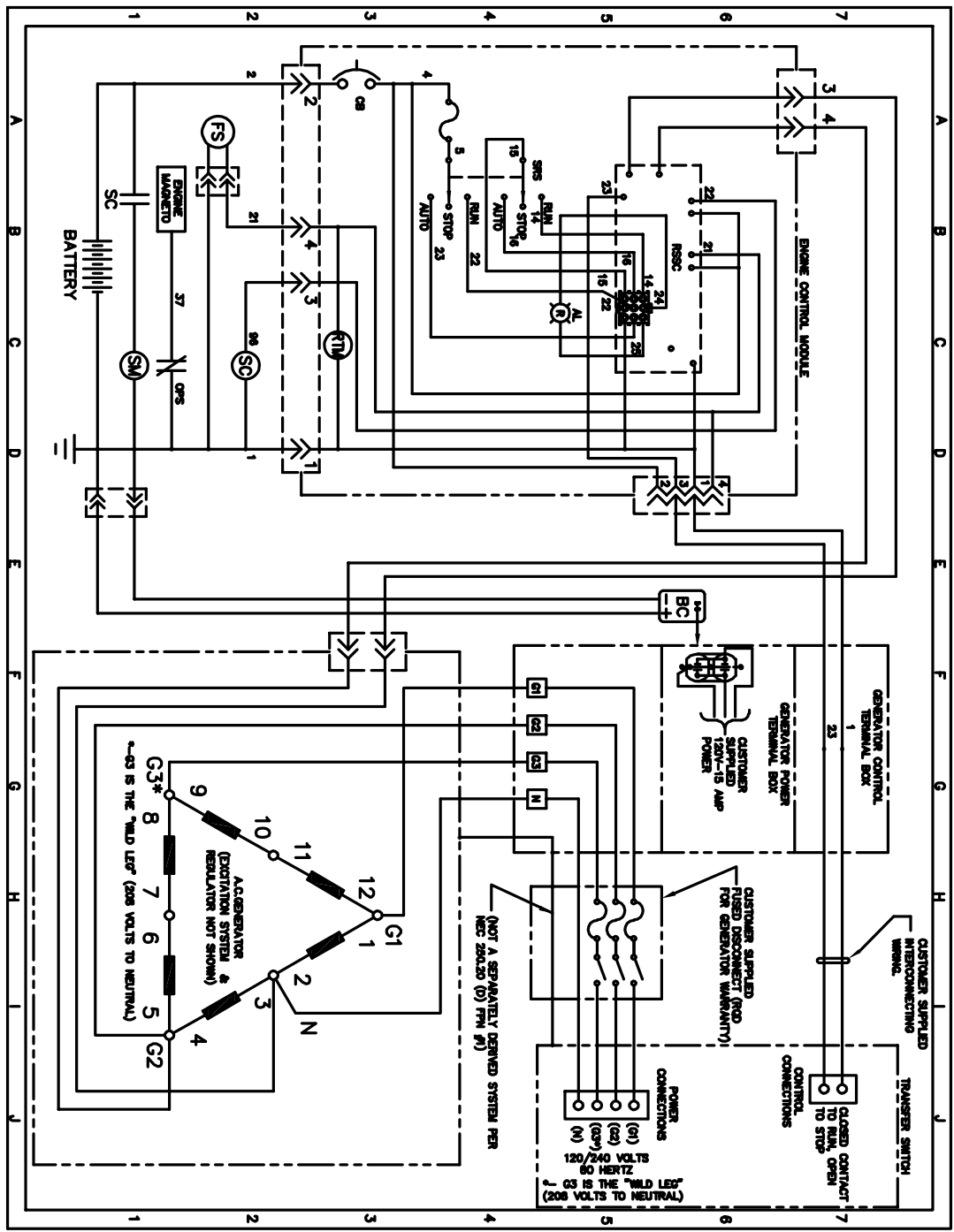

AC & DC SCHEMATIC PSS15B2W-18/A

- LEGEND**
- AL ALARM LAMP (FAILURE TO START)
 - BC BATTERY FLOAT CHARGER
 - CB CIRCUIT BREAKER
 - FS FUEL SOLENOID
 - G1, G2, G3 & N GENERATOR LEAD IDENTIFICATION
 - GEN GENERATOR
 - N NEUTRAL
 - RSSC REMOTE START STOP CONTROL MODULE
 - RTM RUNNING TIME METER
 - SC STARTER MOTOR CONTACTOR
 - SM STARTER MOTOR

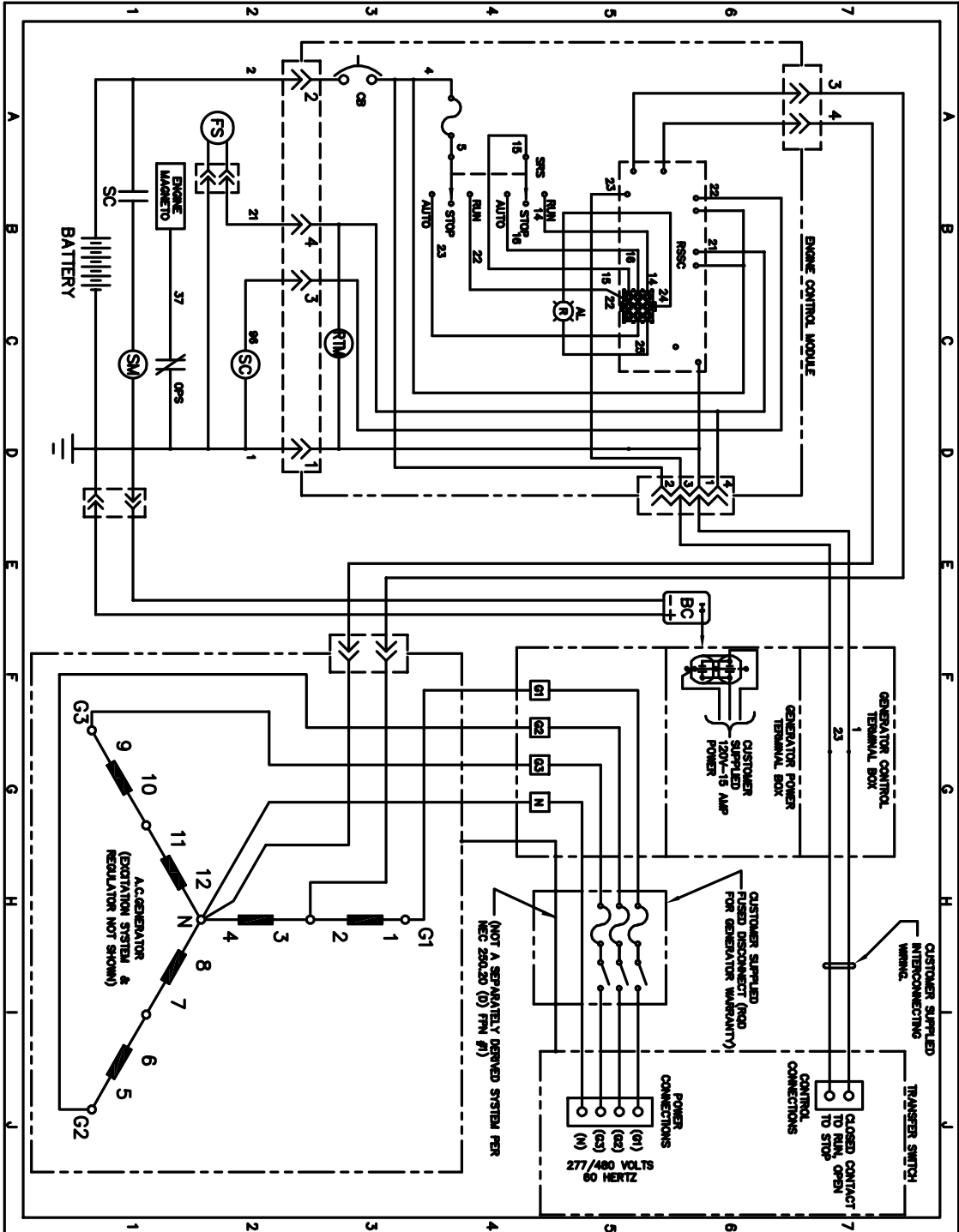

WINCO INC[®]

*A Division of **DTE** Dyna Technology Inc*

WINCO INC.

225 S. CORDOVA AVE.

LECENTER, MN 56057

507-357-6821

SERVICE DEPT.

507-357-6831