



ILLUSTRATED PARTS LIST

ULPSS30-3/C & /D

ULPSS30-4/C & /D

ULPSS30-17/C & /D

ULPSS30-18/C & /D

**WITH DSE 7110 & DSE7310
ENGINE CONTROL**

**225 S. CORDOVA AVE.
LECENTER, MN 56057
507-357-6821
SERVICE DEPT.
507-357-6831
wincogen.com**

GENERATOR ASSEMBLY

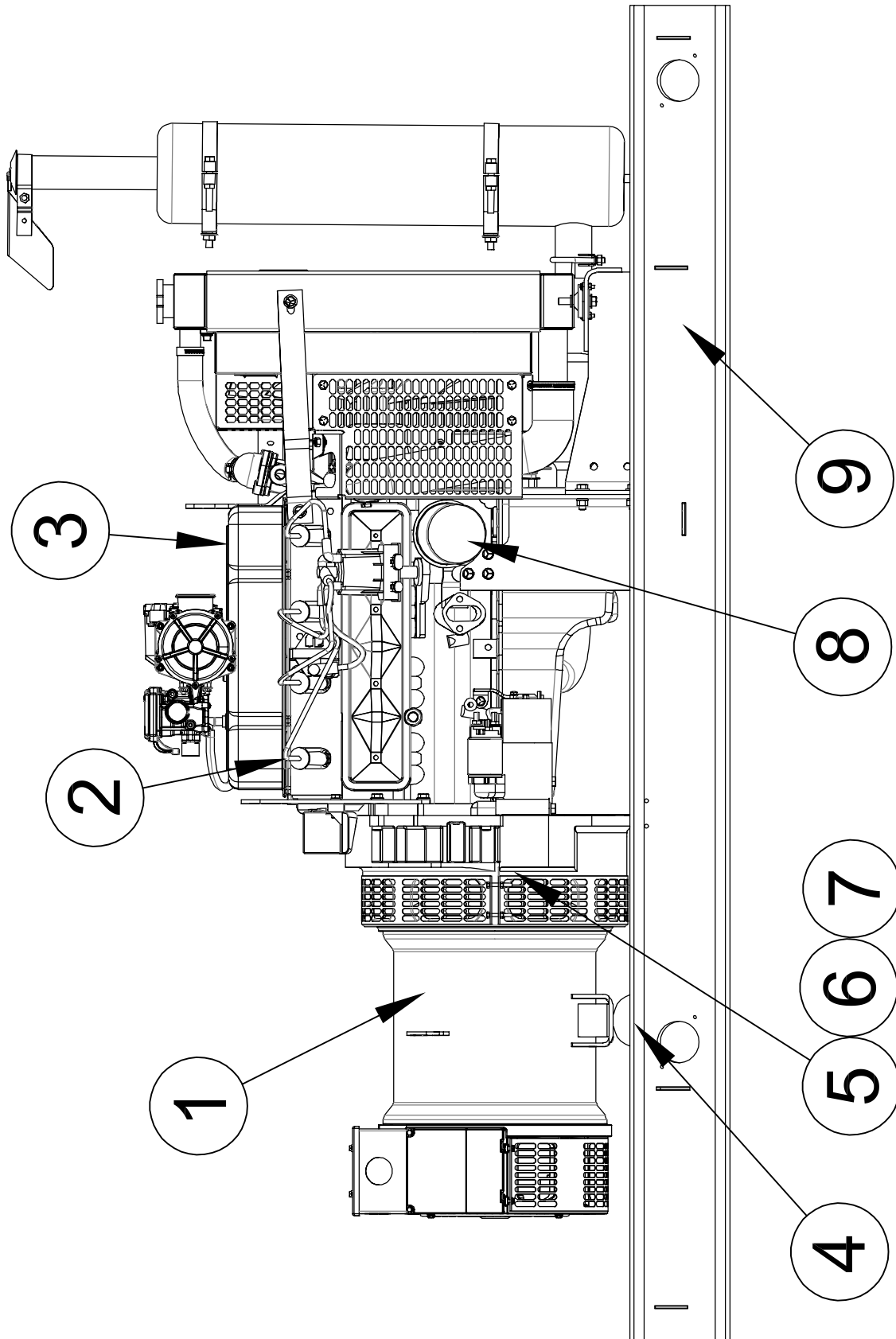

| REF # | PART NUMBER | QTY | DESCRIPTION |
|-------|------------------|--------|-------------------------------------|
| 1 | SEE TABLE | 1 | Stanford Newage Generator |
| 2 | R42LTS or R44LTS | 4* | Spark Plug |
| 3 | 351987-1 | 1 | Engine, GM 3.0 Liter |
| 4 | 98956-001 | 4 | Shock Mount |
| 5 | 96000-004 | 11 | 3/8-16 X 1.5" Bolt |
| 6 | 23597-003 | 1 | 3/8-16 X 2.25" Bolt |
| 7 | 481-001 | 12 | Lock Washer |
| 8 | PF454 | 1* | Oil Filter |
| 9 | 99309-130 | 1 | Welded Base Assembly |
| NI | 99317-001 | 1 | Battery Tray |
| NI | 55220-036 | 1 | Negative (-) Battery Cable |
| NI | 53220-045 | 1 | Positive (+) Battery Cable |
| NI | 97294-003 | 1 | Air Filter Assembly Impco AF1-15 |
| NI | 55505-000 | 6 FT | 3/8" Hose (Oil Drain) |
| NI | 62625-004 | 1.5 FT | Reflective Heat Sleeve |
| NI | 98906-006 | 1 | Oil Drain Valve |
| NI | 350818-2 | 1 | Voltage Regulator AS440UL |
| NI | 99420-021 | 1 | DC Engine Harness |
| NI | 72036-015 | 1 | 2 Amp Battery Charger |
| NI | 16018-000 | 1 | Air Filter Support |
| * | AC Delco Part # | | |
| NI | Not Illustrated | | |

| | | |
|--|------------------------------------|--|
| STAMFORD NEWAGE MODEL # | PI144G1J 4-LEAD | PI144H1L 12-LEAD |
| WINCO PART # | 350005-011 | 350005-007 |
| WINCO MODEL #'S | ULPSS30-3/C ULPSS30-3/D | ULPSS30-4/C & D ULPSS30-17/C & D ULPSS30-18/C & D |

ENGINE CONTROL ASSEMBLY /C WITH DSE7110

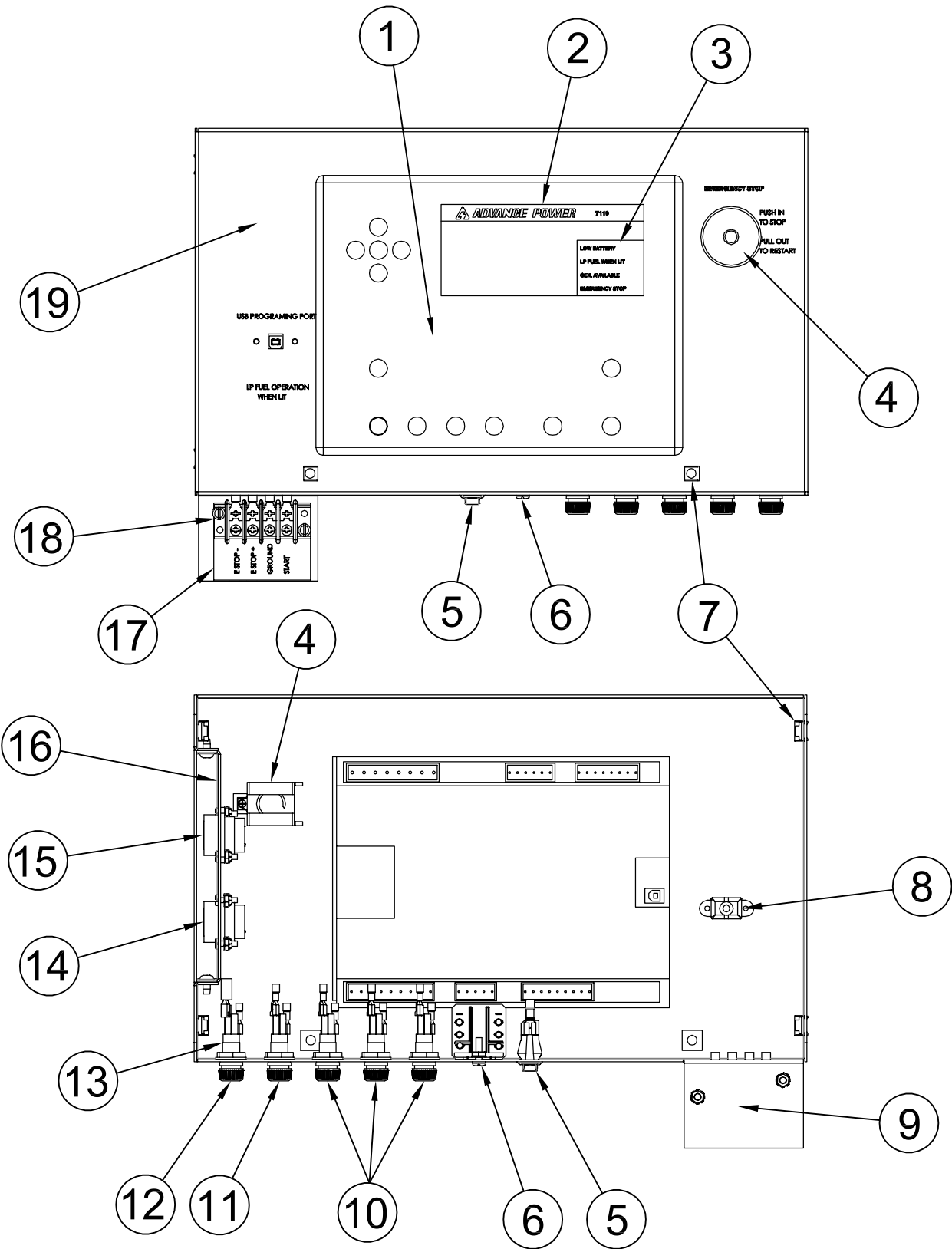

| REF # | PART NUMBER | QTY | DESCRIPTION |
|-------|-----------------|-----|-------------------------|
| 1 | 351112-3 | 1 | DSE 7110 Controller |
| 2 | 1660-001 | 1 | Advance Power Insert |
| 3 | 16601-003 | 1 | LED Legend Insert |
| 4 | 99783-002 | 1 | Emergency Stop Switch |
| 5 | 64089-000 | 1 | SPST Rocker Switch |
| 6 | 59944-017 | 1 | DPDT Relay 12VDC 10 Amp |
| 7 | 92495-000 | 6 | Retainer Nut |
| 8 | 92844-005 | 1 | USB Cable |
| 9 | 99826-196 | 1 | DC Box |
| 10 | 95064-002 | 3 | 2 Amp Fuse |
| 11 | 95064-000 | 1 | 3 Amp Fuse |
| 12 | 95064-006 | 1 | 10 Amp Fuse |
| 13 | 2489-001 | 5 | Fuse Holder |
| 14 | 96925-006 | 1 | 16 Pin Connector |
| 15 | 96925-002 | 1 | 14 Pin Connector |
| 16 | 351900-11 | 1 | Connector Plate |
| 17 | 64576-019 | 1 | Remote Terminal Decal |
| 18 | 80623-008 | 1 | 4 Point Terminal Block |
| 19 | 99055-037 | 1 | Control Panel |
| NI | 99783-002 | 1 | E Stop Contact |
| NI | Not Illustrated | | |

ENGINE CONTROL ASSEMBLY /D WITH DSE7310

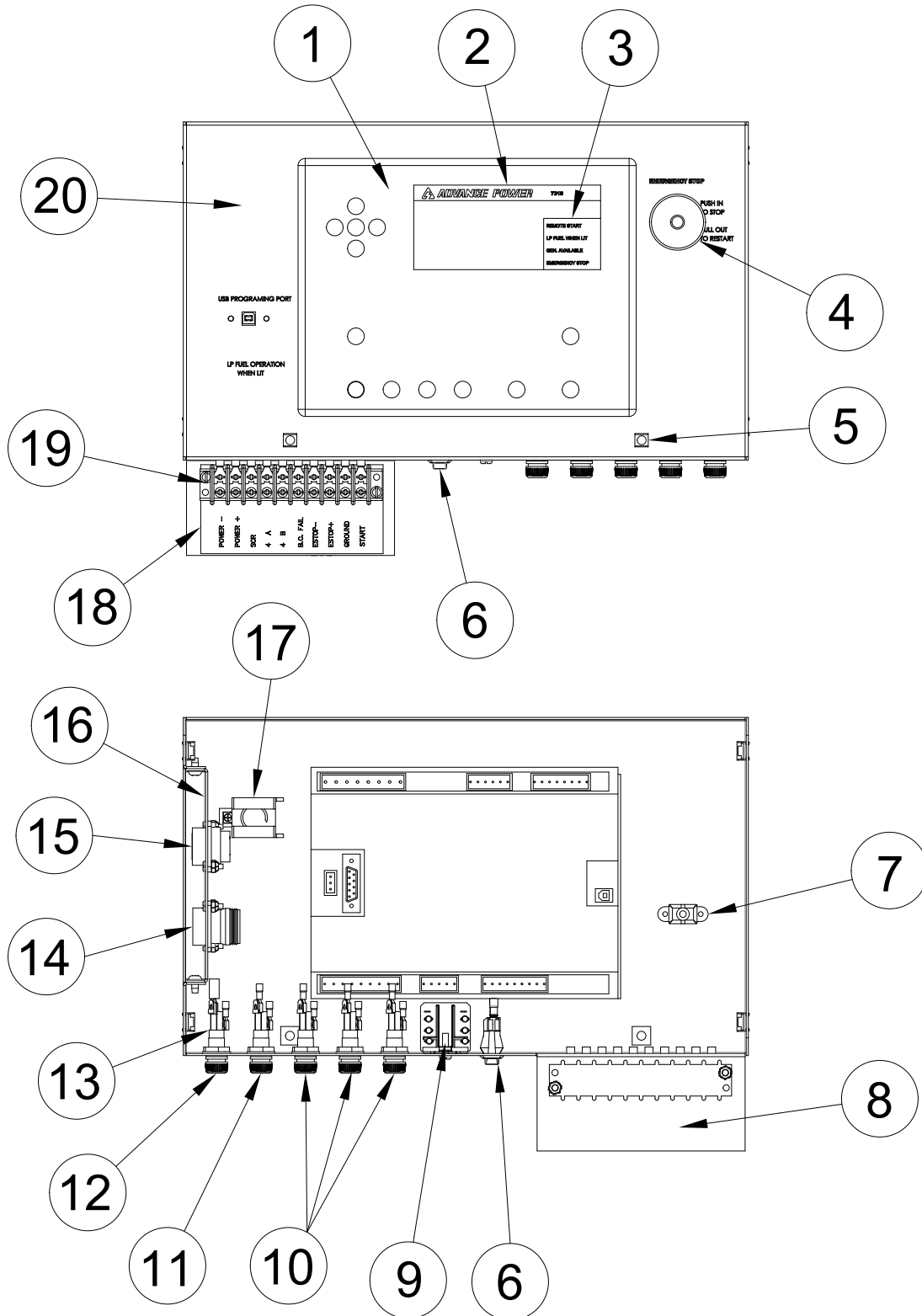

| REF # | PART NUMBER | QTY | DESCRIPTION |
|-------|-------------|-----|-------------------------|
| 1 | 351112-4 | 1 | DSE 7310 Controller |
| 2 | 1660-001 | 1 | Advance Power Insert |
| 3 | 16601-001 | 1 | LED Legend Insert |
| 4 | 99783-001 | 1 | Emergency Stop Switch |
| 5 | 92495-000 | 6 | Retainer Nut |
| 6 | 64089-000 | 1 | SPST Rocker Switch |
| 7 | 92844-005 | 1 | USB Cable |
| 8 | 99826-196 | 1 | DC Box |
| 9 | 59944-017 | 1 | DPDT Relay 12VDC 10 Amp |
| 10 | 95064-002 | 3 | 2 Amp Fuse |
| 11 | 95064-000 | 1 | 3 Amp Fuse |
| 12 | 95064-006 | 1 | 10 Amp Fuse |
| 13 | 2489-001 | 5 | Fuse Holder |
| 14 | 96925-006 | 1 | 16 Pin Connector |
| 15 | 96925-002 | 1 | 14 Pin Connector |
| 16 | 351900-11 | 1 | Connector Plate |
| 17 | 99783-002 | 1 | E Stop Contact |
| 18 | 64576-019 | 1 | Remote Terminal Decal |
| 19 | 80623-006 | 1 | 10 Point Terminal Block |
| 20 | 99055-038 | 1 | Control Panel |

DECALS

| REF # | PART NUMBER | QTY | DESCRIPTION |
|-------|-------------|-----|---------------------------|
| 1 | 97813-000 | 3 | Warning Auto Start Decal |
| 2 | 63941-001 | 1 | Hot Surface Decal |
| 3 | 15209-000 | 1 | UL Decal Set |
| 4 | 15209-100 | 1 | French UL Decal Set |
| 5 | 16502-001 | 1 | AC Disconnect Decal |
| 6 | 63941-003 | 1 | Battery Compartment Decal |
| 7 | 63941-005 | 1 | Receptacle Caution Decal |

CONTROL CABINET ASSEMBLY

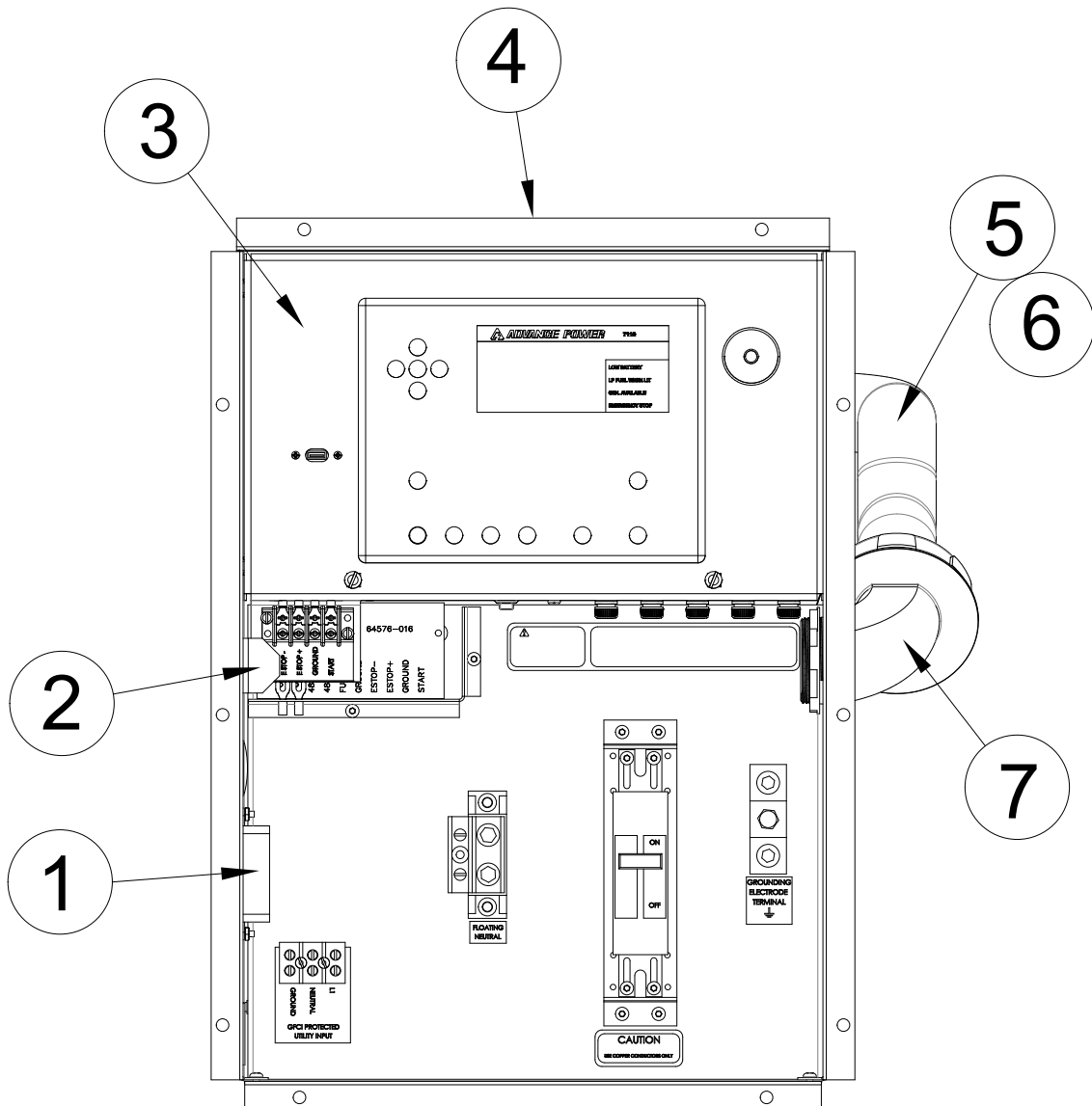

| REF # | PART NUMBER | QTY | DESCRIPTION |
|-------|-----------------|-----|-----------------------------|
| 1 | 24749-000 | 1 | Duplex Receptacle |
| 2 | 99826-194 | 1 | Door Latch |
| 3 | 99775-003 | 1 | DSE 7110 Control Assembly |
| 3 | 99775-000 | 1 | DSE 7310 Control Assembly |
| 4 | 99826-130 | 1 | Basler / Breaker Cabinet |
| 5 | 16522-000 | 1 | 2" Straight Conduit |
| 6 | 16523-001 | 22" | Flex Conduit |
| 7 | 16522-001 | 1 | 90° Conduit |
| NI | SEE TABLE | 1 | Circuit Breaker Cover Panel |
| NI | 54847-010 | 1 | 1-3/8" Hole Plug |
| NI | Not Illustrated | | |

| WINCO MODEL # | PART # |
|------------------------------|-----------|
| ULPSS30-3/C ULPSS30-3/D | 99826-230 |
| ULPSS30-4/C ULPSS30-4/D | 99826-231 |
| ULPSS30-17/C ULPSS30-17/D | 99826-232 |
| ULPSS30-18/C ULPSS30-18/D | 99826-233 |

CIRCUIT BREAKER ASSEMBLY

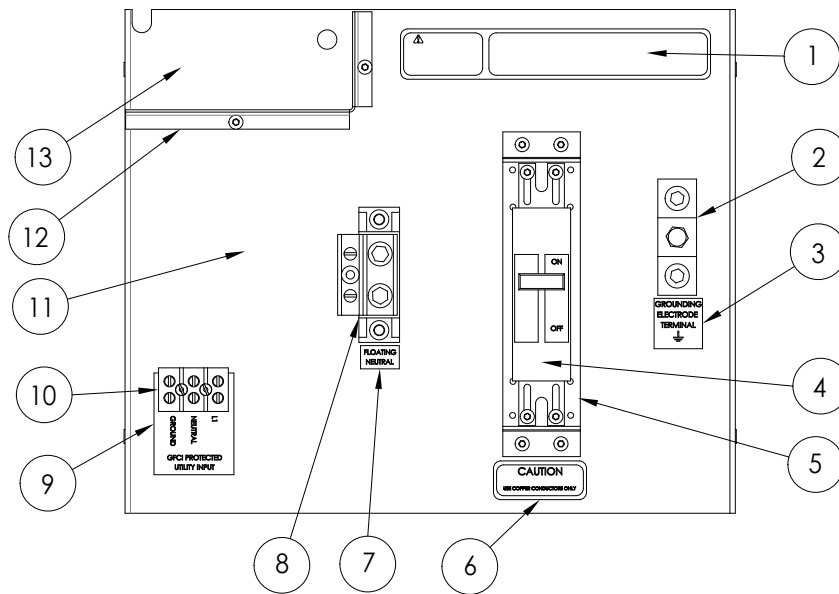

| REF # | PART NUMBER | QTY | DESCRIPTION |
|-------|-------------|-----|------------------------|
| 1 | 63941-007 | 1 | Fuse ID Warning Decal |
| 2 | 58060-000 | 2 | Ground Terminal Lug |
| 3 | 16499-000 | 1 | UL Grounding Decal |
| 4 | SEE TABLE | 1 | Circuit Breaker |
| 5 | SEE TABLE | 1 | CB Riser |
| 6 | 16503-000 | 1 | Copper Conductor Decal |
| 7 | 16501-000 | 1 | Floating Neutral Decal |
| 8 | 350124-4 | 1 | Neutral Lugs |
| 9 | 64576-006 | 1 | GFCI Protected Decal |
| 10 | 51795-000 | 1 | 3 Point Terminal Block |
| 11 | SEE TABLE | 1 | Circuit Breaker Panel |
| 12 | 99826-196 | 1 | DC Box |
| 13 | 64576-019 | 1 | Remote Terminal Decal |

| WINCO MODELS | PART NUMBER | DESCRIPTION |
|--------------|-------------|------------------------|
| ULPSS30-3/C | 92072-000 | CB RISER |
| ULPSS30-3/D | 58805-006 | 125 AMP 2-POLE BREAKER |
| | 92076-007 | CB PANEL |
| ULPSS30-4/C | 92072-001 | CB RISER |
| ULPSS30-4/D | 82584-004 | 100 AMP 3-POLE BREAKER |
| | 92076-008 | CB PANEL |
| ULPSS30-17/C | 92072-002 | CB RISER |
| ULPSS30-17/D | 82584-003 | 90 AMP 3-POLE BREAKER |
| | 92076-009 | CB PANEL |
| ULPSS30-18/C | 92072-003 | CB RISER |
| ULPSS30-18/D | 81097-002 | 45 AMP 3-POLE BREAKER |
| | 92076-010 | CB PANEL |

EXHAUST ASSEMBLY

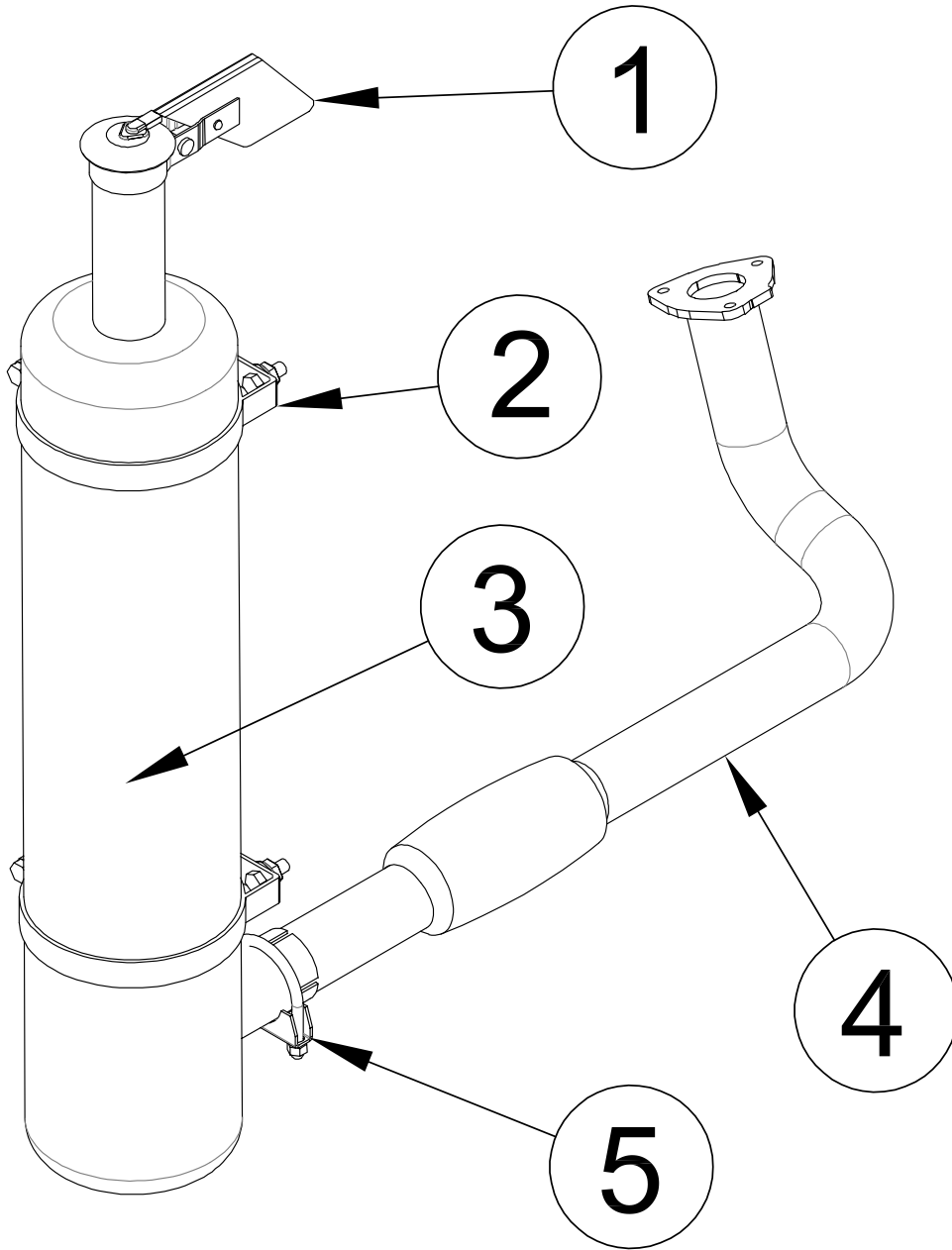

| REF # | PART NUMBER | QTY | DESCRIPTION |
|-------|-------------|-----|-----------------------|
| 1 | 53111-007 | 1 | 2" Rain Cap |
| 2 | 350264-2 | 2 | 6" Mounting Band |
| 3 | 80519-015 | 1 | Muffer |
| 4 | 99298-028 | 1 | Exhaust Flex w/Flange |
| 5 | 93489-011 | 1 | 2.25" Muffer Clamp |

VAPOR FUEL SYSTEM ASSEMBLY

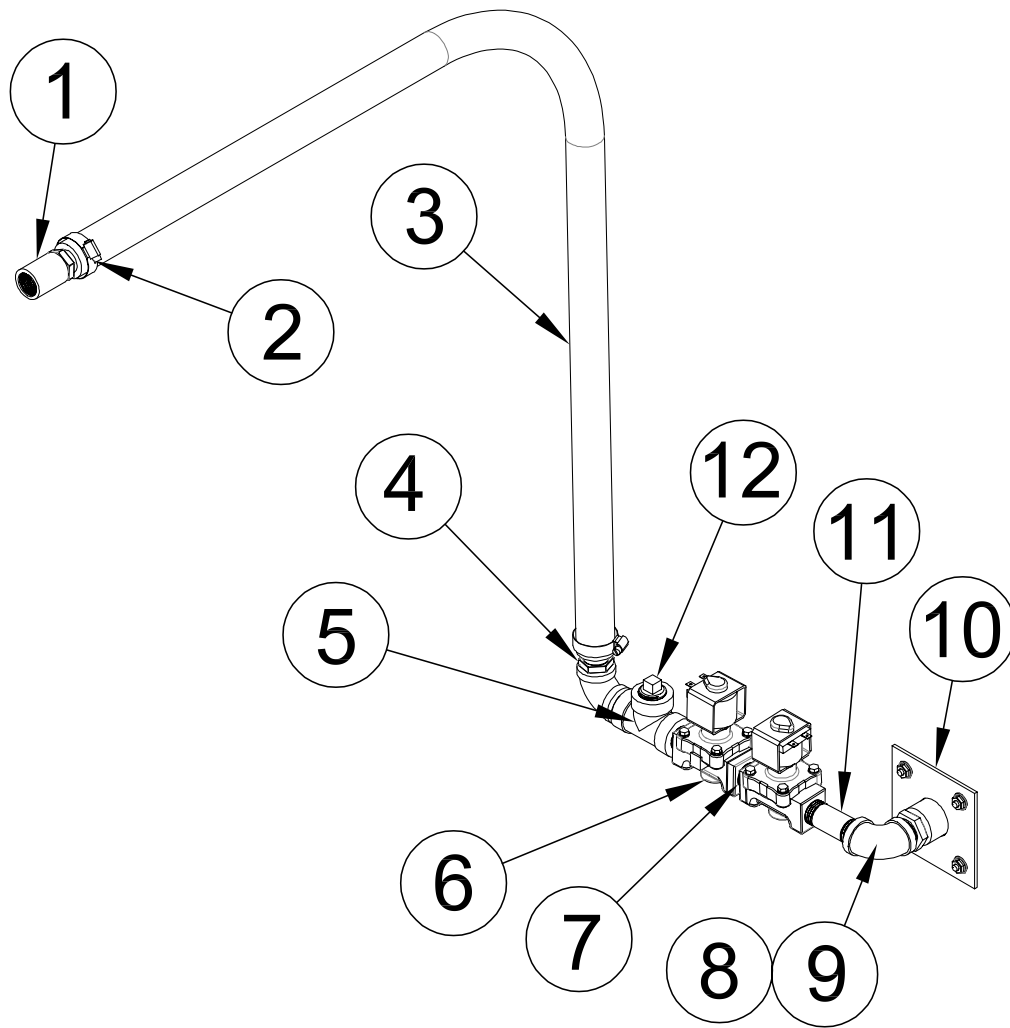

| REF # | PART NUMBER | QTY | DESCRIPTION |
|-------|-------------|-----|------------------------|
| 1 | 22766-000 | 1 | 3/4" Pipe Coupling |
| 2 | 81018-004 | 2 | Hose Clamp |
| 3 | 49409-012 | 56" | 1" I.D. Hose |
| 4 | 92388-004 | 2 | 3/4" X 1" Hose Fitting |
| 5 | 94907-000 | 1 | Tee Fitting |
| 6 | 42942-000 | 2 | Solenoid |
| 7 | 54074-006 | 4 | 1-1/2" Pipe Nipple |
| 8 | 50244-000 | 2 | 90° Pipe Elbow |
| 9 | 81077-000 | 1 | 1" X 3/4" Reducer |
| 10 | 99065-000 | 1 | Fuel Inlet Weldment |
| 11 | 54074-001 | 1 | 3-1/2" Pipe Nipple |
| 12 | 93564-000 | 1 | Pipe Plug |

LP LIQUID WITHDRAWAL ASSEMBLY

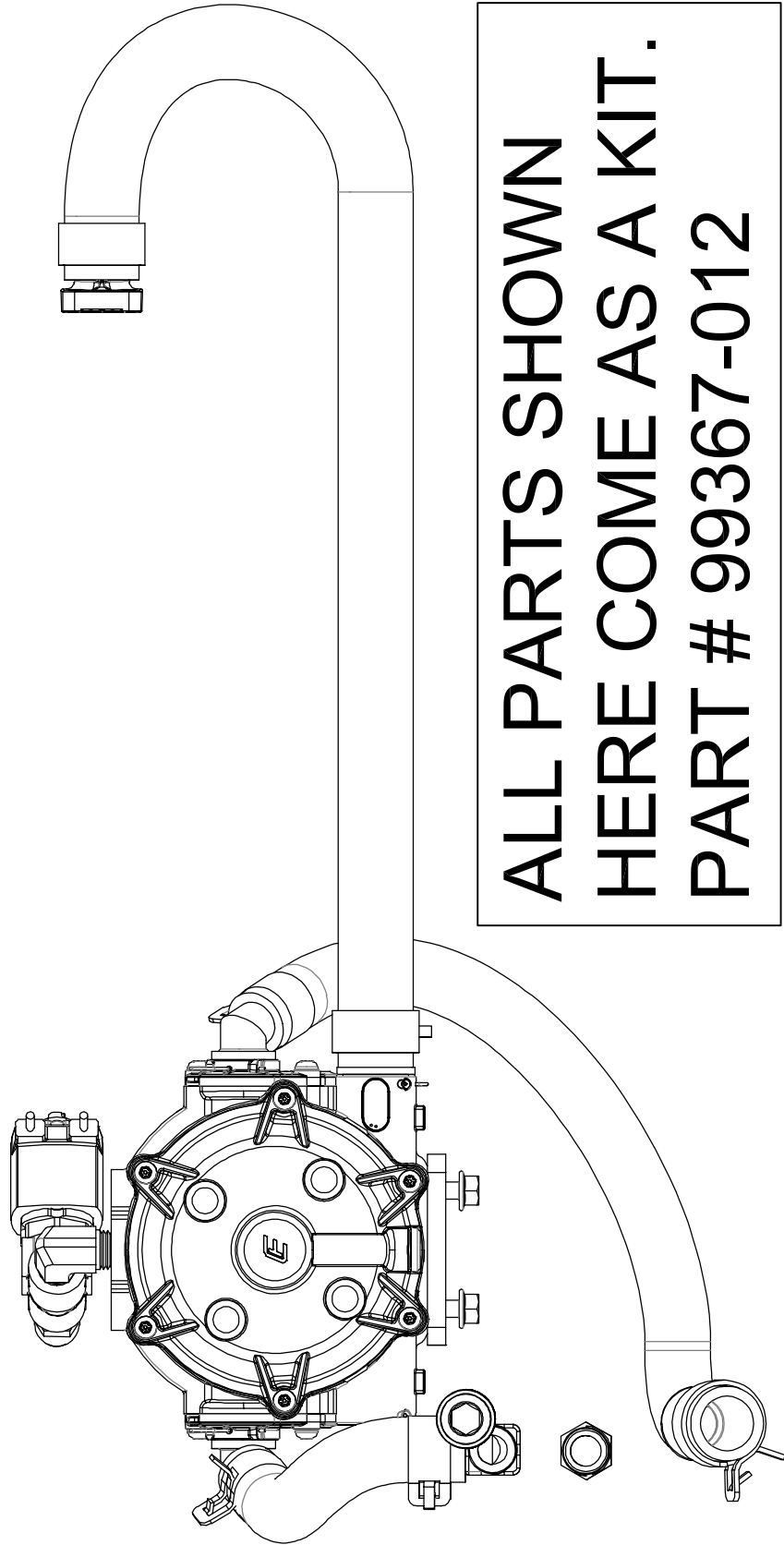

AC WIRING MODIFICATIONS

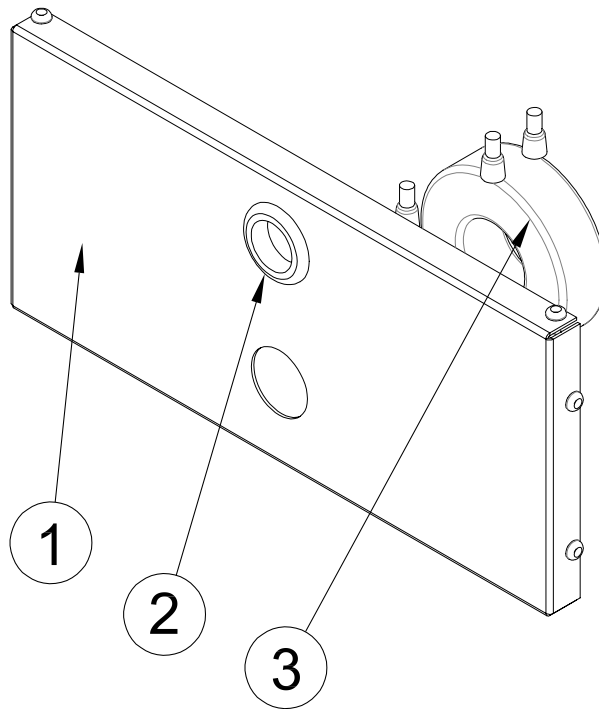

| REF # | PART NUMBER | QTY | DESCRIPTION |
|-------|-----------------|--------|-----------------------|
| 1 | 64702-003 | 1 | Generator Front Panel |
| 2 | 62486-000 | 1 | Grommet |
| 3 | SEE TABLE | 2 or 3 | Current Transformer |
| NI | SEE TABLE | 1 | AC Wiring Harness |
| NI | Not Illustrated | | |

| MODEL # | PART # | QTY | DESCRIPTION |
|---|-----------|-----|--|
| ULPSS30-3/C ULPSS30-3/D | 80124-004 | 2 | 150 to 5 Amp Current Transformer |
| ULPSS30-4/C & D ULPSS30-17/C & D ULPSS30-18/C & D | 80124-004 | 3 | 150 to 5 Amp Current Transformer |

| MODEL # | PART # | QTY | DESCRIPTION |
|---|-----------|-----|-------------|
| ULPSS30-3/C ULPSS30-3/D | 99347-014 | 1 | AC Harness |
| ULPSS30-4/C & D ULPSS30-17/C & D ULPSS30-18/C & D | 99347-015 | 1 | AC Harness |

HOUSING ASSEMBLY

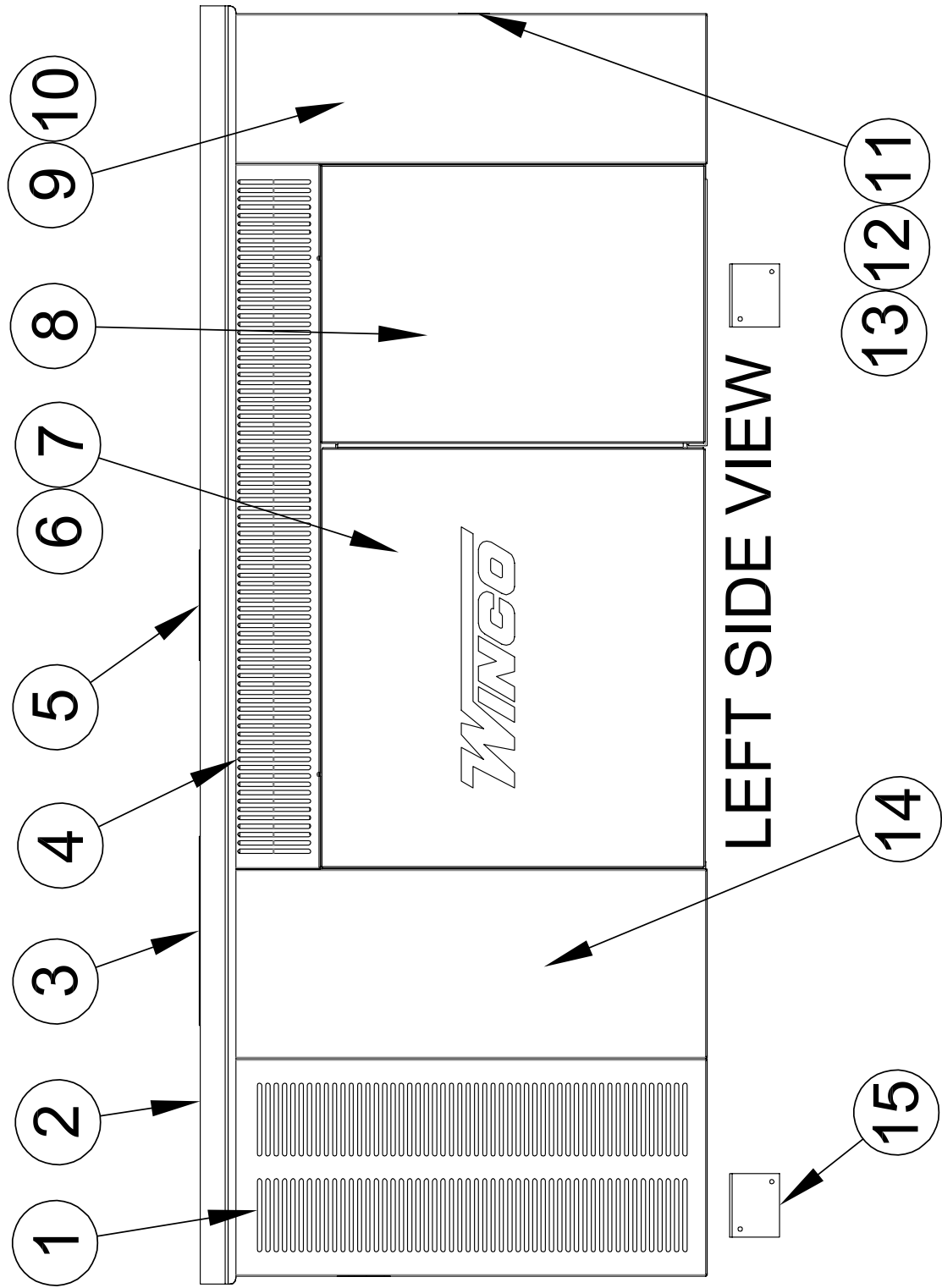

| REF # | PART NUMBER | QTY | DESCRIPTION |
|-------|-----------------|-------|----------------------------|
| 1 | 99071-040 | 1 | Front Housing |
| 2 | 99515-030 | 1 | Roof |
| 3 | 99515-013 | 1 | Roof Access, Radiator |
| 4 | 99078-032 | 1 | Left Side Sill |
| 5 | 99515-011 | 1 | Oil Level Access Cover |
| 6 | 99100-038 | 1 | Left Side Panel |
| 7 | 99378-135 | 1 | Left Side Sill Baffle |
| 8 | 99100-039 | 1 | Rear Side Panel |
| 9 | 99067-031 | 1 | Left Rear Corner |
| 10 | 99378-132 | 1 | Left Rear Baffle |
| 11 | 99100-033 | 1 | Rear Center Panel |
| 12 | 99100-032 | 1 | Rear Sill |
| 13 | 99378-130 | 1 | Rear Sill Baffle |
| 14 | 99071-039 | 1 | Radiator Housing |
| 15 | 99060-000 | 4 | Frame Cover Plate |
| NI | 99078-033 | 1 | Right Side Sill |
| NI | 99378-136 | 1 | Right Side Sill Baffle |
| NI | 99067-032 | 1 | Right Rear Corner |
| NI | 99378-131 | 1 | Right Rear Baffle |
| NI | 99100-037 | 1 | Right Side Panel |
| NI | 15680-058 | 1 | PSS 30 Door |
| NI | 99333-018 | 1 | Door Stop |
| NI | 99225-006 | 2 | Roof Support |
| NI | 91683-000 | 10 | ¼ Turn Clip Nut Receptacle |
| NI | 91682-002 | 10 | ¼ Turn Bail Style Stud |
| NI | 91684-000 | 10 | ¼ Turn Split Ring Retainer |
| NI | 65000-003 | 8 | Thumb Screw |
| NI | 92421-000 | 12 FT | 1.5" X 1.5" Foam Strip |
| NI | 62912-000 | 15 FT | ½" Wide Foam Strip |
| NI | 62912-002 | 6 FT | ¾" Wide Foam Strip |
| NI | 95229--005 | 1 | Door Latch |
| NI | 98375-031 | 1 | Door Hinge |
| NI | Not Illustrated | | |

FOAM PIECES

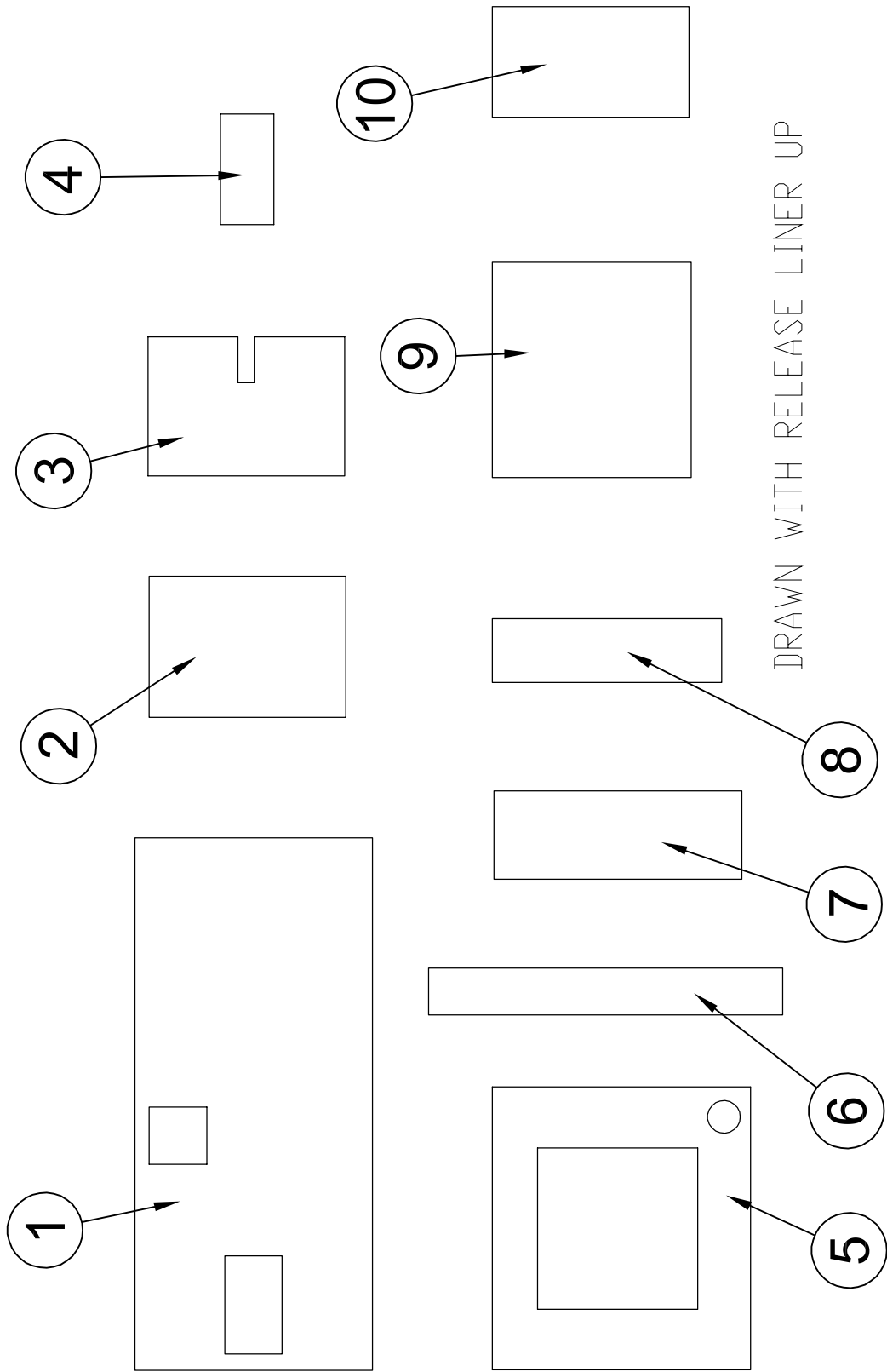

| REF # | PART NUMBER | QTY | DESCRIPTION |
|-------|-------------|-----|-----------------------|
| 1 | 99393-441 | 1 | Roof Foam |
| 2 | 99393-436 | 1 | Rear Side Panel Foam |
| 3 | 99393-437 | 1 | Door Foam |
| 4 | 99393-439 | 1 | Rear Sill Foam |
| 5 | 99393-432 | 1 | Radiator Housing Foam |
| 6 | 99393-434 | 2 | Side Sill Foam |
| 7 | 99393-433 | 2 | Radiator Housing Side |
| 8 | 99393-438 | 2 | Rear Baffle Foam |
| 9 | 99393-435 | 2 | Side Panel Foam |
| 10 | 99393-440 | 1 | Rear Panel Foam |

BLOCK HEATER ASSEMBLY

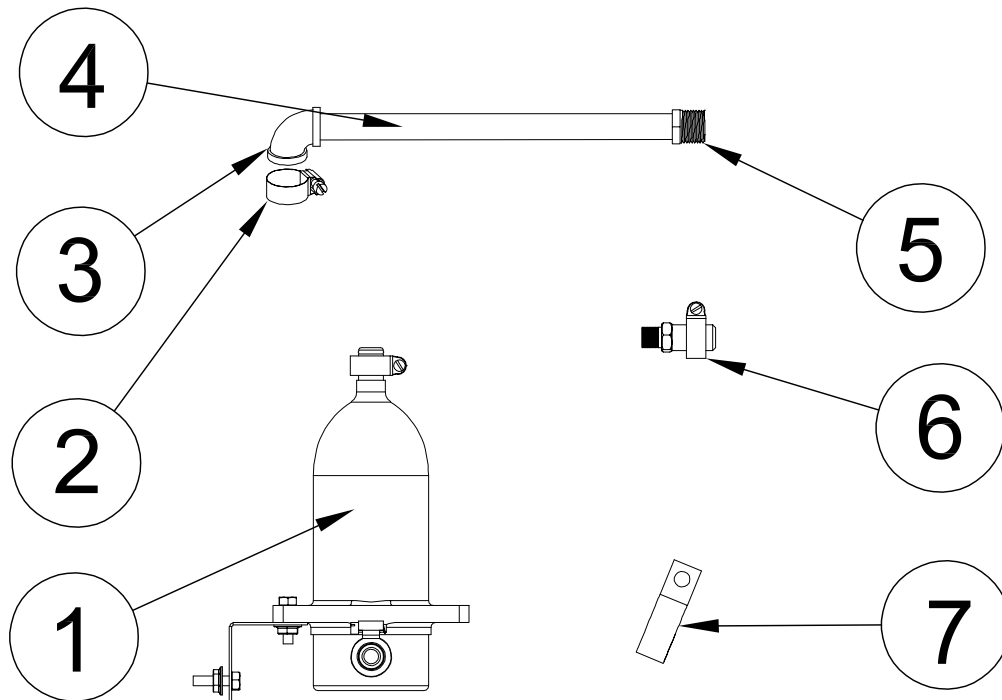

| REF # | PART NUMBER | QTY | DESCRIPTION |
|-------|-----------------|------|--------------------------|
| 1 | 80781-003 | 1 | 1000W 120V Tank Heater |
| 2 | 81018-005 | 4 | Hose Clamp |
| 3 | 53196-000 | 1 | 3/8" Pipe Elbow |
| 4 | 16456-012 | 1 | 3/8" X 10" Pipe Nipple |
| 5 | 56372-000 | 1 | Reducer |
| 6 | 350341 | 1 | Hose Fitting |
| 7 | 97391-008 | 1 | Tube Clamp |
| NI | 93689-001 | 8 FT | 5/8" Hose |
| NI | 92388-000 | 1 | 3/8" X 5/8" Hose Fitting |
| NI | Not Illustrated | | |

ULPSS30-3/C & D

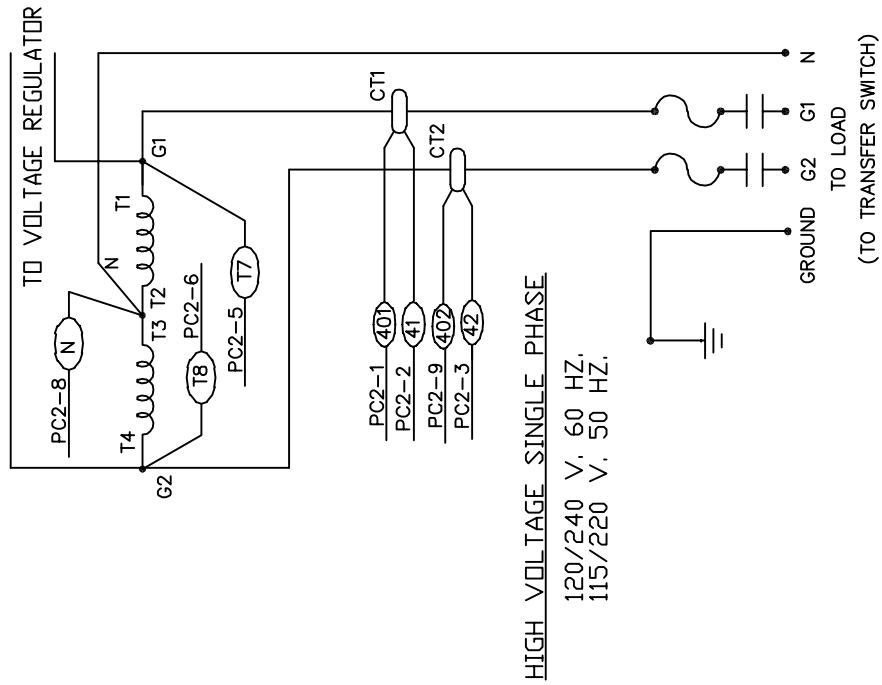

AC WIRING SCHEMATICS

ULPSS30-18/C & D

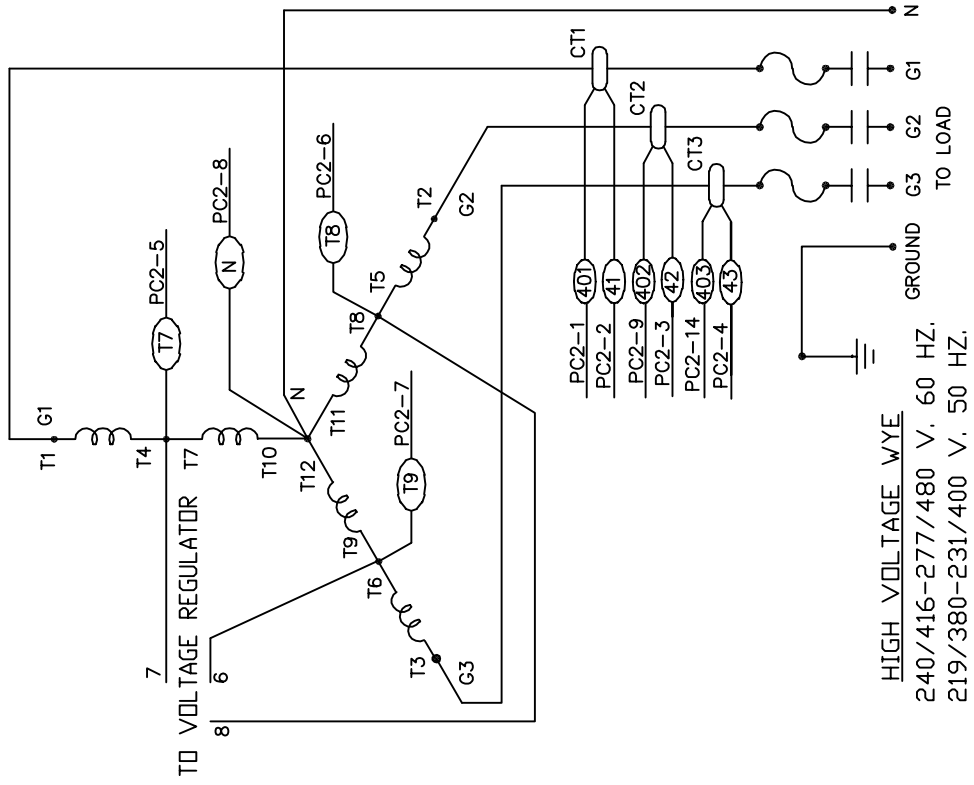

ULPSS30-4/C & D

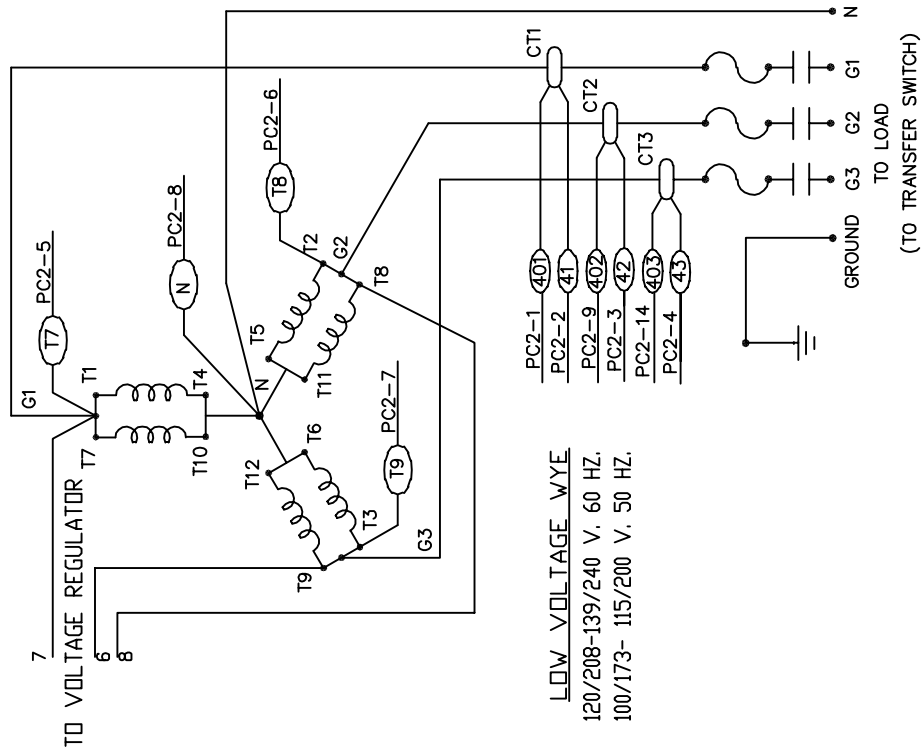

ULPSS30-17/C & D

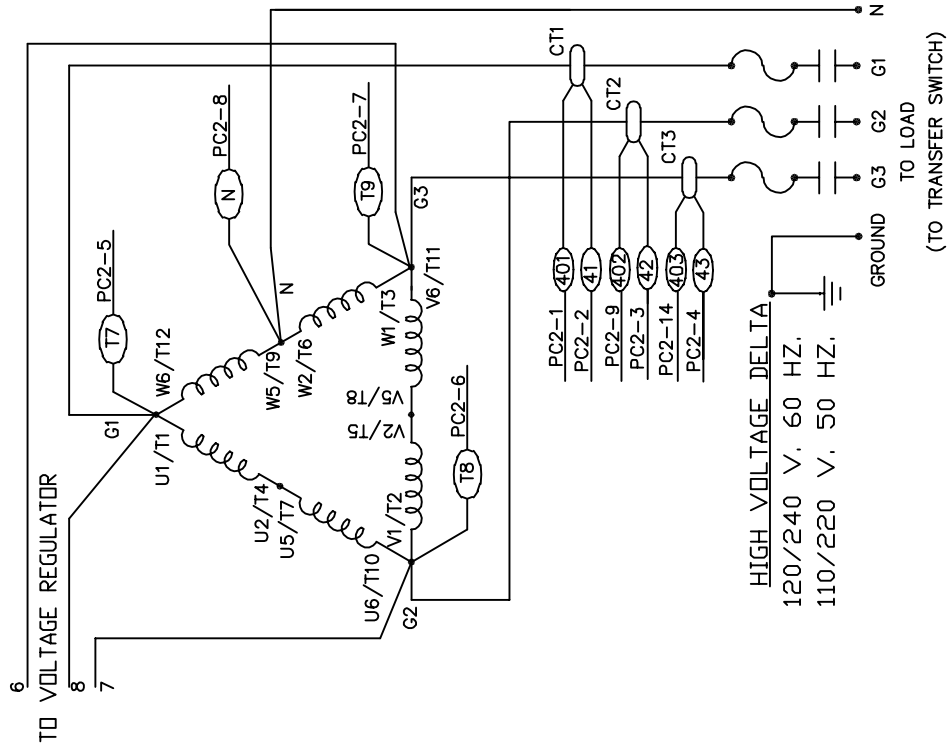

AC WIRING SCHEMATICS

DC WIRING SCHEMATIC DSE7110

TO A.C. POWER GENERATOR

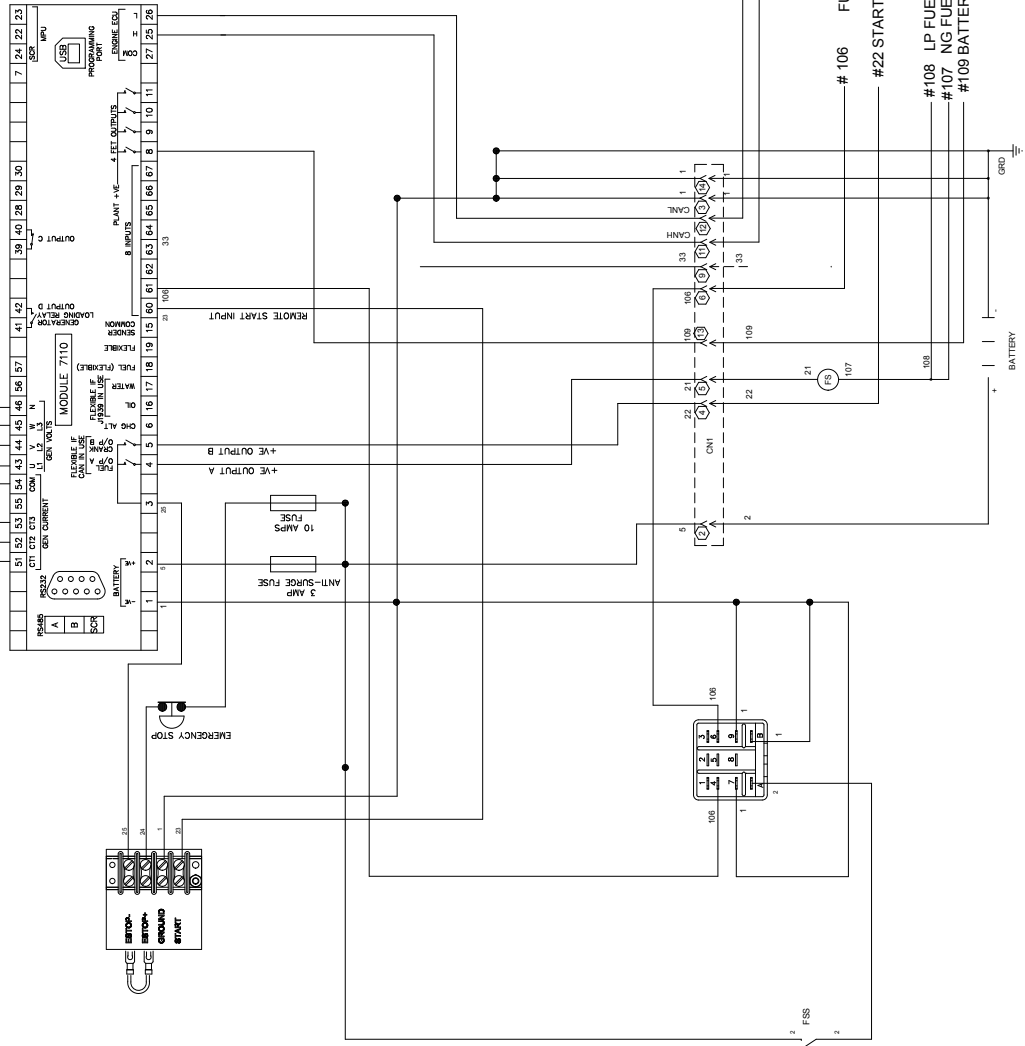
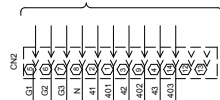

LEGEND

- CN1 16 PIN (LARGE CONNECTOR)
- ENGINE CONTROL HARNESS
- CN2 14 PIN GENERATOR HARNESS
- AC CONTROL HARNESS
- CANH CANBUS HIGH
- CANL CANBUS LOW
- ESS EMERGENCY STOP SWITCH
- GRD GROUND (CHASSIS OR FRAME)
- LCL OPTIONAL LOW COOLANT LEVEL PROBE
- FS FUEL SOLENOIDS
- FSS FUEL SELECT SWITCH

- GROUND
- AUX PWN 5
- CAN -
- CAN +
- AUX ANA PUD 1
- GOV 1
- AUX ANA PUD3
- AUX ANA PUD.2
- FUEL SELECT
- MIL
- START COMMAND
- AUX PWN 4
- RELAY POWER
- LOCKOFF (SECONDARY)
- LOCKOFF (PRIMARY)
- VSW

- #1 BAT NEG
- CANL
- CANH
- NOT USED
- NOT USED
- NOT USED
- NOT USED
- FUEL SELECT
- NOT USED
- #22 START COMMAND
- NOT USED
- NOT USED
- #108 LP FUEL SOLENOID
- #107 NG FUEL SOLENOID
- #109 BATTERY POSITIVE

DC WIRING SCHEMATIC DSE7310

