

ILLUSTRATED PARTS LIST

PSS30-3/A

PSS30-4/A

PSS30-17/A

PSS30-18/A

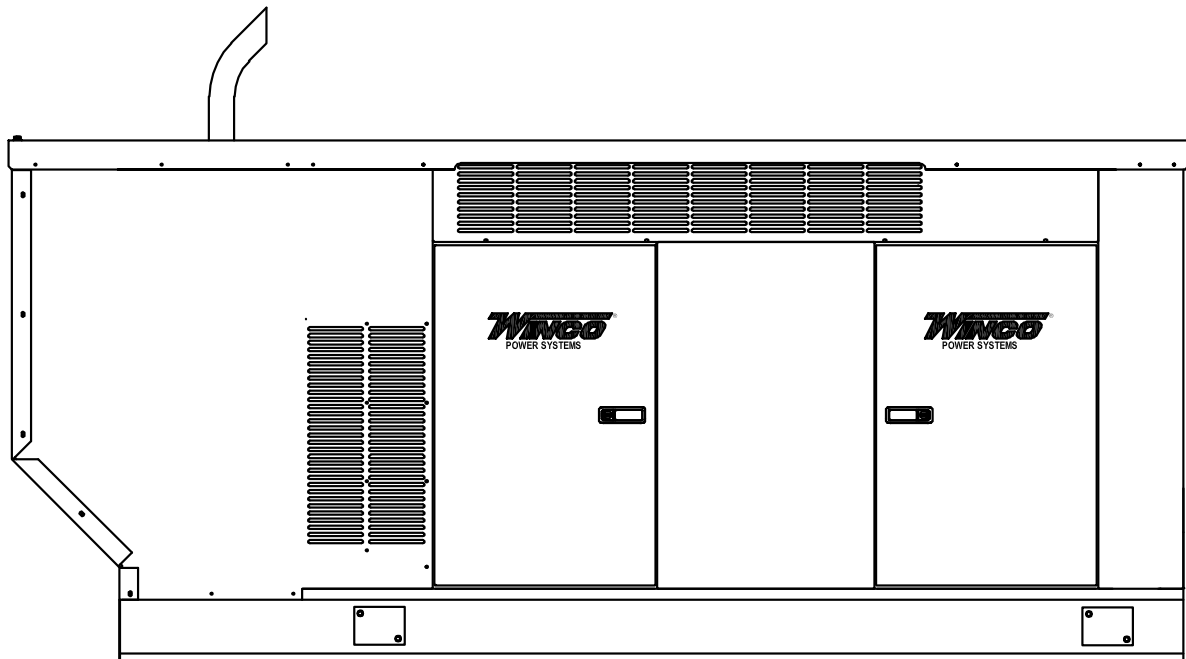

ENGINE & GENERATOR ASSEMBLY

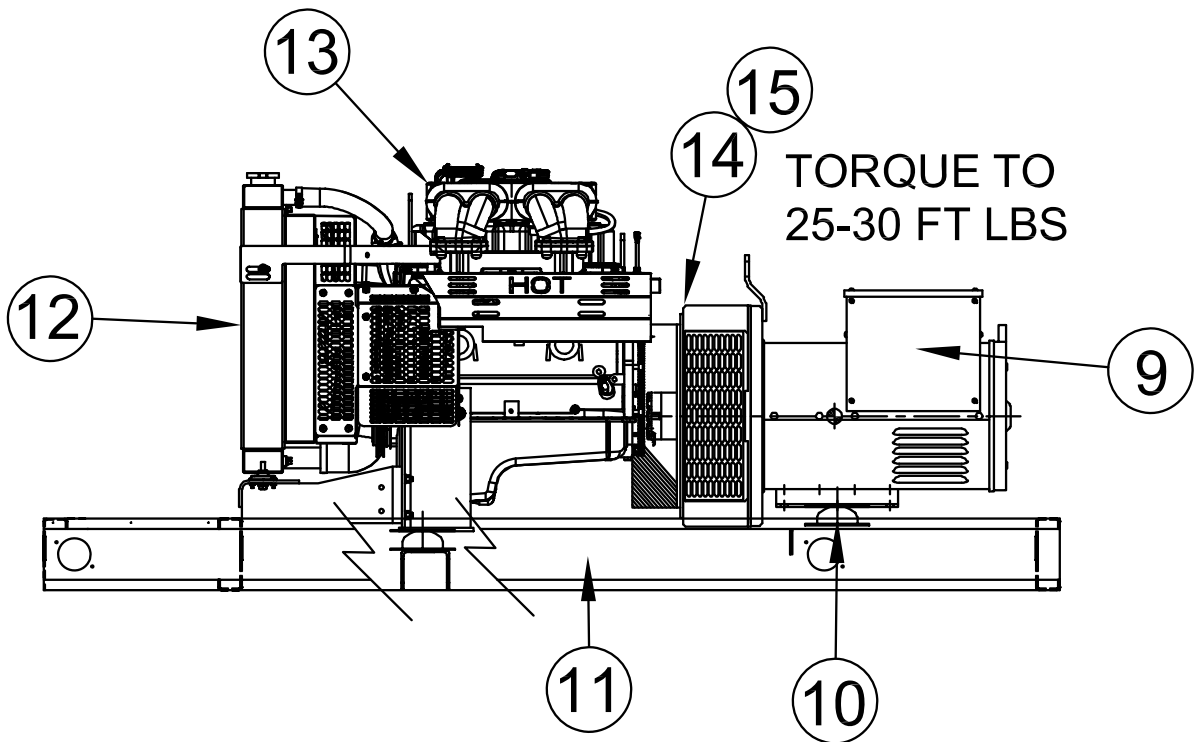
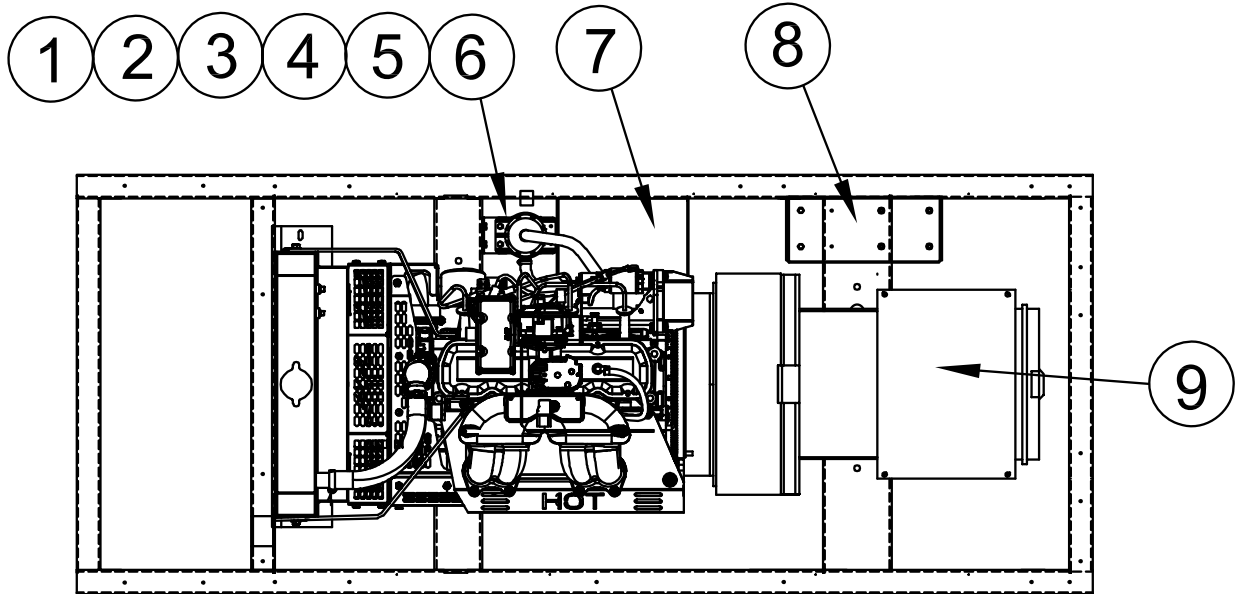

| REF # | PART NUMBER | QTY | DESCRIPTION |
|-------|-------------|-----|-----------------------------|
| 1 | 80781-003 | 1 | Tank Heater 1000W |
| 2 | 92388-000 | 1 | Hose Fitting 3/8" X 5/8" |
| 3 | 81018-008 | 4 | Hose Clamp |
| 4 | 56372-000 | 1 | Reducer Bushing 1/2" X 3/8" |
| 5 | 350341 | 1 | Hose Fitting 1/4" X 5/8" |

| REF # | PART NUMBER | QTY | DESCRIPTION |
|-------|------------------------------|-----------|----------------------------|
| 6 | 64893-003 | 1 | Block Heater Bracket |
| 7 | 99317-001 | 1 | Battery Tray |
| 8 | 99057-018 | 1 | Support Pedestal |
| 9 | SEE TABLE | 1 | Generator |
| 10 | 98956-001 | 4 | Shock Mount |
| 11 | 99381-021 | 1 | Base Assembly |
| 12 | Reference | 1* | Radiator |
| 13 | 351987-1 | 1 | Engine GM 3.0 L |
| 14 | 481-000 | 12 | Lock Washer 3/8" |
| 15 | 96000-004 | 12 | HHCS 3/8"-16 X 1 1/2" |
| NI | 53220-067 | 1 | Negative (-) Battery Cable |
| NI | 53220-056 | 1 | Positive (+) Battery Cable |
| NI | 93542-010 | 2 | Lead Wire Assembly |
| NI | Reference | 1* | Temperature Sender |
| NI | Reference | 1* | Oil Pressure Sender |
| NI | 350818-2 | 1 | Voltage Regulator AS440UL |
| NI | 80124-008 | 2 or 3*** | Current Transformer 500:5 |
| NI | PF454 | 1** | Oil Filter |
| NI | 97294-003 | 1 | Air Filter Assembly |
| NI | R42LTS or R44LTS | 4** | Impco AF1-15 |
| NI | Not Illustrated | | Spark Plug |
| * | Parts provided by GM | | |
| ** | AC Delco part # | | |
| *** | 2 for 1 Phase; 3 for 3 Phase | | |

| STAMFORD NEWAGE MODEL # | BCI184G1J 4-LEAD | BCI184H1L 12-LEAD |
|-------------------------------|---------------------------|---|
| WINCO PART # | 351965-31 | 351965-4 |
| WINCO MODEL #'S | PSS30-3/A PSS30-3/ALPG | PSS30-4/A PSS30-4/ALPG PSS30-17/A PSS30-17/ALPG PSS30-18/A PSS30-18/ALPG |

FUEL SYSTEM ASSEMBLY

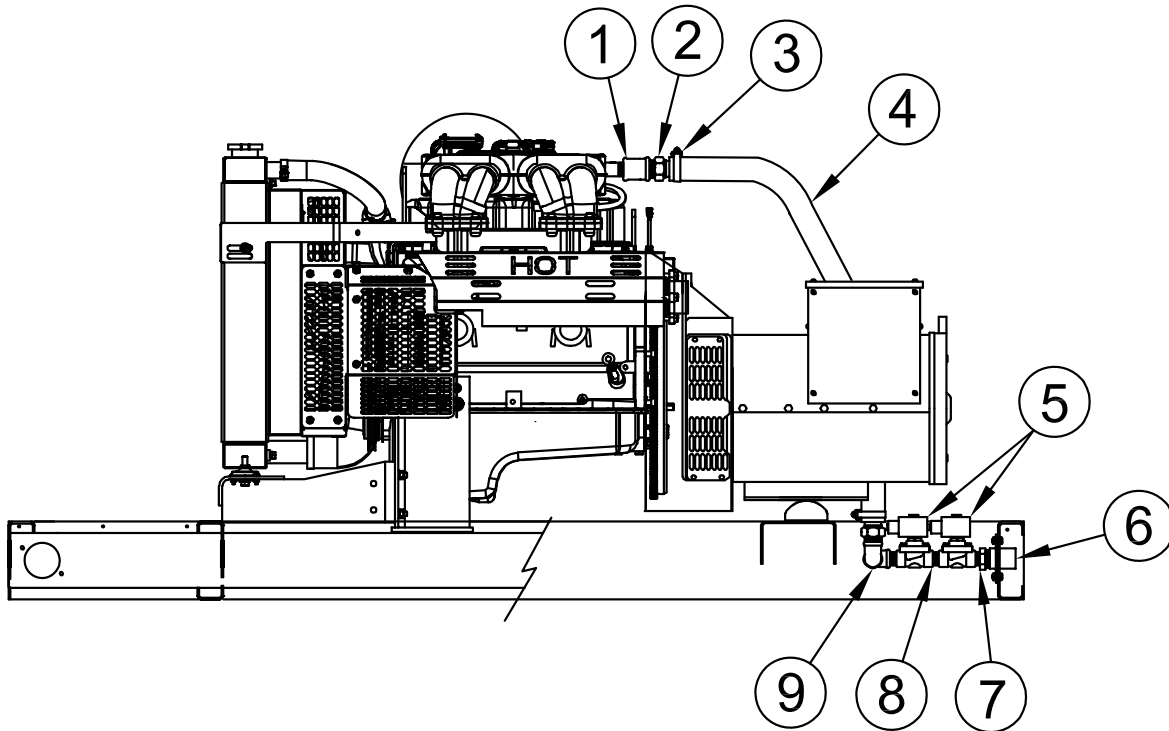

| REF # | PART NUMBER | QTY | DESCRIPTION |
|-------|-------------|-----|-------------------------|
| 1 | 22766-000 | 1 | 3/4" Pipe Coupling |
| 2 | 92388-004 | 2 | 3/4" X 1" Hose Fitting |
| 3 | 81018-004 | 2 | Hose Clamp |
| 4 | 49409-007 | 1 | 1" I.D. Hose (47" long) |
| 5 | 42942-000 | 2 | Fuel Solenoid |
| 6 | 99065-000 | 1 | Fuel Inlet Weldment |
| 7 | 81077-000 | 1 | 1" X 3/4" Pipe Reducer |
| 8 | 54074-006 | 4 | 3/4" 1-1/2" Pipe Nipple |
| 9 | 50244-000 | 2 | 3/4" X 90° Pipe Elbow |

WINCO INC.
A Division of DTE Dyna Technology Inc

WINCO INC.
225 S. CORDOVA AVE.
LECENTER, MN 56057
507-357-6821
SERVICE DEPT.
507-357-6831

EXHAUST SYSTEM ASSEMBLY

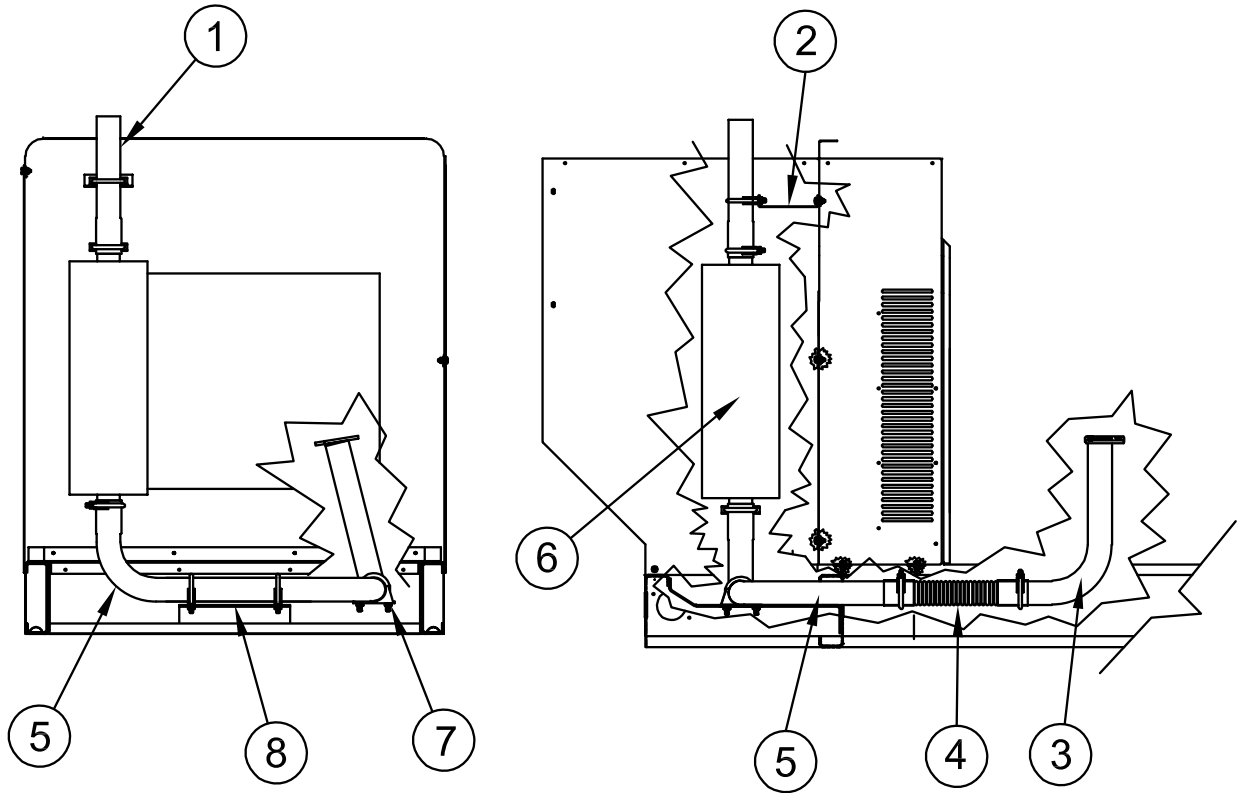

| REF # | PART NUMBER | QTY | DESCRIPTION |
|-------|-------------|-----|--------------------------|
| 1 | 99298-012 | 1 | Tail Pipe |
| 2 | 99234-001 | 1 | Exhaust Pipe Support |
| 3 | 99298-011 | 1 | Exhaust Pipe with Flange |
| 4 | 64743-001 | 1 | Flex Exhaust |
| 5 | 99298-010 | 1 | Exhaust Pipe |
| 6 | 80519-001 | 1 | Muffler |
| 7 | 93489-003 | 7 | Muffler Clamp |
| 8 | 99291-005 | 1 | Exhaust Support |

HOUSING ASSEMBLY

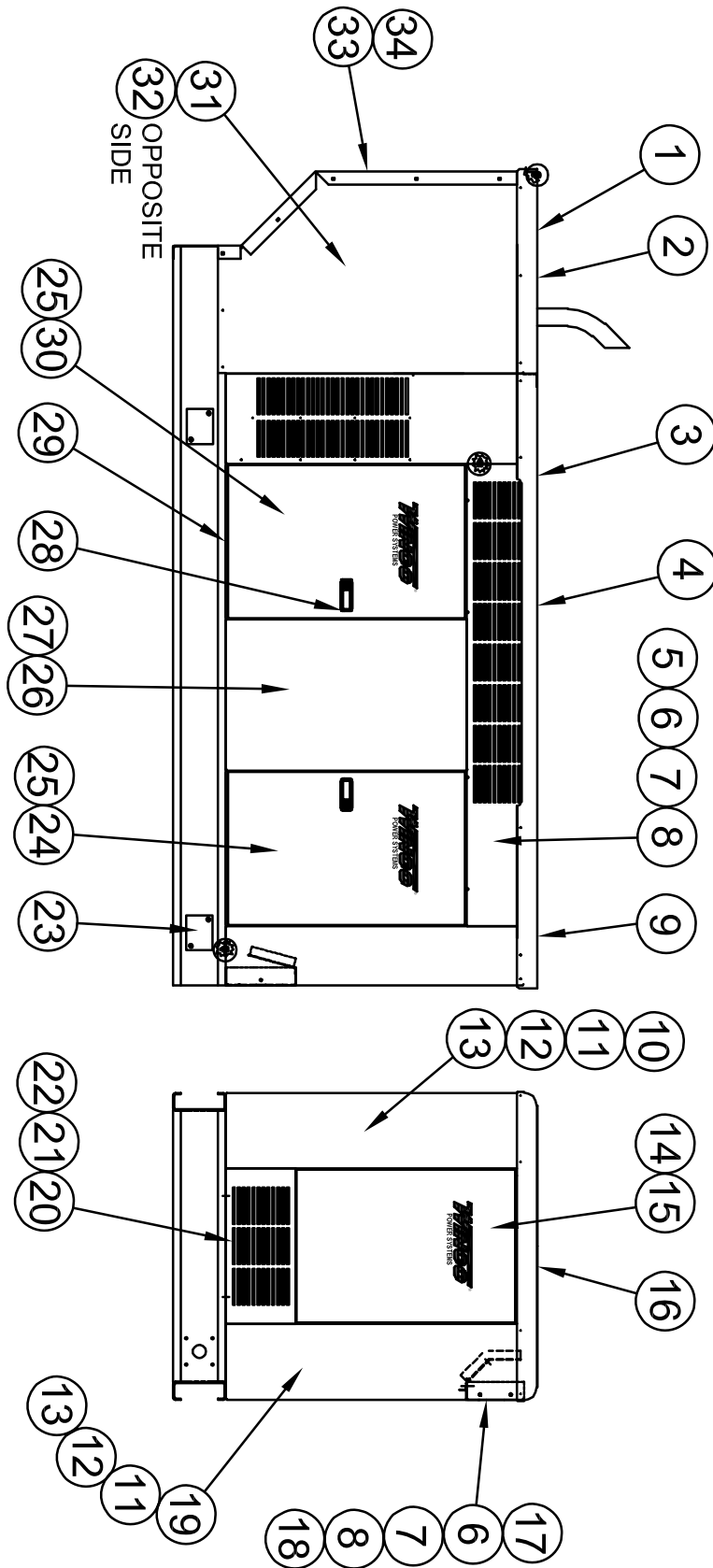

| REF # | PART NUMBER | QTY | DESCRIPTION |
|-------|-----------------|-----|-----------------------------|
| 1 | 99086-012 | 1 | Roof |
| 2 | 99393-419 | 1 | Foam Part Roof Front |
| 3 | 62026-003 | 1 | Radiator Cap Cover Plate |
| 4 | 99225-001 | 1 | Roof Support |
| 5 | 99098-003 | 1 | Side Sill |
| 6 | 99103-005 | 1 | Side Sill Backing Plate |
| 7 | 99224-000 | 2 | Door Jam |
| 8 | 99393-432 | 4 | Foam Parts L & R Sill |
| 9 | 99393-434 | 1 | Foam Part Roof Rear |
| 10 | 99067-013 | 1 | Left Rear Corner Post |
| 11 | 98375-016 | 2 | Hinge |
| 12 | 99393-435 | 2 | Foam Part Side |
| 13 | 99393-410 | 2 | Foam Part End |
| 14 | 15680-028 | 1 | Rear Door |
| 15 | 99393-423 | 1 | Foam Part Rear Door |
| 16 | 99391-002 | 1 | Roof End |
| 17 | 99098-004 | 1 | Side Sill |
| 18 | 99224-001 | 1 | Door Jam |
| 19 | 99067-014 | 1 | Right Rear Corner Post |
| 20 | 99100-000 | 1 | Rear Door Bottom Sill |
| 21 | 99103-000 | 1 | Bottom Sill Backing Plate |
| 22 | 99393-404 | 1 | Foam Part Rear Door Sill |
| 23 | 99060-000 | 4 | Lifting Hole Cover Plate |
| 24 | 15680-030 | 2 | Left Swing Door |
| 25 | 99393-424 | 3 | Foam Part Left Door |
| 26 | 99066-004 | 1 | Mullion |
| 27 | 99393-431 | 1 | Foam Part Mullion |
| 28 | 95299-005 | 4 | Door Latch |
| 29 | 99333-404 | 3 | Bottom Door Stop |
| 30 | 15680-029 | 1 | Right Swing Door |
| 31 | 99392-008 | 1 | Left Side Extension Panel |
| 32 | 99383-009 | 1 | Right Side Extension Panel |
| 33 | 99083-001 | 1 | Front Extension Panel Cover |
| 34 | 99393-406 | 1 | Foam Part Panel Cover |
| NI | 99393-418 | 1 | Foam Part Housing Front |
| NI | 15680-435 | 1 | Wider Right Swing Door |
| NI | 99393-436 | 1 | Foam Part |
| NI | 99066-405 | 1 | Right Side Mullion |
| NI | 99393-437 | 1 | Foam Part Mullion |
| NI | 99333-406 | 1 | Bottom Door Stop |
| NI | Not Illustrated | | |

CIRCUIT BREAKER ASSEMBLY

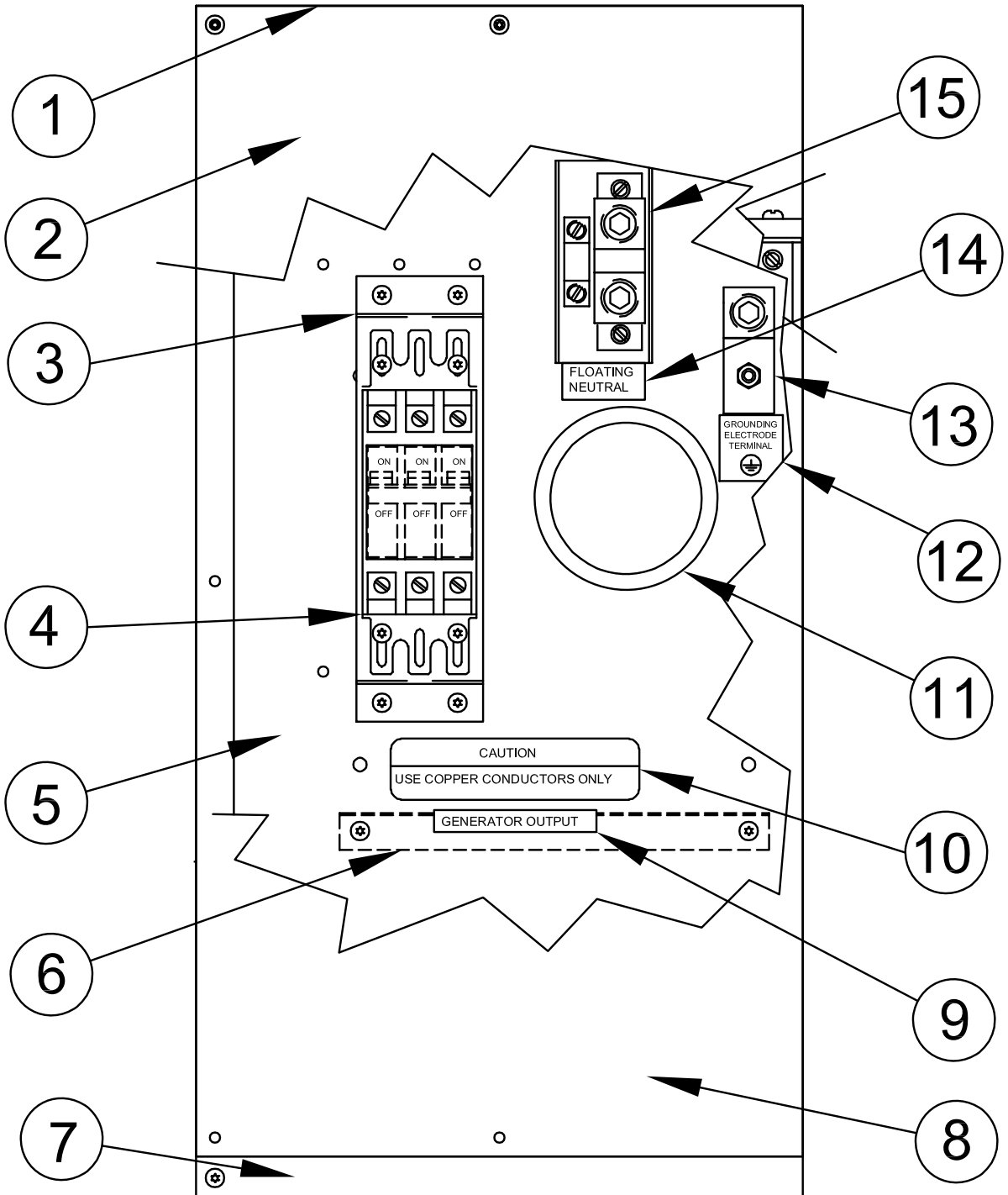

| REF # | PART NUMBER | QTY | DESCRIPTION |
|-------|-------------|--------|---------------------------|
| 1 | 99828-005 | 1 | Cabinet Top Panel |
| 2 | 99827-009 | 1 | Cabinet Cover Plate |
| 3 | 99831-004 | 1 | Circuit Breaker Spacer |
| 4 | SEE TABLE | 1 | Circuit Breaker |
| 5 | 99826-004 | 1 | Cabinet Back & Sides |
| 6 | 61294-011 | 1 | Angle Bracket |
| 7 | 99828-004 | 1 | Cabinet Bottom Panel |
| 8 | 99731-018 | 1 | Cover Panel |
| 9 | 64576-009 | 1 | Generator Output Decal |
| 10 | 16503-000 | 1 | Copper Connector Decal |
| 11 | 58684-000 | .83 FT | Continuous Grommet |
| 12 | 16499-001 | 1 | Grounding Electrode Decal |
| 13 | 58060-000 | 1 | Pressure Type Terminal |
| 14 | 16501-000 | 1 | Floating Neutral Decal |
| 15 | 350124-3 | 1 | Neutral Terminal |

| MODEL | PART NUMBER | DESCRIPTION |
|------------|-------------|---------------------|
| PSS30-3/A | 58805-006 | 125A 2 POLE BREAKER |
| PSS30-4/A | 82584-004 | 100A 3 POLE BREAKER |
| PSS30-17/A | 82584-003 | 90A 3 POLE BREAKER |
| PSS30-18/A | 81097-021 | 45A 3 POLE BREAKER |

BATTERY TENDER ASSEMBLY

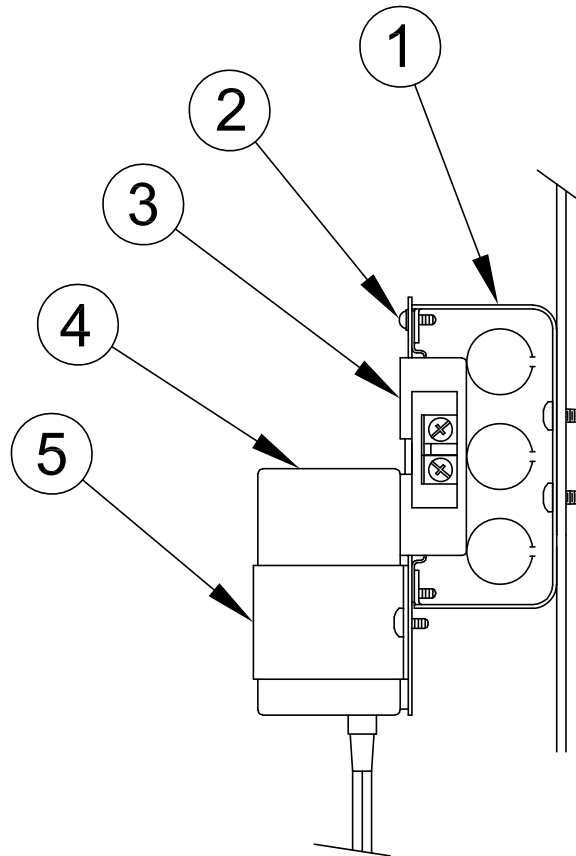

| REF # | PART NUMBER | QTY | DESCRIPTION |
|-------|-----------------|-----|--------------------------|
| 1 | 92789-000 | 1 | 2" x 2" x 4" Utility Box |
| 2 | 59026-002 | 1 | Receptacle Cover Plate |
| 3 | 24749-000 | 1 | Duplex Receptacle |
| 4 | 16287-000 | 1 | Battery Tender |
| 5 | 300308-410 | 1 | Hold Down Bracket |
| NI | 63941-005 | 1 | Receptacle Caution Decal |
| NI | Not Illustrated | | |

HOUSING FRONT ASSEMBLY

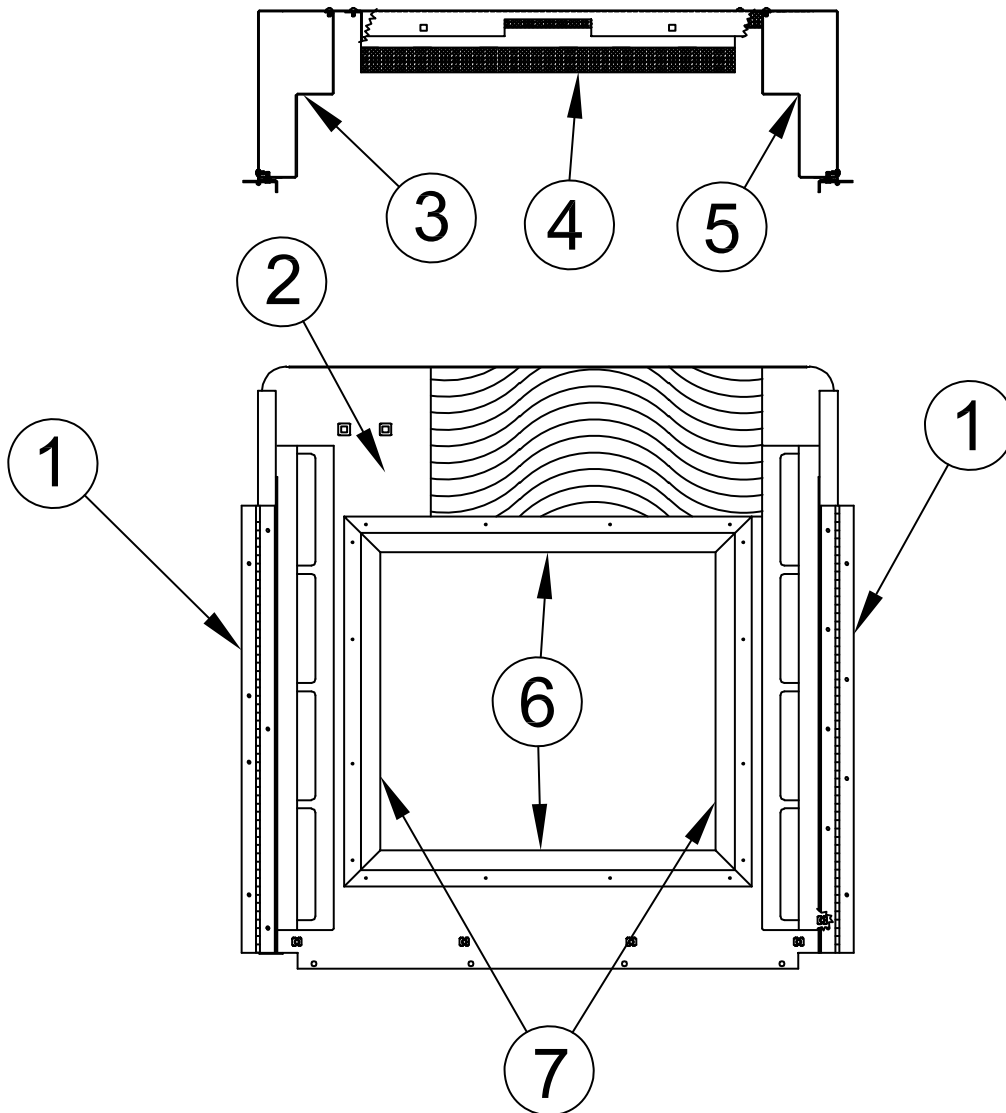

| REF # | PART NUMBER | QTY | DESCRIPTION |
|-------|-------------|------|----------------------|
| 1 | 98375-016 | 2 | Hinge |
| 2 | 99071-012 | 1 | Housing Front |
| 3 | 99378-026 | 1 | Left Baffle |
| 4 | 92421-000 | 7 FT | 1 1/2" Adhesive Foam |
| 5 | 99378-025 | 1 | Right Baffle |
| 6 | 99708-003 | 2 | Radiator Flange |
| 7 | 99708-002 | 2 | Radiator Flange |

CONTROL BOX ASSEMBLY

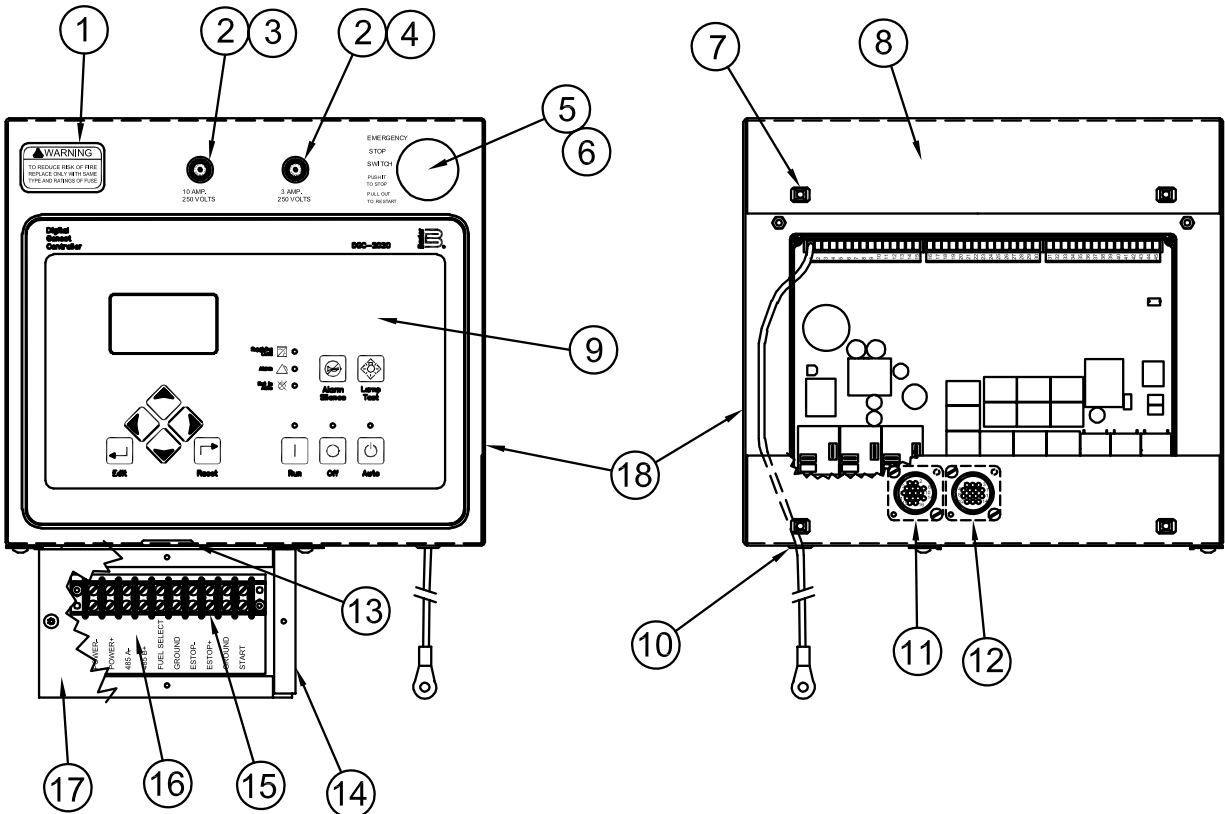

| REF # | PART NUMBER | QTY | DESCRIPTION |
|-------|-----------------|-----|----------------------------|
| 1 | 63941-004 | 1 | Fuse Warning Decal |
| 2 | 2489-001 | 2 | Fuse Holder |
| 3 | 95064-006 | 1 | 10 Amp Fuse |
| 4 | 95064-000 | 1 | 3 Amp Fuse |
| 5 | 99783-001 | 1 | Emergency Stop Switch |
| 6 | 99783-002 | 1 | Emergency Stop Block |
| 7 | 92495-000 | 4 | 1/4"-20 Retained Nut |
| 8 | 99055-012 | 1 | Control Box Panel |
| 9 | 351855-1 | 1 | Basler DGC-2020 Panel |
| 10 | 45853-000 | 1 | Grommet |
| 11 | 96925-006 | 1 | 16 Pin Connector |
| 12 | 96925-002 | 1 | 14 Pin Connector |
| 13 | 23917-000 | 1 | Grommet |
| 14 | 99873-402 | 1 | Control Box |
| 15 | 80623-006 | 1 | 10 Point Terminal Block |
| 16 | 64576-016 | 1 | Terminal Block Decal |
| 17 | 99873-401 | 1 | Control Box Cover Plate |
| 18 | 99977-415 | 1 | Control Box Assembly |
| NI | 300542 | 1 | Lithium Coin Style Battery |
| NI | Not Illustrated | | |

DC WIRING SCHEMATIC

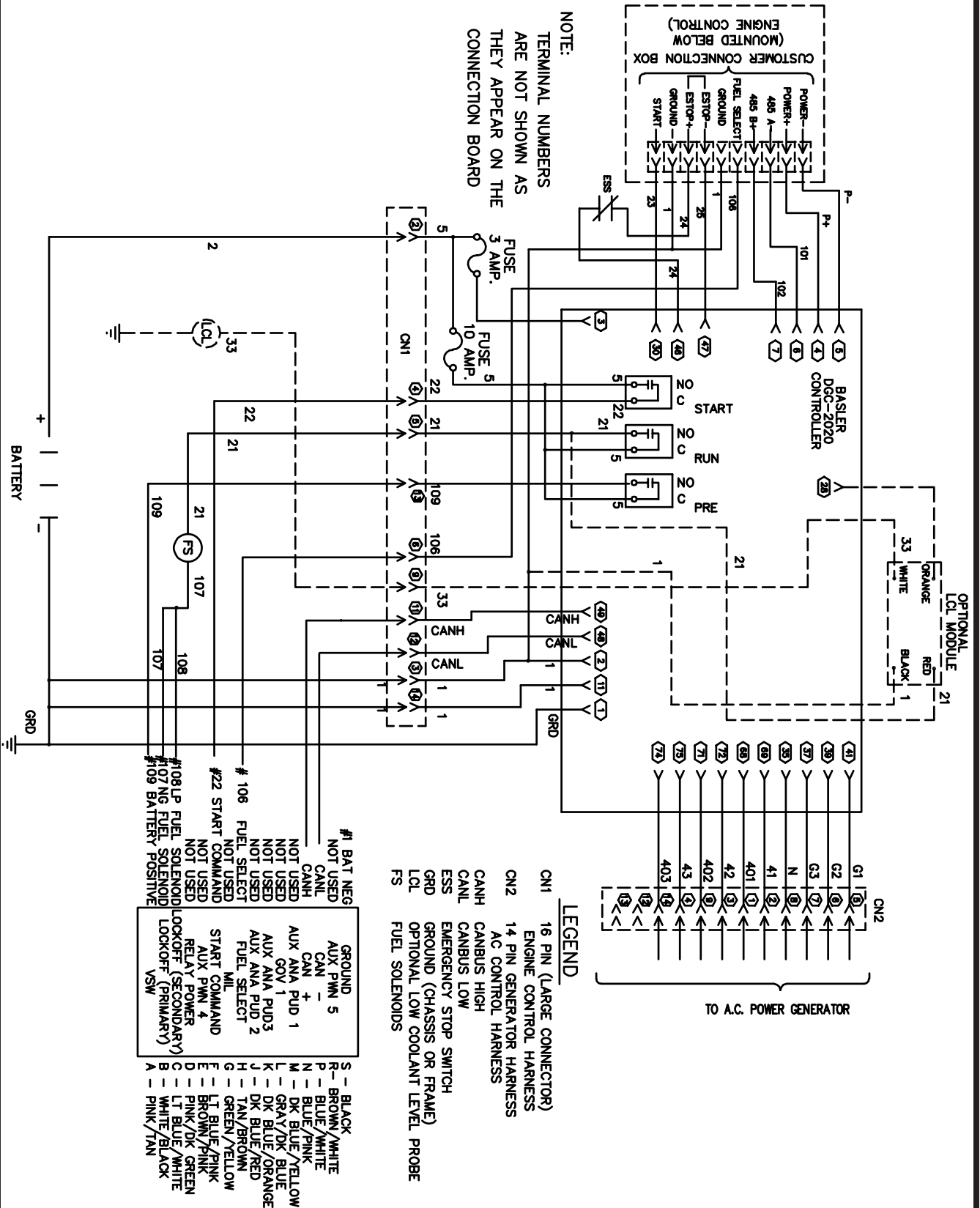

PSS30-3/A

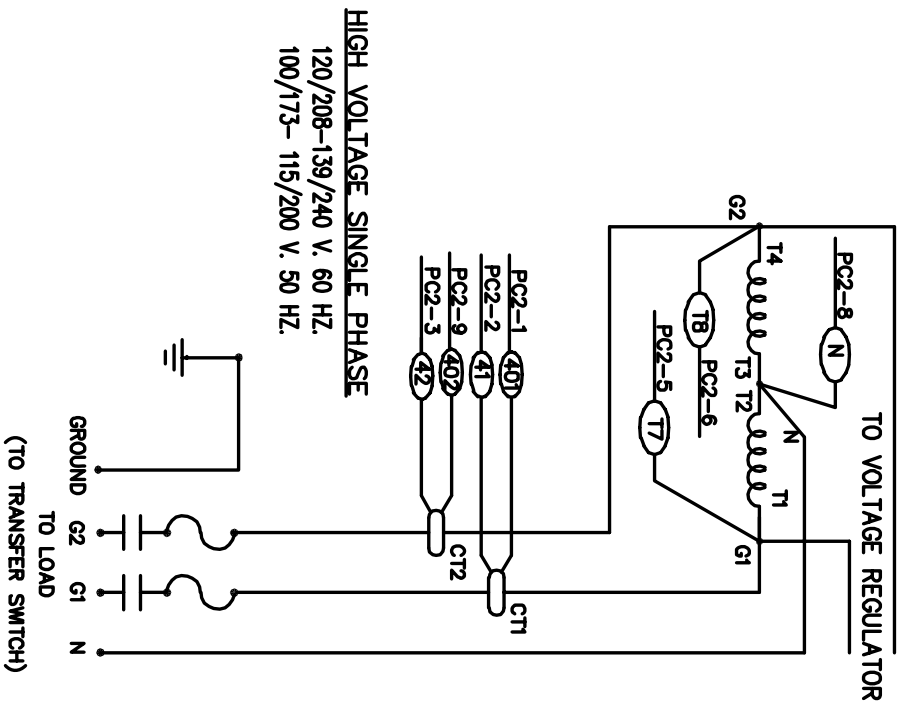

PSS30-18/A

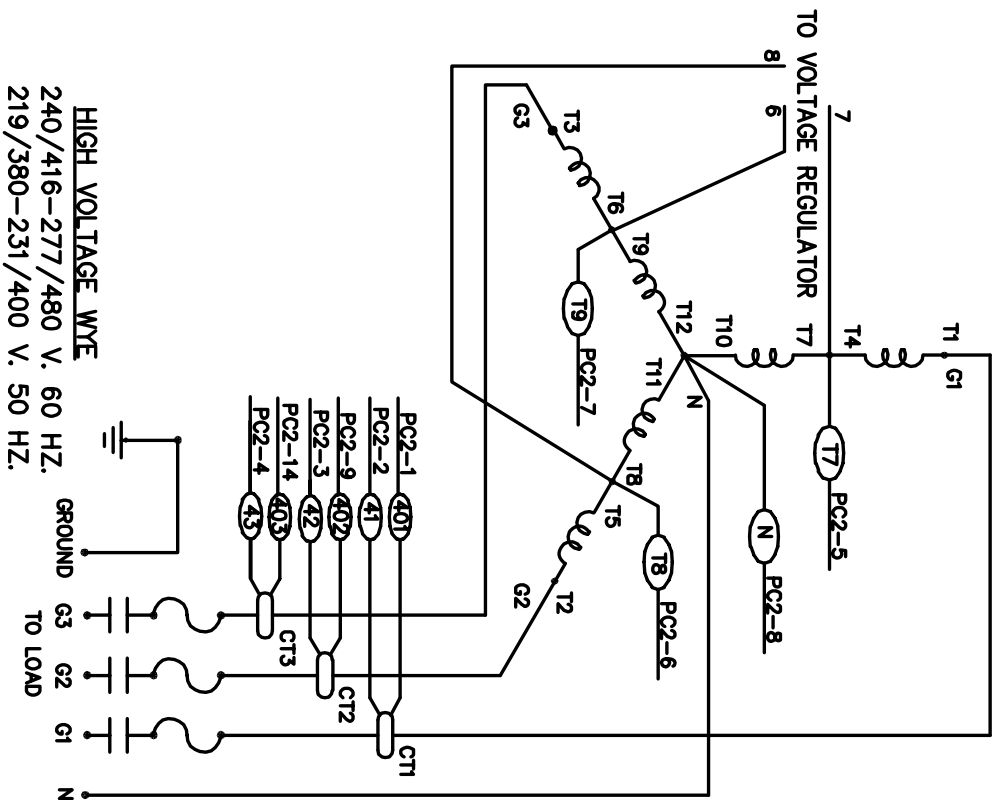

AC WIRING SCHEMATICS

PSS30-4/A

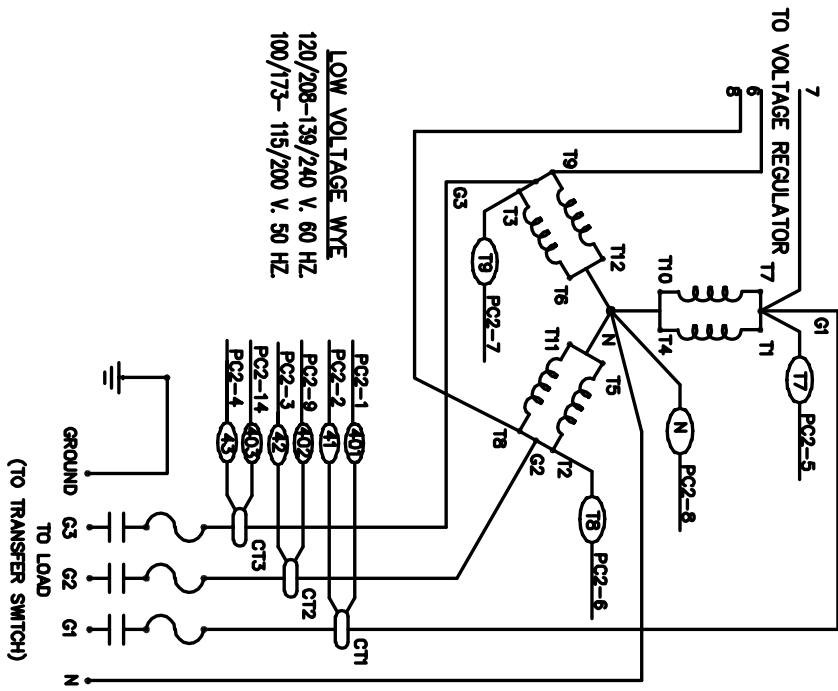

PSS30-17/A

