



## ILLUSTRATED PARTS LIST

**PSS35-3/F**

**PSS35-3/G**

**PSS35-4/F**

**PSS35-4/G**

**PSS35-17/F**

**PSS35-17/G**

**PSS35-18/F**

**PSS35-18/G**



225 S. CORDOVA AVE.  
LECENTER, MN 56057  
507-357-6821  
SERVICE DEPT.  
507-357-6831

# GENERATOR ASSEMBLY

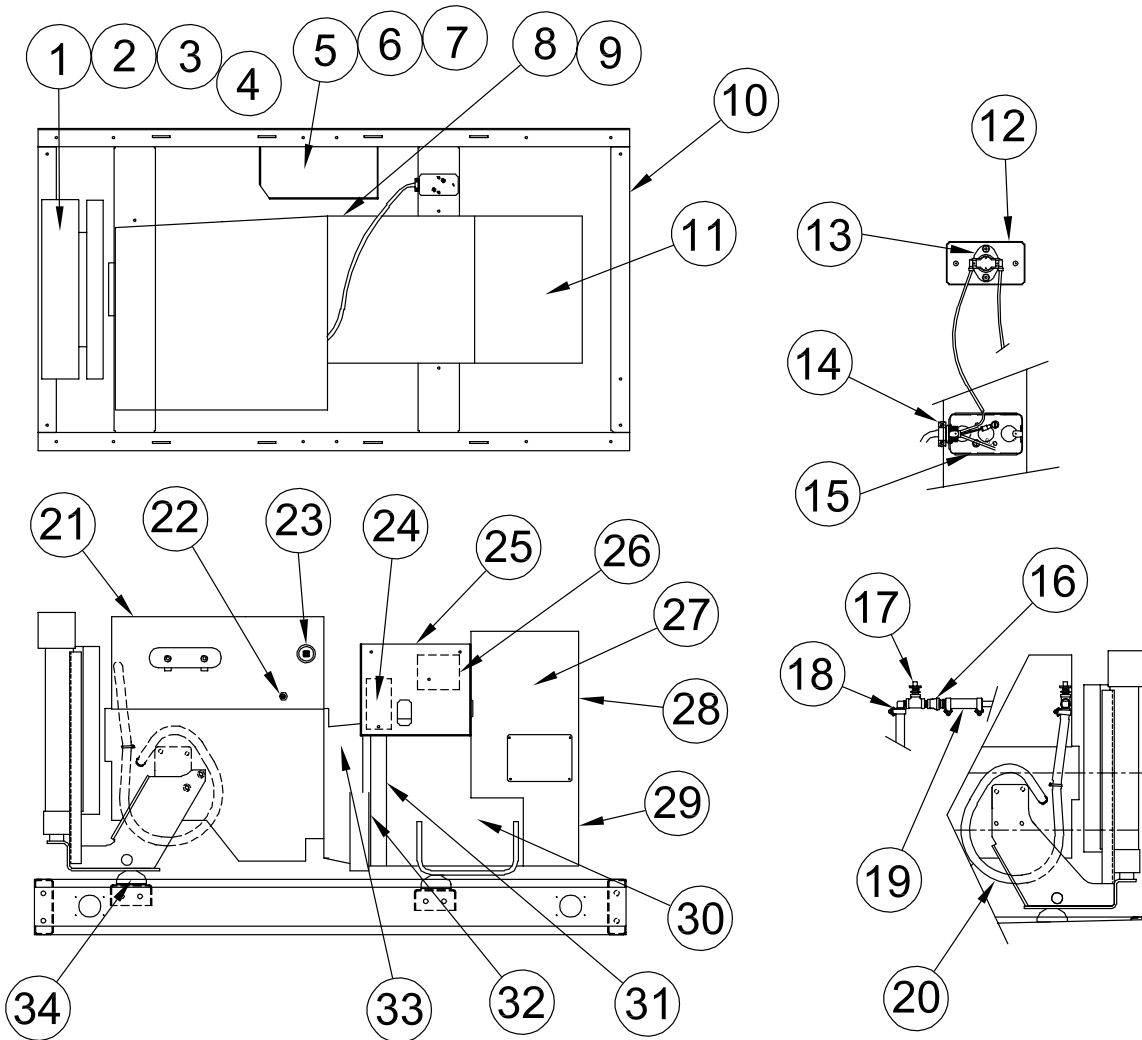

REF #	PART NUMBER	QTY	DESCRIPTION
1	Ford Part	1	Radiator
2	99375-000	1	Blower Fan
3	99395-000	1	Right Side Fan Guard
4	99396-000	1	Left Side Fan Guard
5	93569-001	1	Battery Rack
6	53220-057	1	Negative (-) Battery Cable
7	53220-056	1	Positive (+) Battery Cable
8	99473-000	1	Solenoid Mounting Bracket
9	80980-000	1	Start Solenoid
10	99059-001	1	Base Assembly

REF #	PART NUMBER	QTY	DESCRIPTION
11	92469-001	1	Top Cover
12	15812-000	1	Conduit Box Cover
13	15816-000	1	Temperature Sensor
14	93073-000	2	Conduit Connector
15	92789-000	2	Conduit Box
16	95954-000	1	Bell Reducer
17	93824-001	1	Petcock
18	92382-000	1	90° Elbow
19	93689-000	.34 FT	3/4" Hose
20	93689-001	3.41 FT	5/8" Hose
21	99657-000	1	Engine 2.5L Ford LRG425I-6005-F
22	99265-000	1	Water Temperature Sender
23	99267-001	1	Oil Pressure Sender
24	Reference	1	Ford Ignition Module
25	99057-000	1	Engine Control Support
26	99525-002	1	Governor Control
27	91642-001	1	Welded Box Assembly
28	92470-000	1	Upper Front Cover
29	91640-001	1	Lower Front Panel
30	92241-014	1	Generator Assembly
31	91337-000	1	Formed Cover
32	96000-004	12	3/8"-16 X 1.5" Bolt
33	350101-1	1	Magnetic Pick-up
34	98956-001	4	Shock Mounts
NI	D9AZ-6731-A	1*	FL-1-A Oil Filter
NI	AGSF-52C	4*	SP-442 Spark Plug
NI	AF1-8	1**	Air Cleaner
NI	98884-002	1	Voltage Regulator
NI	82505-003	1	Block Heater
NI	Not Illustrated		
*	Motorcraft part #		
**	IMPCO part #		

# FUEL SYSTEM ASSEMBLY NATURAL GAS & LP VAPOR

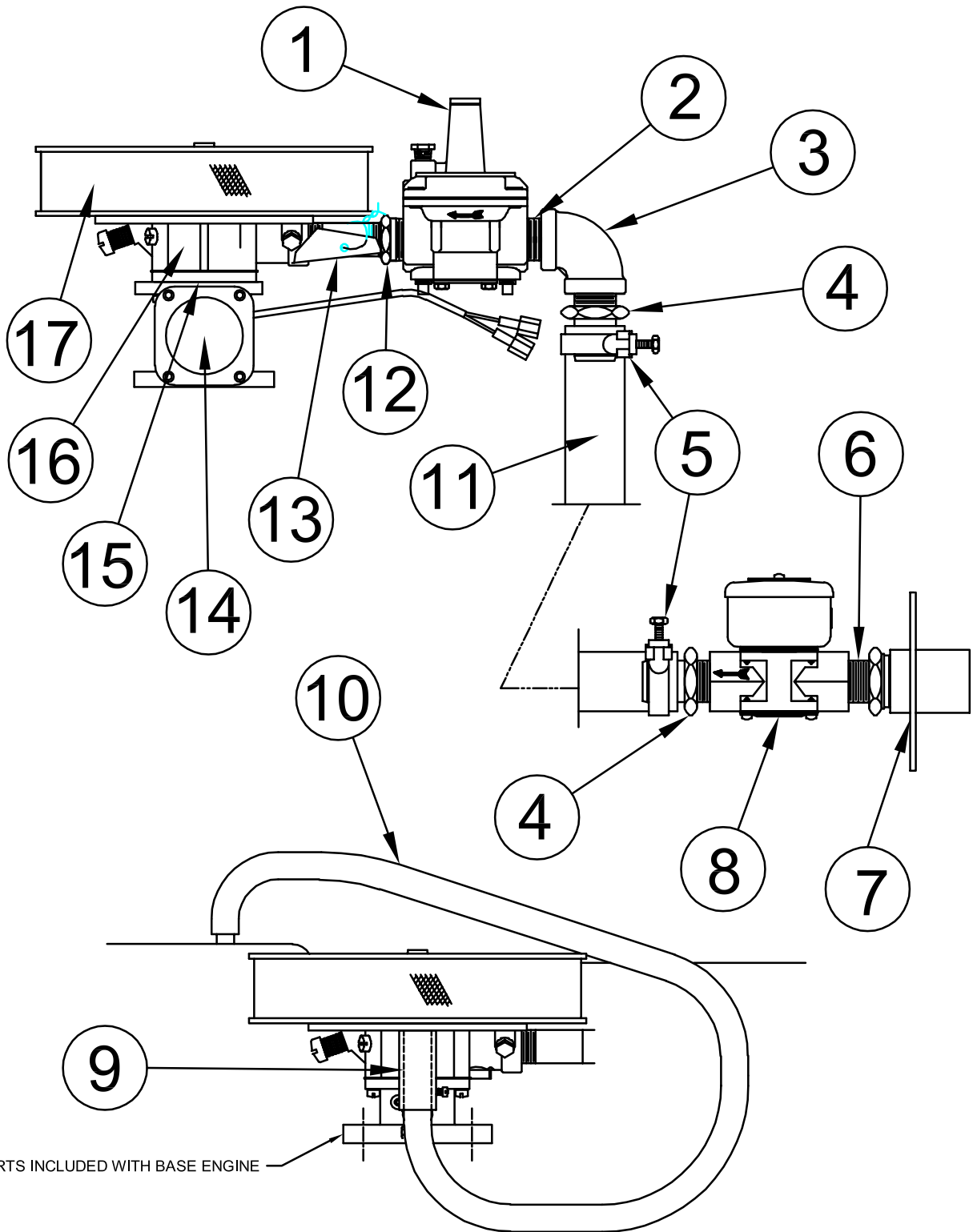

REF #	PART NUMBER	QTY	DESCRIPTION
1	50248-000	1	Regulator
2	22626-000	2	Pipe Nipple
3	50244-000	1	90° Elbow
4	92388-004	2	¾" to 1" Hose Fitting
5	50245-000	2	Clamp
6	81077-000	1	Bushing
7	99065-000	1	Fuel Cover Weldment
8	42942-000	1	Solenoid Valve
9	93689-001	.25 FT	Hose
10	94058-000	2.3 FT	Hose
11	49409-011	1	Hose 40" Long
12	81075-000	1	Pipe Bushing ½" M, ¾" F
13	24933-000	1	Pipe Nipple ½" X 4 ½"
14	350486	1	Governor Actuator
15	350136-000	1	Gasket
16	350495	1	Fuel Mixer
17	81073-000	1	Air Cleaner

## CONTROL CABINET ASSEMBLY

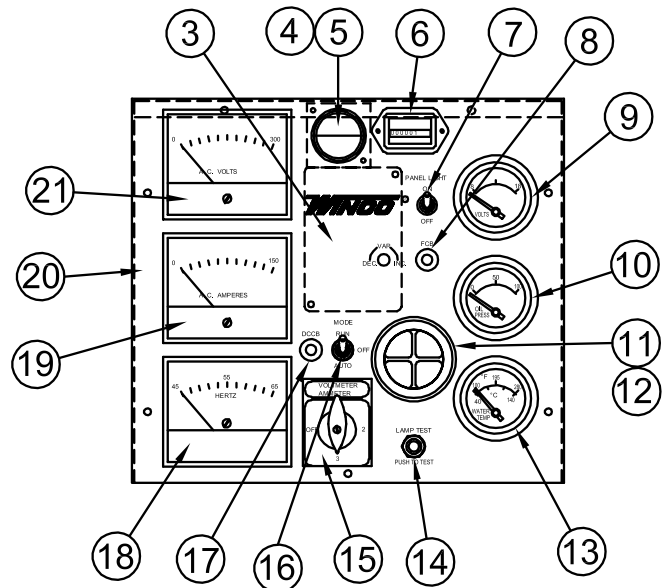
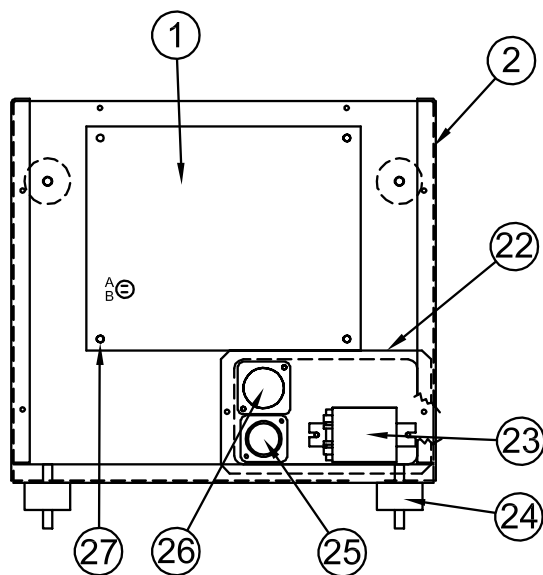

REF #	PART NUMBER	QTY	DESCRIPTION
1	72190-416	1	Engine Control Module
2	99056-000	1	Control Cabinet Back
3	98884-000	1	Voltage Regulator
4	99297-000	1	Light Backing Plate
5	95807-000	1	Panel Light
6	58166-006	1	Running Time Meter
7	71215-001	1	Toggle Switch
8	91286-007	1	5 Amp Circuit Breaker
9	99268-000	1	DC Voltage Gauge
10	99266-000	1	Oil Pressure Gauge
11	98946-001	1	Light Cluster
12	98947-000	1	Light Cluster Harness
13	99264-000	1	Water Temperature Gauge
14	71444-001	1	Push Button Switch
15	99003-001	1	Selector Switch -3 models
15	99003-000	1	Selector Switch -4, -17, -18
16	71216-001	1	Toggle Switch
17	91286-000	1	15 Amp Circuit Breaker
18	99272-002	1	Frequency Meter
19	99271-003	1	Ammeter -3 model
19	99271-002	1	Ammeter -4, -17 models
19	99271-006	1	Ammeter -18 model
20	99055-000	1	Control Cabinet Front
21	99270-003	1	Voltmeter -3, -4, -17 models
21	99270-002	1	Voltmeter -18 model
22	99343-000	1	Connector Mounting Plate
23	59944-006	1	Relay
24	71605-003	4	Shock Mount
25	96925-005	1	9 Pin Connector
26	96925-002	1	14 Pin Connector
27	91454-003	1	Spacer
NI	71234-005	2	Current Transformer -3 model
NI	71234-004	3	Current Transformer -4, -17
NI	71234-002	3	Current Transformer -18 model
NI	Not Illustrated		

# LP LIQUID WITHDRAWAL ASSEMBLY

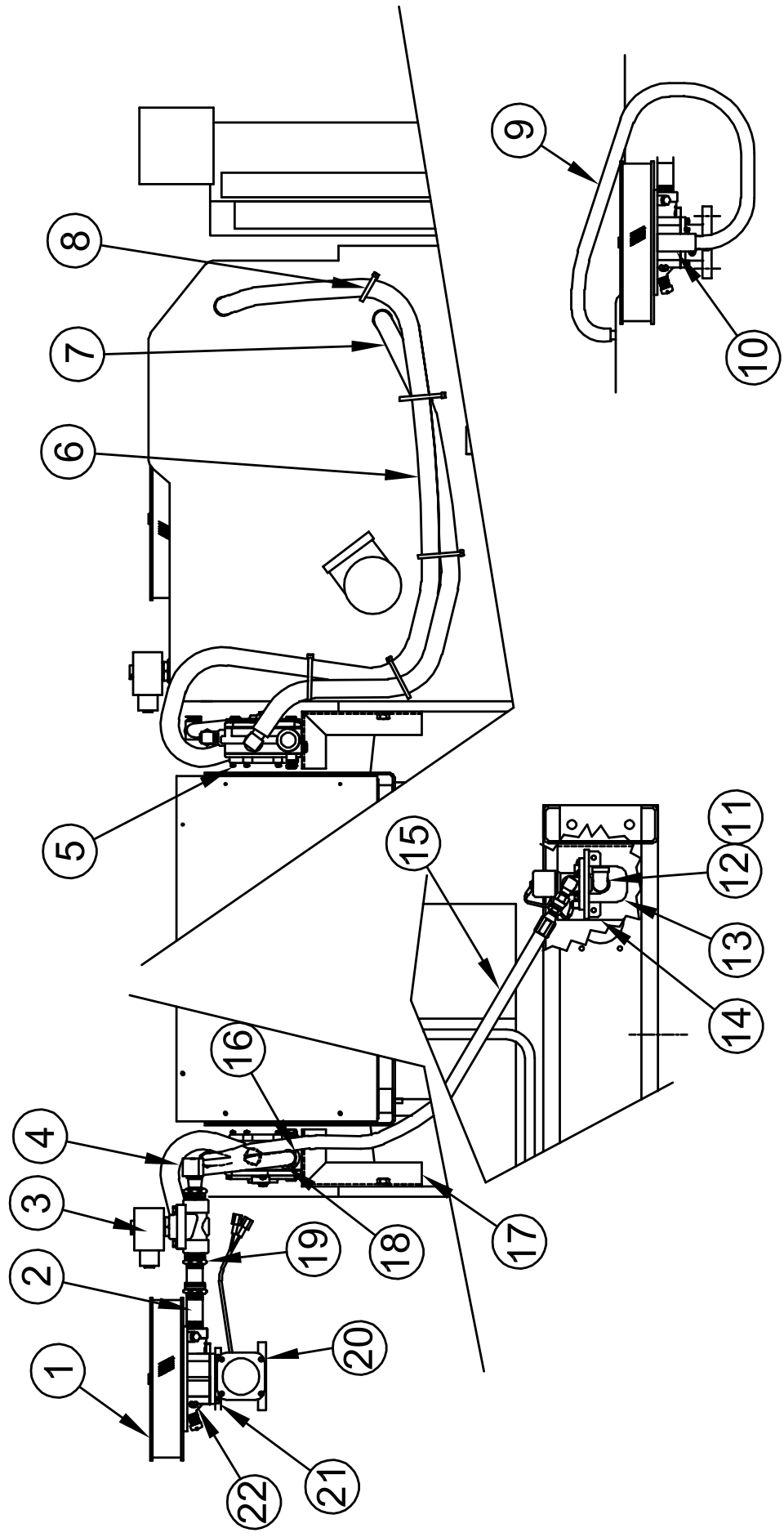

REF #	PART NUMBER	QTY	DESCRIPTION
1	81073-000	1	Air Cleaner
2	22399-000	1	Pipe Nipple
3	42942-000	1	Solenoid
4	92382-001	1	90° Reducer Elbow
5	81636-000	1	Converter - Regulator
6	93689-001	5' 8"	Hose
7	93689-001	3'	Hose
8	49975-011	6	Tie Wrap
9	94058-000	28"	Hose
10	93689-001	3"	Hose
11	81375-003	1	1/4" X 1 1/2" Nipple
12	92533-000	1	1/4" 90° Elbow
13	99475-000	1	Solenoid Valve
14	99085-001	1	Fuel Cover Plate
15	92940-006	1	Hose Assembly
16	92388-001	2	Brass Hose Fitting
17	99364-000	1	Mounting Bracket
18	56107-000	6.75"	Hose
19	81075-000	2	Pipe Busing 1/2" F 3/4" M
20	350486	1	Governor Actuator
21	350136	1	Gasket 1 1/2" Flange
22	350495	1	Carburetor

## BATTERY TENDER ASSEMBLY

**USED ON MODEL  
PSS35000/G ONLY**

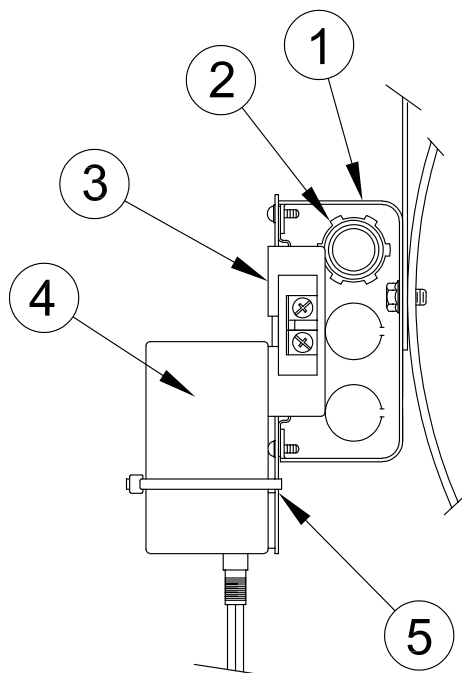

REF #	PART #	QTY	DESCRIPTION
1	92789-000	1	Conduit Box
2	93073-000	1	Conduit Connector
3	24749-000	1	Duplex Receptacle
4	16287-000	1	Battery Tender
5	59026-001	1	Rcpt. Cover Plate



# EXHAUST ASSEMBLY

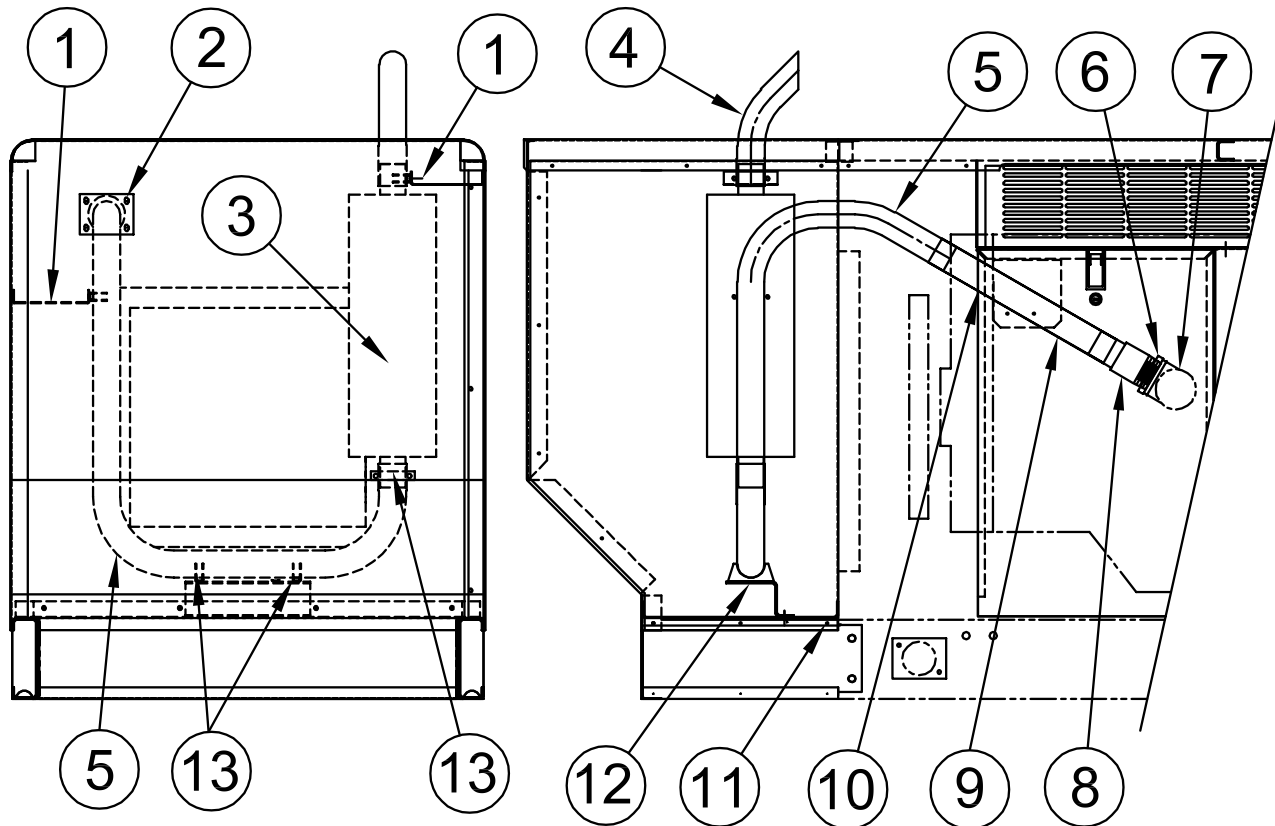

REF #	PART NUMBER	QTY	DESCRIPTION
1	99291-000	2	Exhaust Support
2	99060-001	1	Cover Plate
3	80519-001	1	Muffler
4	99299-000	1	Tail Pipe
5	99298-000	1	Exhaust Pipe
6	63274-000	1	Flange Adapter
7	92042-002	1	90° Elbow
8	99294-000	1	Exhaust Adapter
9	98412-002	1	Flex Exhaust Pipe
10	97274-000	40 FT	High Temperature Tape
11	99223-000	1	Air Chamber Floor
12	99234-000	1	Exhaust Support
13	93489-003	7	Muffler Clamp

# GENERATOR ADAPTER ASSEMBLY

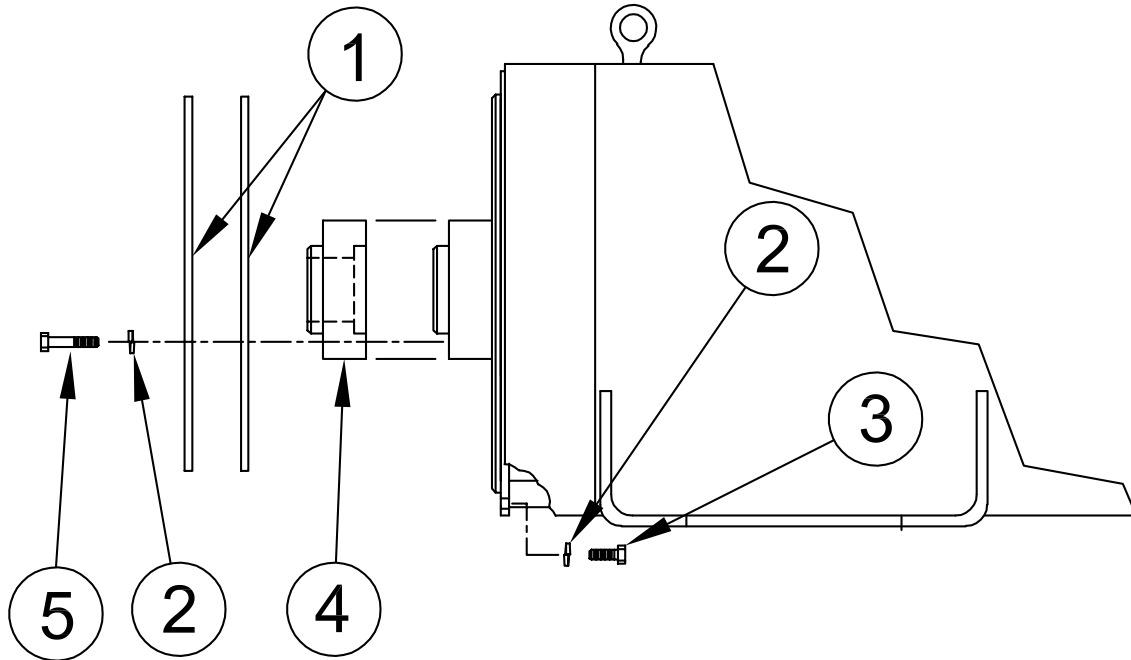

REF #	PART NUMBER	QTY	DESCRIPTION
1	91564-000	2	Drive Disk
2	481-001	18	Split Lock Washer
3	96000-004	12	3/8"-16 X 1.5" Bolt
4	91524-000	1	Drive Disk Spacer
5	96000-007	6	3/8"-16 X 2.25" Bolt

# GENERATOR ASSEMBLY

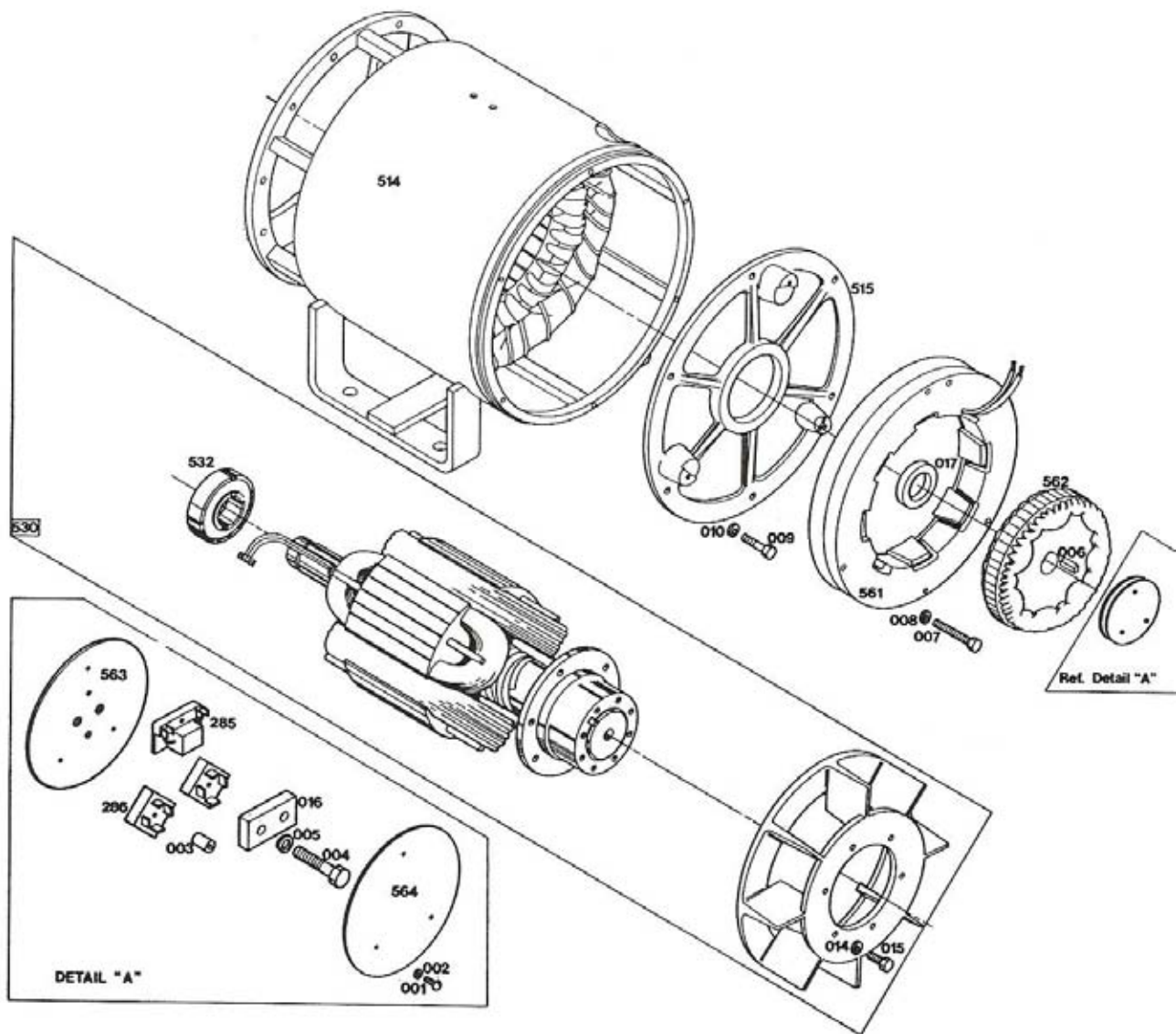

REF #	PART NUMBER	QTY	DESCRIPTION
001	91410-000	3	10-32 X 7/8" Threaded Stud
003	91454-001	3	10-32 X 3/4" Spacer
004	93617-005	2	7/16-14 X 1.5" Bolt
005	90570-001	2	Lock Washer
006	93622-000	1	Key
007	91431-000	3	1/4-28 X 2.75" Bolt
008	479-000	3	Split Lock Washer
009	91256-000	6	7/16-14 X 1.75" Bolt
010	90570-000	6	Split Lock Washer
016	93616-000	1	Exciter Retainer Bar

REF #	PART NUMBER	QTY	DESCRIPTION
017	93615-000	1	Exciter Support Collar
285	91455-000	1	Surge Suppressor
286	91452-000	2	Bridge Rectifier
514	92239-014	1	Stator Assembly
515	91620-000	1	End Bracket
530	92244-005	1	Rotor Assembly
532	91627-000	1*	Bearing
561	91665-000	1	Exciter Stator
562	91442-000	1	Exciter Rotor
563	91411-000	1	Retainer
564	91491-000	1	Insulator
*			Comes with rotor assy.
Detail			
A	91413-000	1	Complete Retainer Assembly

## DECALS

REF #	PART NUMBER	QTY	DESCRIPTION
NI	15750-001	1	Ground Decal
NI	97813-000	3	Auto Start Warning
NI	15209-000	1	Warning Decal
NI	56596-000	1	Fuel Decal
NI	56597-000	1	Fuel Decal
NI	63941-001	1	Hot Surface Decal
NI	64891-001	1	Electrical Code Decal
NI	63941-003	1	Battery Warning Decal
NI	Not Illustrated		

# HOUSING ASSEMBLY

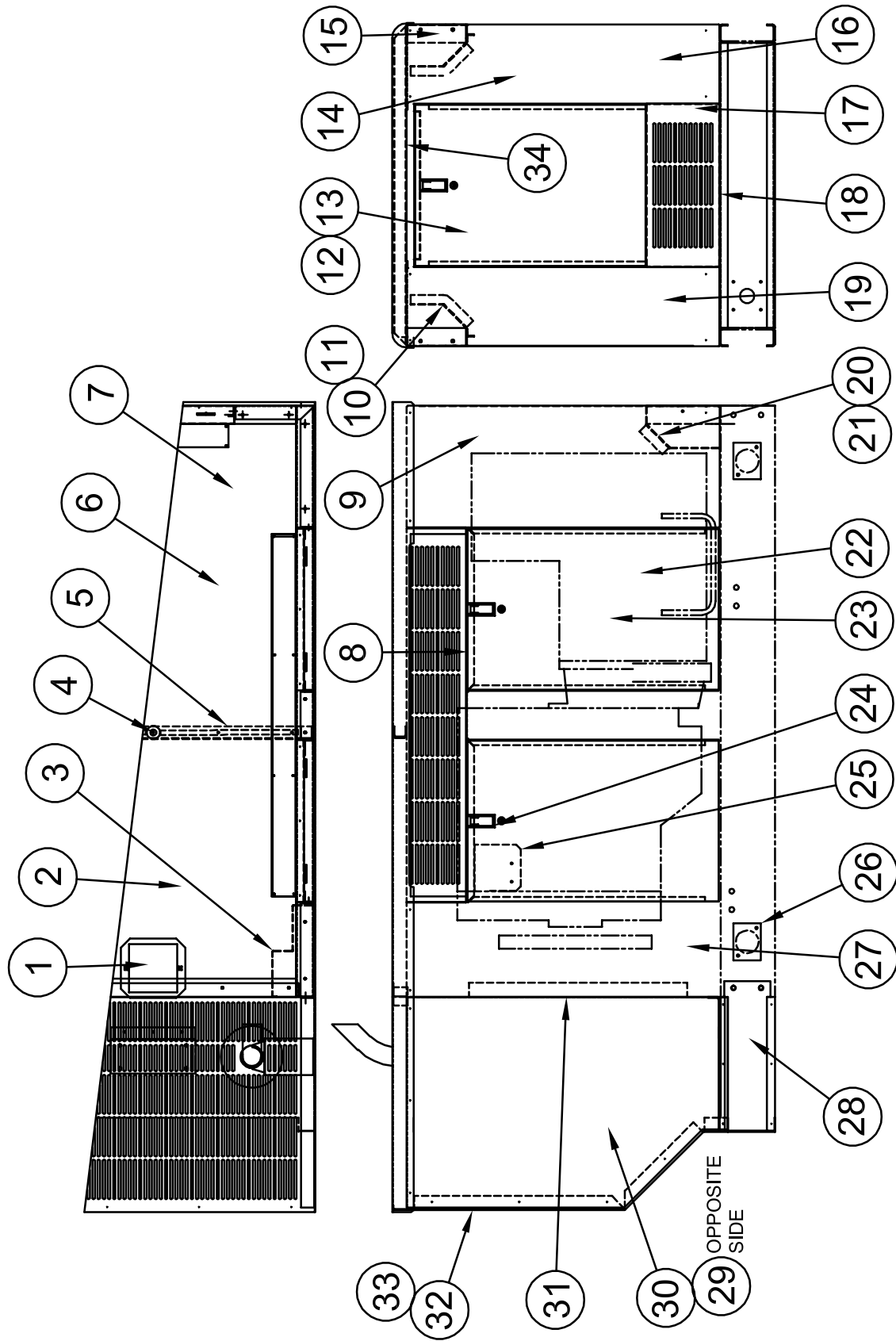

REF #	PART NUMBER	QTY	DESCRIPTION
1	62026-003	1	Cover Plate
2	99393-402	1	Foam Piece
3	99378-001	2	Front Housing Baffle
4	62825-011	1	Spacer
5	99225-000	1	Roof Support
6	99393-405	1	Foam Piece
7	99086-002	1	Roof
8	99224-000	4	Door Jam
9	99393-411	2	Foam Piece
10	99103-001	2	Backing Plate
11	99393-408	4	Foam Piece
12	99393-413	1	Door Foam
13	15680-006	1	Rear Door
14	99393-410	2	Foam Piece
15	99098-000	2	Sill
16	99067-001	1	Right Rear Corner Post
17	99100-000	1	Rear Sill
18	466-000	4	1/4"-20 X 3/4" Bolt
19	99067-000	1	Left Rear Corner Post
20	99393-404	1	Foam Piece
21	99103-000	1	Backing Plate
22	99393-412	4	Door Foam
23	15680-002	4	Side Door
24	95229-002	5	Door Latch
25	99500-000	1	Heat Shield
26	99060-000	4	Cover Plate
27	99071-001	1	Housing Front
28	99079-000	2	Base Extension
29	99392-001	1	Right Side Extension
30	99392-000	1	Left Side Extension
31	92421-000	8 FT	Foam
32	99083-001	1	Front Extension Panel
33	99393-406	1	Foam Piece
34	99391-000	1	Roof End
NI	62912-000	40 FT	Foam Strip
NI	Not Illustrated		

# DC WIRING SCHEMATIC

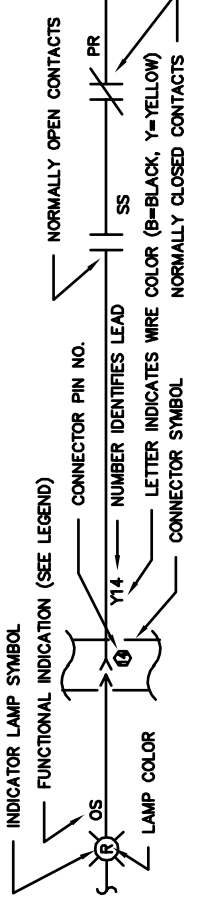
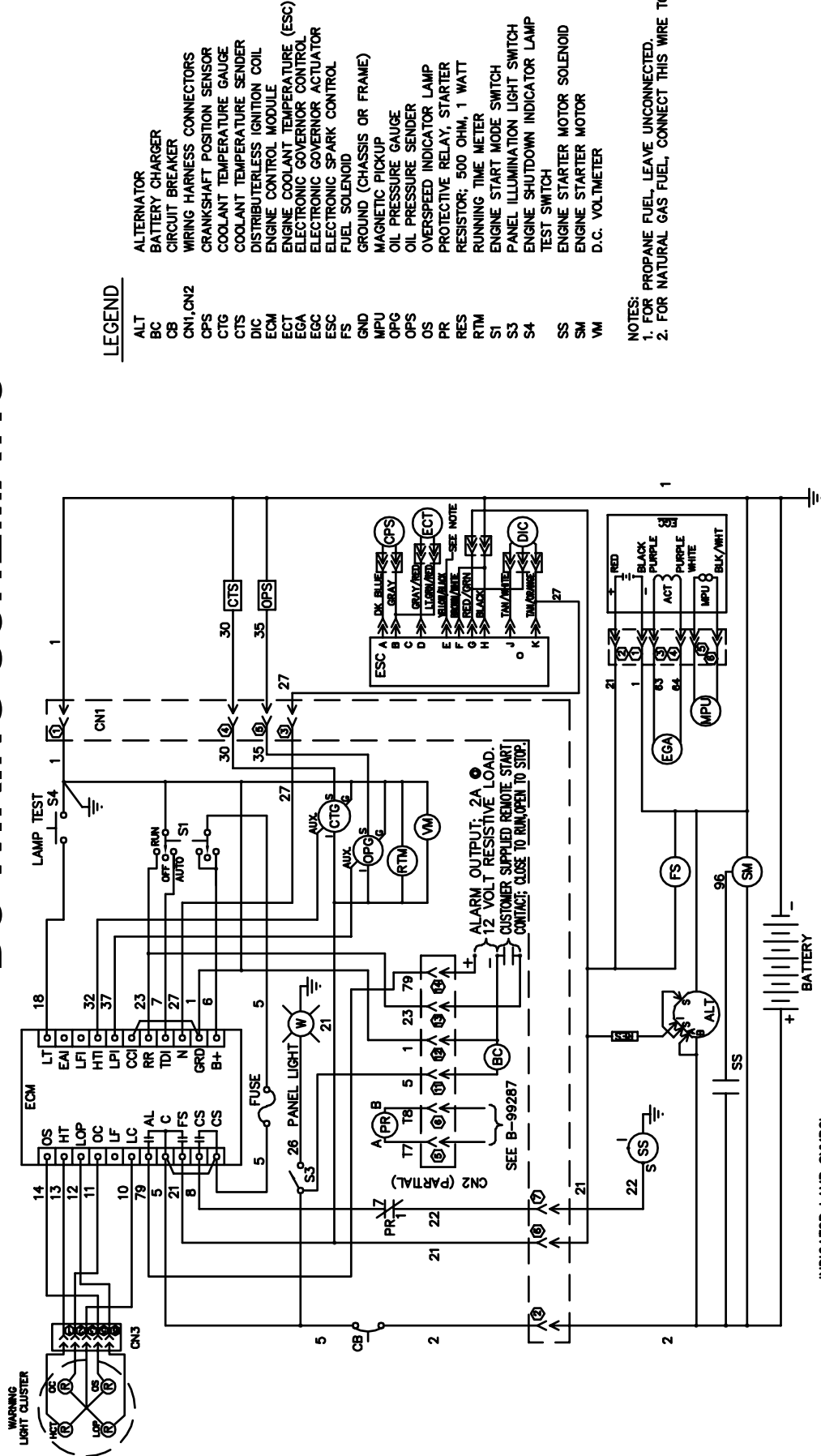

# VOLTAGE REGULATOR WIRING

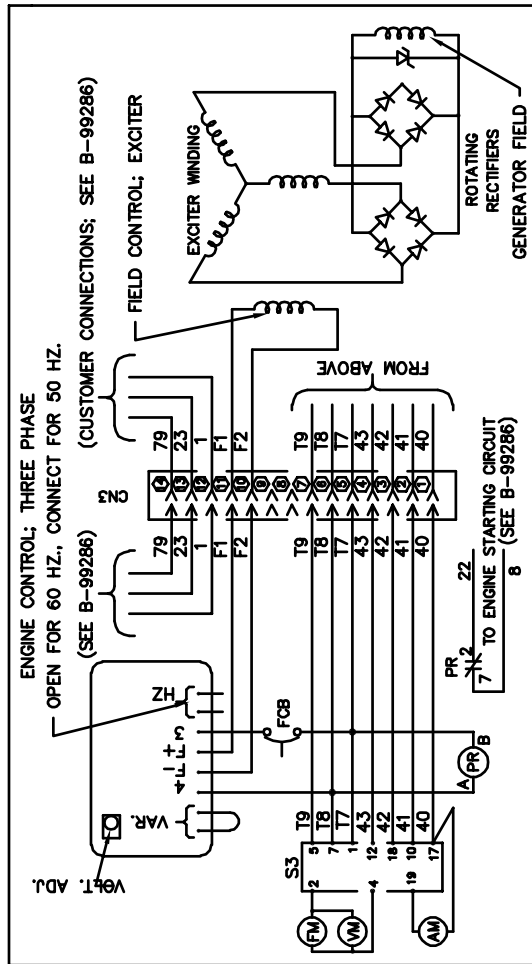
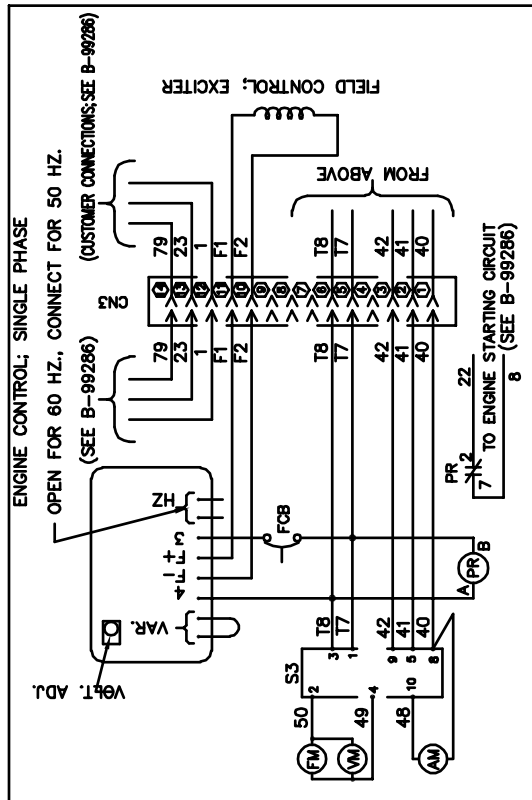



# AC WIRING SCHEMATIC

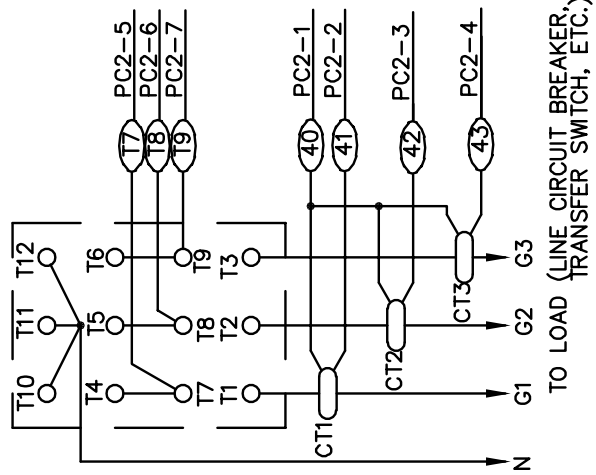
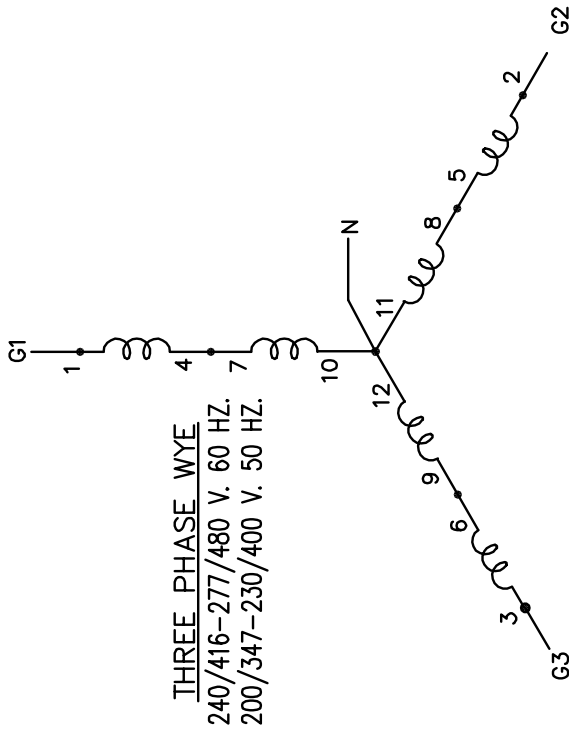

**PSS35000-17/F & /G**

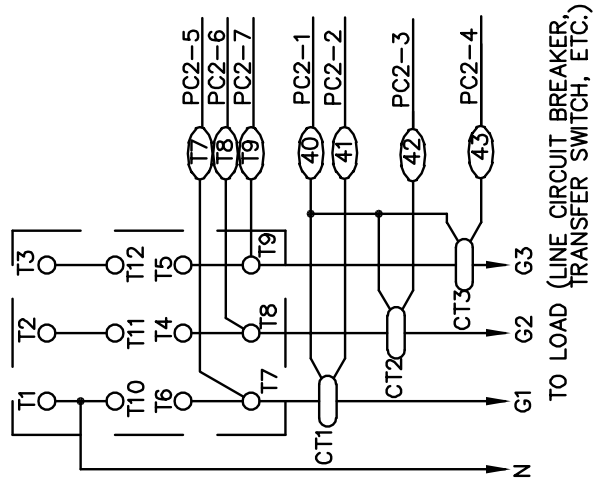
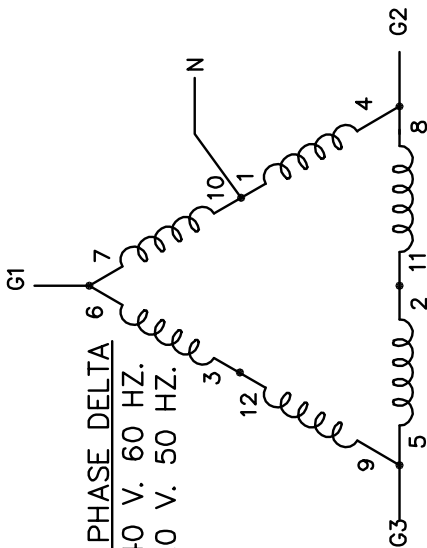

**PSS35000-18/F & /G**

# AC WIRING SCHEMATIC

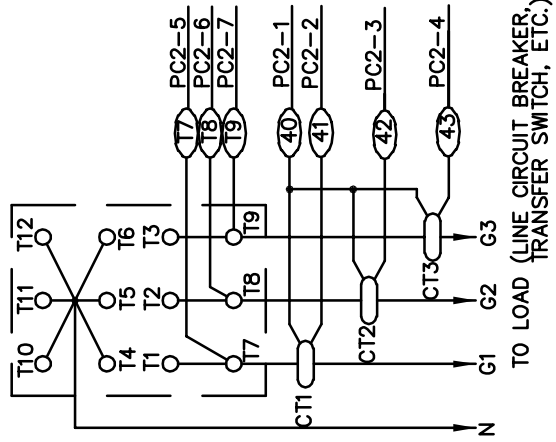
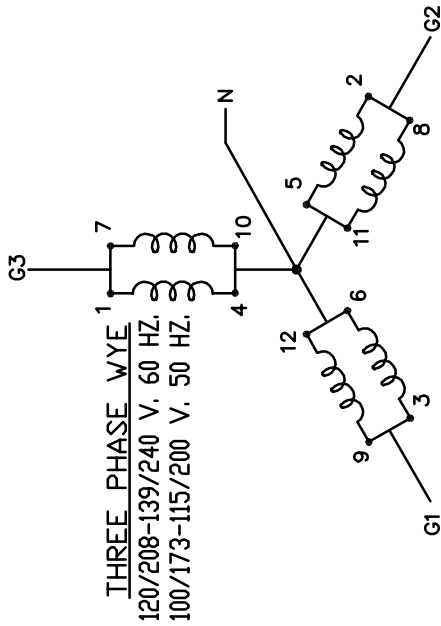

## PSS3500-4/F & /G

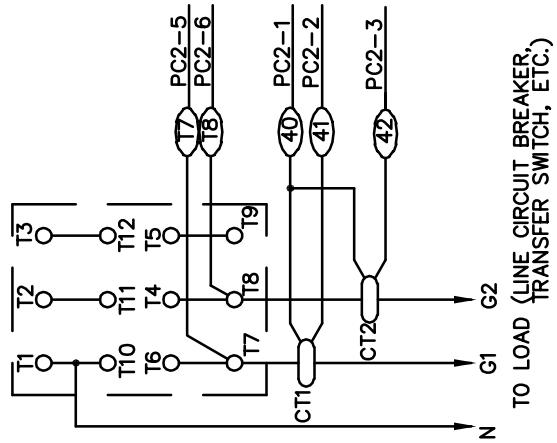
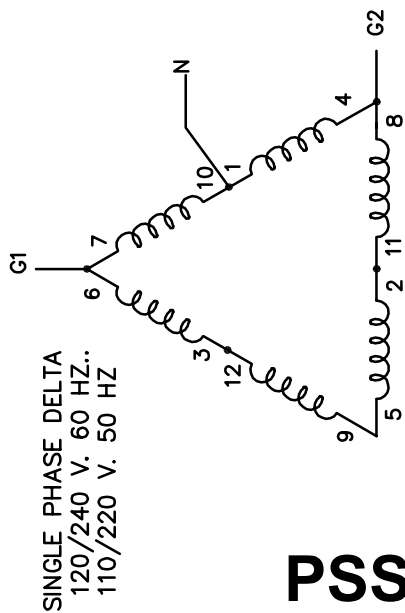

## PSS3500-3/F & /G