

24018-009

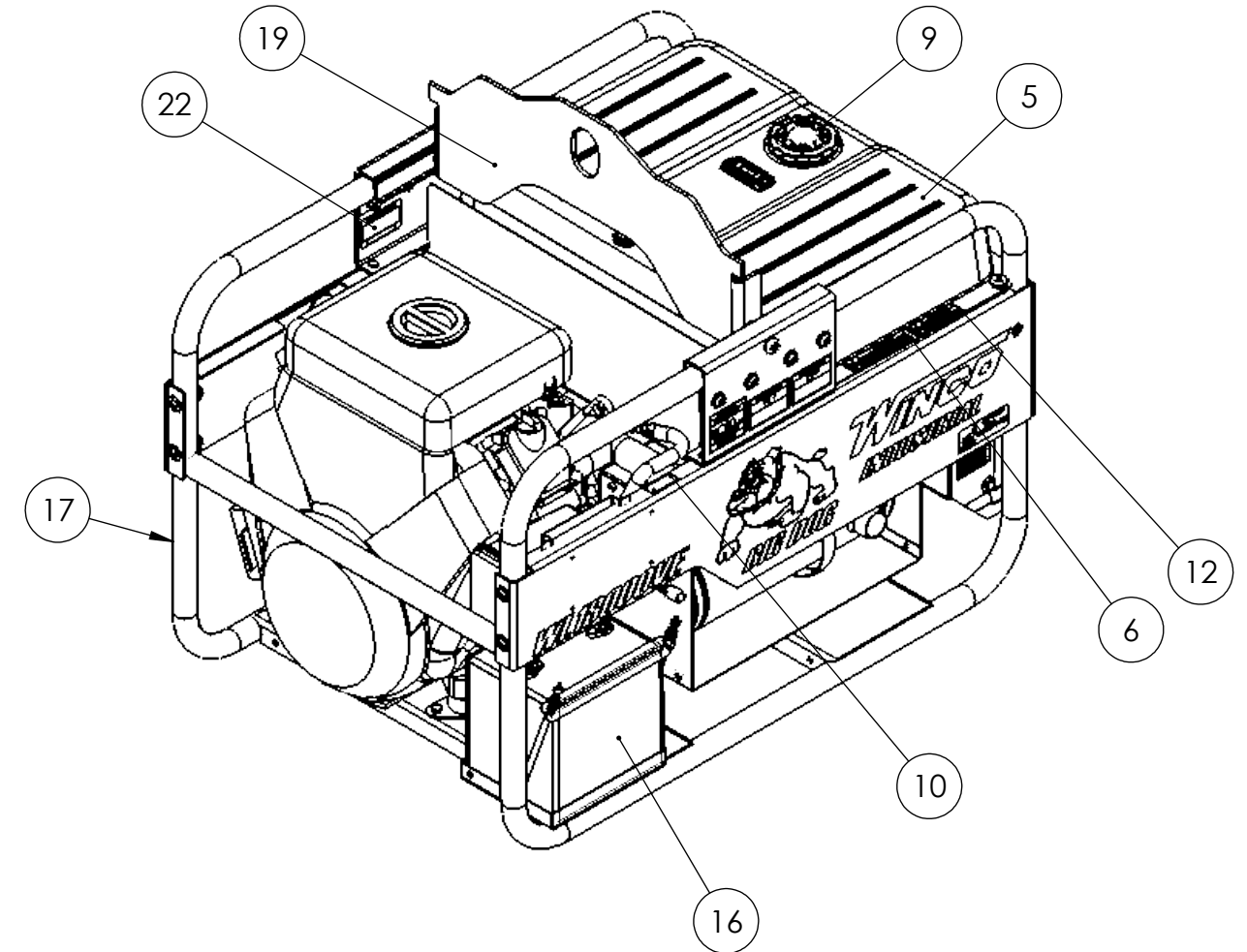
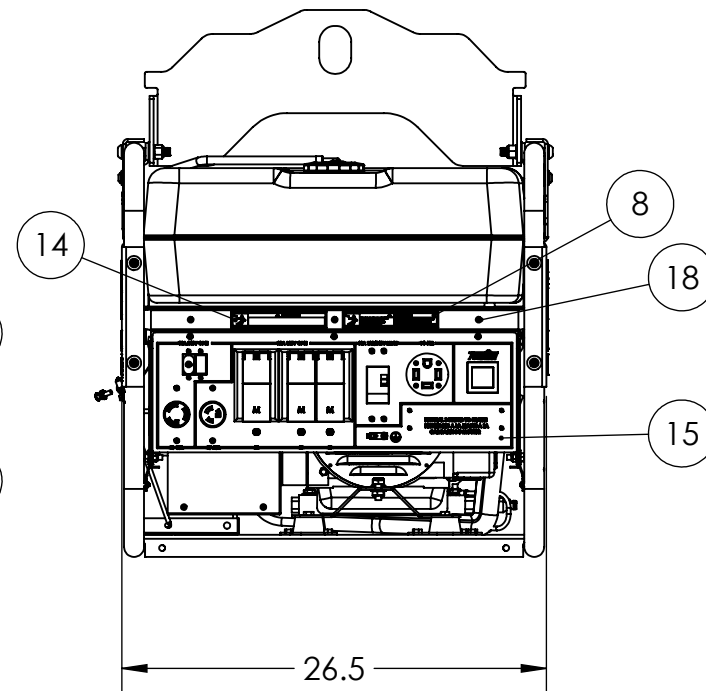
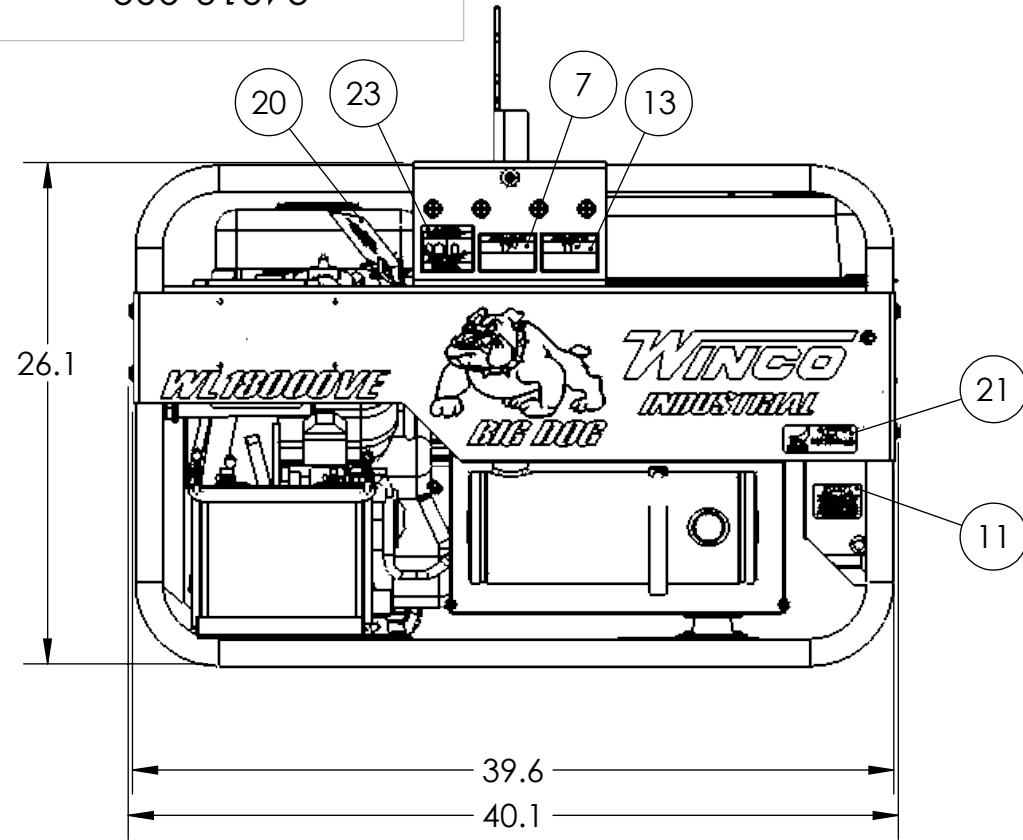

REVISIONS					
REV.	IRN	DESCRIPTION	DATE	BY	APP'D
A	P281	ORIGINAL	8/27/2018	SJM	DRD
B	10755	ADDED DECAL KIT	02/05/2020	SSB	DRC

ITEM NO.	PartNo	DESCRIPTION	QTY.
1	100047-742	CARTON	1
2	100054-514	BAG 54 X 52 X 60 1.0 MIL	1
3	OPM-138	OPR MANUAL WL18000	1
4	100114-705	PALLET	1
5	15163-072	FUEL TANK INSTALLATION	1
6	15209-001	GASOLINE DECAL	1
7	15209-002	DECAL-DANGER CARBON MONOXIDE	1
8	15209-003	UL-DECAL ELECTRICAL SHOCK CAN KILL	1
9	15209-013	DECAL - FUEL TYPE GASOLINE	1
10	15209-014	DECAL - CHECK OIL	1
11	15209-036	PROP 65 WARNING DECAL	1
12	15209-101	DECAL, GASOLINE DANGER, FRENCH	1
13	15209-102	DECAL-DANGER CARBON MONOXIDE	1
14	15209-103	UL-DECAL ELECTRICAL SHOCK CAN KILL	1
15	15457-084	RECEPTACLE ASSEMBLY	1
16	16175-029	BATTERY INSTALLATION	1
17	18000-002	ENGINE GENERATOR AND CRADLE	1
18	21698-001	TORX PAN HEAD SCREW #10	5
19	300144-14	LIFTING EYE ASSEMBLY	1
20	60710-018	OIL WARNING TAG	2
21	63941-001	DECAL -HOT SURFACES	1
22	63966-004	NAMEPLATE, WINCO PORTABLE	1
23	64918-000	DECAL-DANGER (CO) USE OUTSIDE	1
25	15715-095	DECAL KIT, PACKAGING, BIG DOG STYLE, STACK 2	1

<p>THIS DRAWING CONTAINS PROPRIETARY INFORMATION BELONGING TO WINCO. UNAUTHORIZED USE IS PROHIBITED.</p> <p>ALL DIMENSIONS INCH</p>	DRAWN BY	DATE	CHK'D BY	DATE	ENG APPR.	DATE
	SJM	8/27/2018			DRD	3/15/19
	TOLERANCE:	+/- 0.0625 DECIMAL		TITLE: WL18000VE-03/A		
	MODEL:	WL18000VE-03/A		PART: 24018-009		