

16400-055

AC PANEL OPEN DOOR

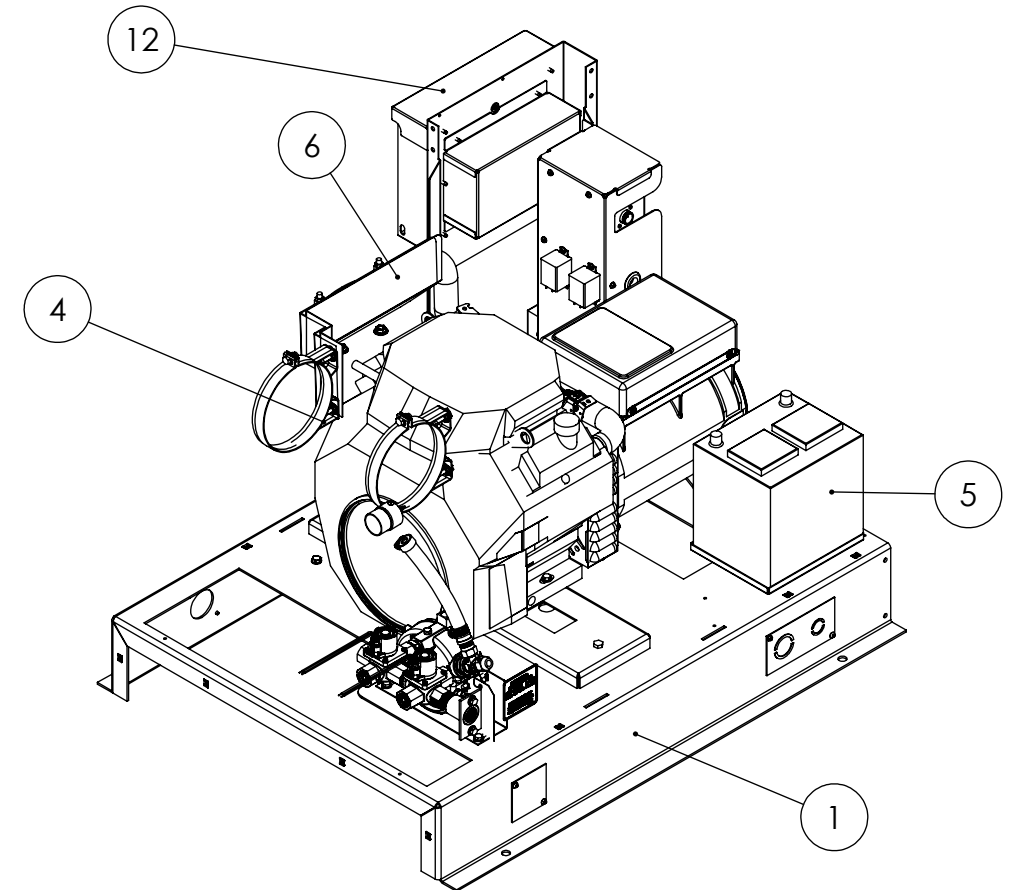
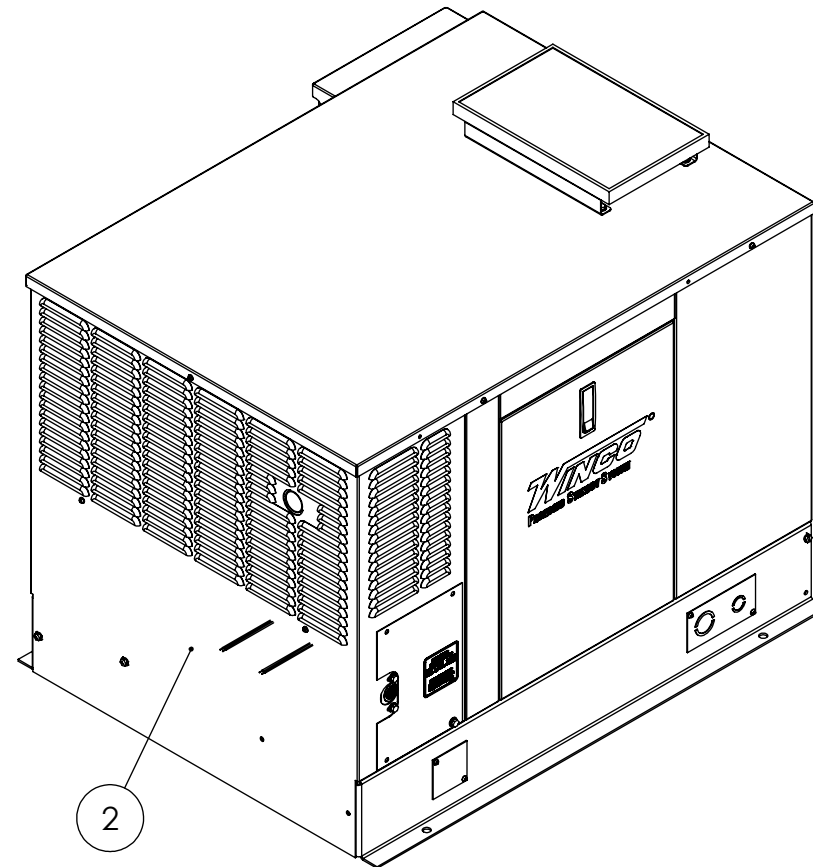
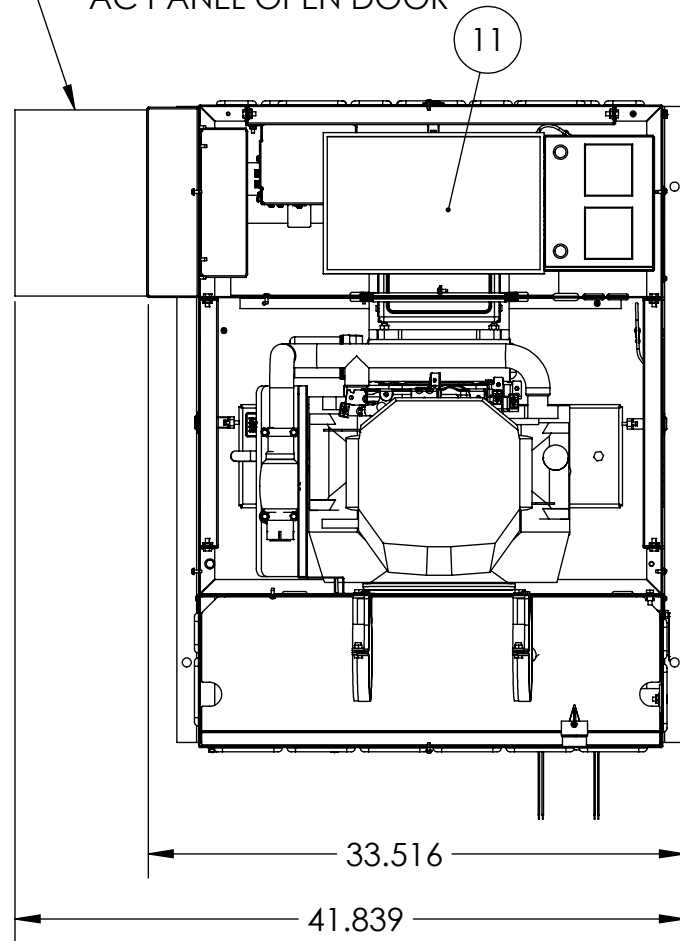

REVISIONS

REV.	IRN	DESCRIPTION	DATE	BY	APP'D
A	P294	ORIGINAL	10/18/2017	BWZ	DRD
B	8413	UPDATED AFTER PILOT	3/22/2018	BWZ	DRD
C	8182	APPLIED NEW FUEL SYSTEM	7/18/2018	BWZ	DRD

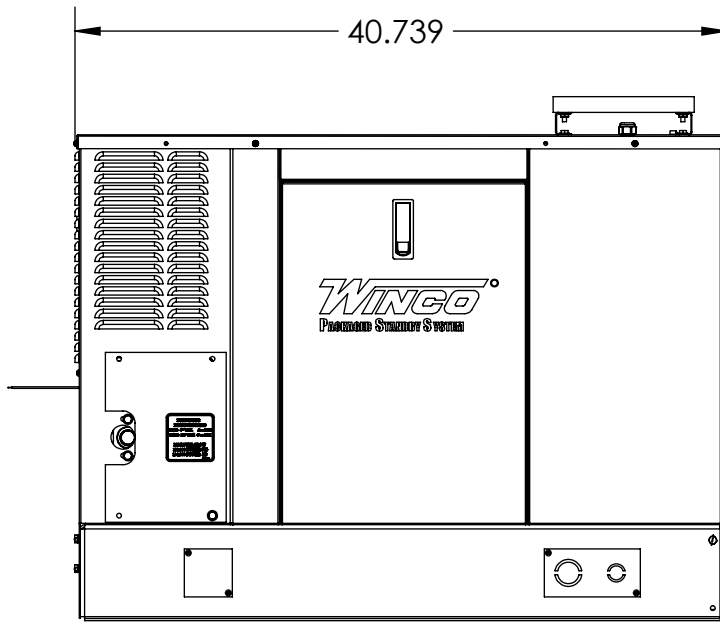
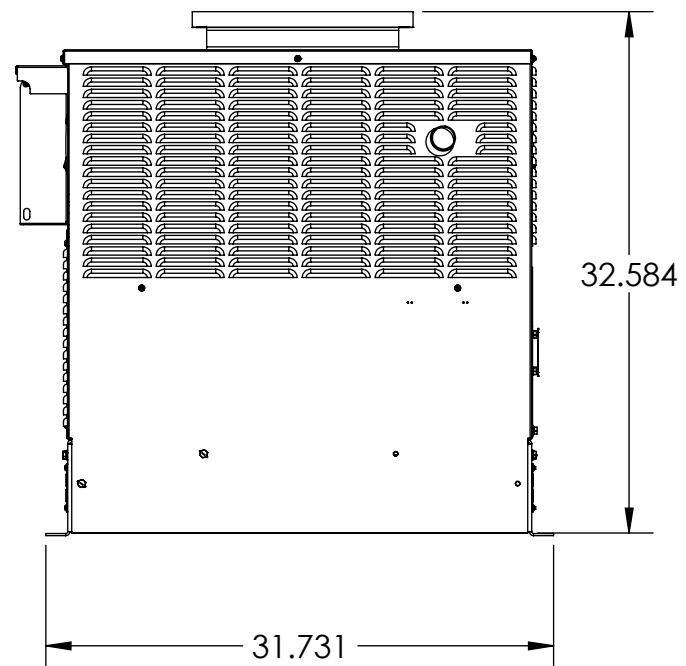

ITEM NO.	PartNo	DESCRIPTION	QTY.
1	16391-009	ENG/GEN/BASE ASSY	1
2	16393-015	HOUSING ASSY SOLAR	1
3	16397-010	FUEL SYSTEM INSTALL	1
4	16394-004	EXHAUST SYSTEM INSTALL	1
5	16328-005	BATTERY INSTALL	1
6	15687-009	HEAT SHIELD	1
7	15715-081	DECAL AND NAMEPLATE INSTALLATION PSS UNITS	1
8	15768-022	TWO WIRE CONTROL DECAL	1
9	60706-209	PSS12 2-WIRE START MANUAL	1
10	60710-018	TAG-OIL WARNING	1
11	405020-008	SOLAR BATTERY CHARGER KIT 12V 5W .3A	1
12	16477-010	CONTROL TOWER INSTALL	1
13	100114-729	SHIPPING PALLET	1

<p>THIS DRAWING CONTAINS PROPRIETARY INFORMATION BELONGING TO WINCO. UNAUTHORIZED USE IS PROHIBITED.</p> <p>ALL DIMESNIONS INCH</p>	DRAWN BY BWZ	DATE 10/18/2017	CHK'D BY	DATE	ENG APPR. DRD	DATE 11/14/17
	TOLERANCE:	+/- 0.0625 DECIMAL M/A DEG ANGULAR		TITLE: FINAL ASSEMBLY		
	MODEL:	ULPSS12H2W_F SOLAR		PART: 16400-055		

