

D

C

B

A

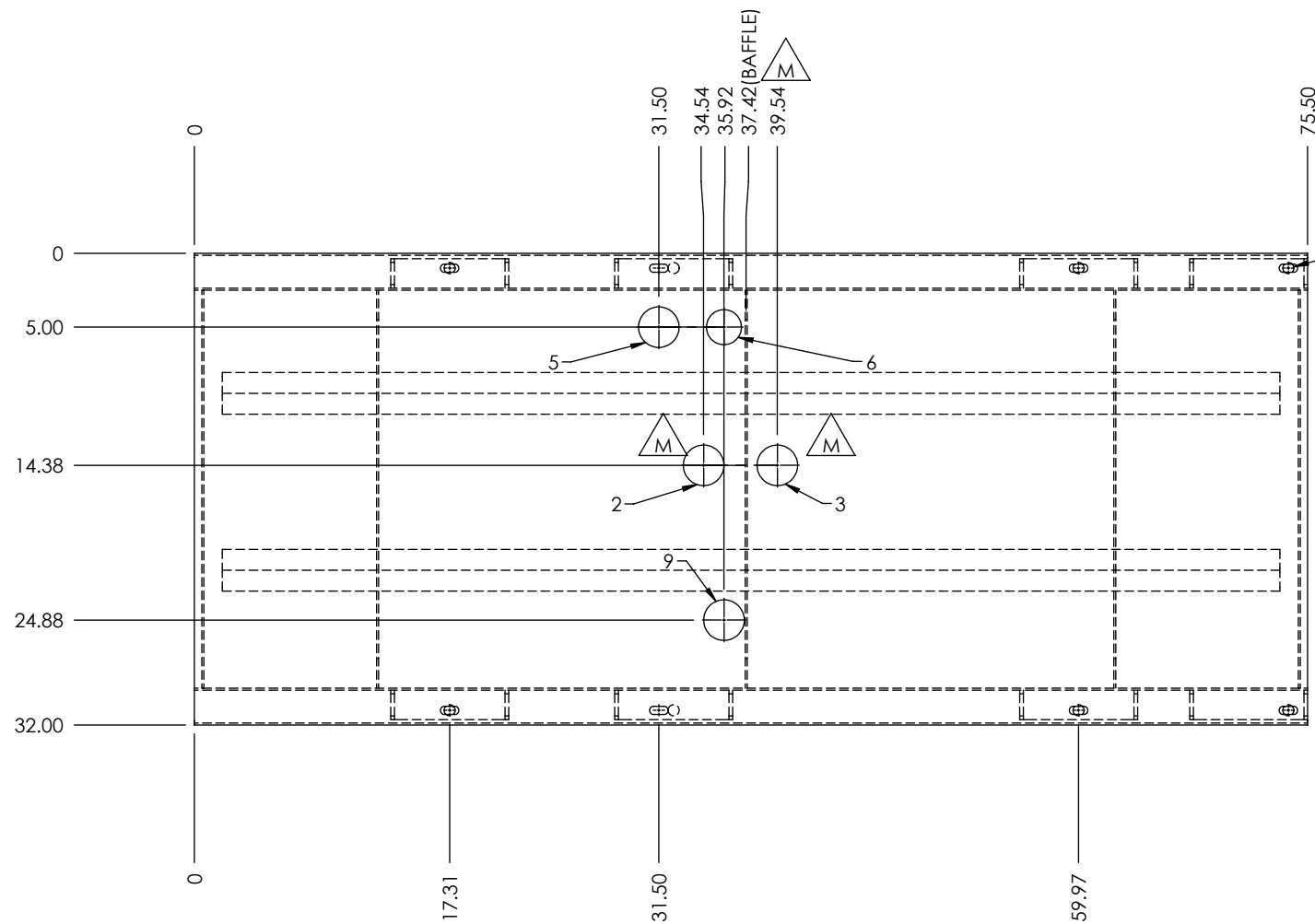

JOB# 16096-02
 PO# 21189
 DUE DATE / /
 OF

APPROVED
 AVIV CHETRIT
 9-JUNE-17

REVISION			
REV.	DESCRIPTION	DATE	APPROVED
M		11/16/11	SJN
C		1/3/12	SJN
D	WELDNUT NOTE CHANGE AND RETURN BEND TO 2.00"	1/16/12	SJN
E	MOVED PORTS A & B	2/27/12	SJN
F	ADDED WELD NUTS	2/28/12	SJN
G	PLUGGED NORMAL VENT	2/29/12	SJN
H	UPDATE REV TO MATCH TRAILER		JJP
I	MOVED WELDNUTS TO INSIDE TANK	1/12/15	JJP
J	INTERNAL REV AT WINCO HAVE NOT SEEN	5/2/16	JJP
K	REMOVED PORT 1 OR "F" WAS 3"NPT	5/2/16	JJP
L	MOVED LEG FOWARD 1"	6/23/16	JJP
M	CHANGED PORTS 2 & 3 TO 2"NPT MOVED PORT 3 TOWARD REAR OF TANK 1" ADJUSTED SIDE SUPPORT/TOP MOUNTING HOLE INTERFACE TO BE COMPATIBLE WITH REV L	6/9/17	TJW

PORT DESCRIPTIONS	
2	2.00 NPT x .50 NPT FUEL SUPPLY W/DIPTUBE
3	2.00 NPT x .50 NPT FUEL RETURN W/DIPTUBE
5	2.00 NPT FUEL FILL W/6" EXTENSION
6	1.50 NPT FUEL GAUGE
9	2.00 NPT PLUGGED

MAY TRIM RETURN BEND TO MAKE WELDING EASIER PER KYLE AND CUSTOMER

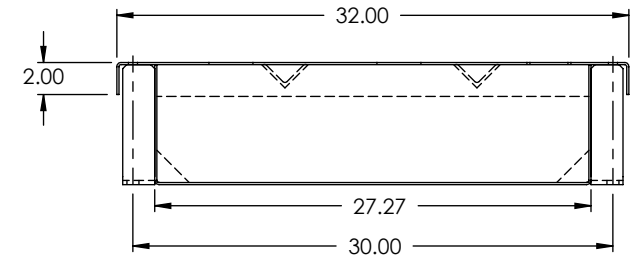
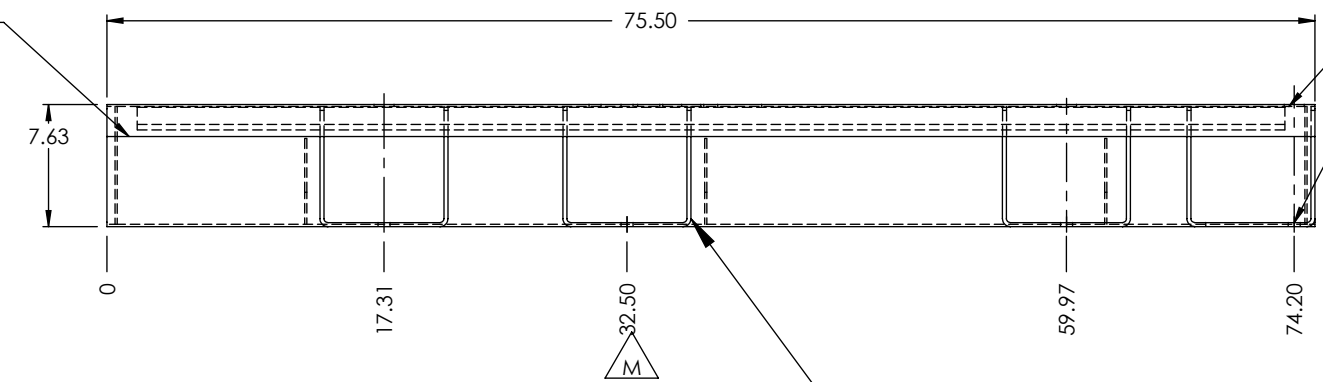

THIS SIDE SUPPORT IS NOT CENTERED ON TOP SLOT

REV	DESCRIPTION	DATE	INIT
INTERNAL REVISIONS			

PROPRIETARY AND CONFIDENTIAL
 THE INFORMATION CONTAINED IN THIS DRAWING IS THE SOLE PROPERTY OF ZIERKE BUILT MFG, INC. ANY RE-PRODUCTION IN PART OR AS A WHOLE WITHOUT THE WRITTEN PERMISSION OF ZIERKE BUILT MFG, INC. IS PROHIBITED.

UNLESS OTHERWISE SPECIFIED:		NAME	DATE
DIMENSIONS ARE IN INCHES	DRAWN	SJN	10/29/2014
TOLERANCES:	CHECKED		
FRACTIONAL ±	ENG APPR.		
ANGULAR: MACH ± BEND ±1°	MFG APPR.		
TWO PLACE DECIMAL ±.12	ZBM REV		
THREE PLACE DECIMAL ±.062			
MATERIAL: ASTM A36 STEEL 10 GA HRS	COMMENTS:	TANK: 75.50L X 27.27W X 7.63H	
FINISH: BLACK PAINT	WEIGHT: 306.49 LBS	10 GA OUTER	

ZBM ZIERKE BUILT MANUFACTURING, INC.
 120 6th AVENUE S E
 WINNEBAGO, MINNESOTA 56098

ZIERKE BUILT MFG

TITLE: TANK ASSY (WIIN-350041-95-1T) SW
 55 GAL
 75.50L X 32.00W X 7.63H

SIZE **B** DWG. NO. (WIIN-350041-95-1T) REV **L**

SCALE: 1:12 DO NOT SCALE DRAWING SHEET 1 OF 2