

029-O

KEY COMPONENTS	
A	ENGINE CONTROL
B	MAIN CB
C	OIL FILL
D	OIL DRAIN
E	OIL DIPSTICK
F	OIL FILTER
G	FUEL FILTER
H	FUEL INLET
I	AIR FILTER
J	COOLANT DRAIN
K	COOLANT FILL
L	AVR
M	BATTERY CHARGER
N	BLOCK HEATER
O	BATTERY

REVISIONS					
REV.	IRN	DESCRIPTION	DATE	BY	APP'D
A	C11141	ORIGINAL	1/25/2023	DRC	

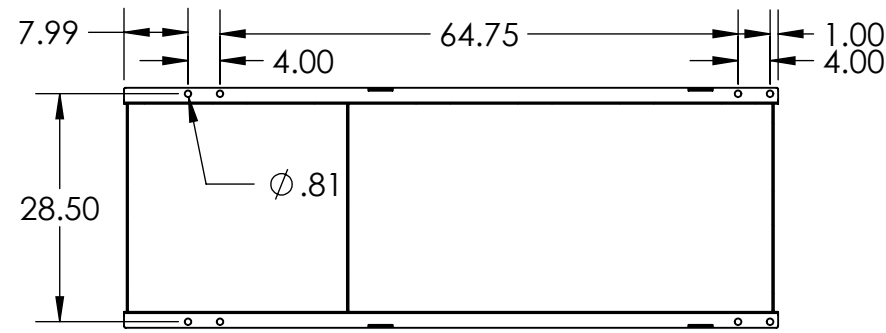

Top View Mounting Holes

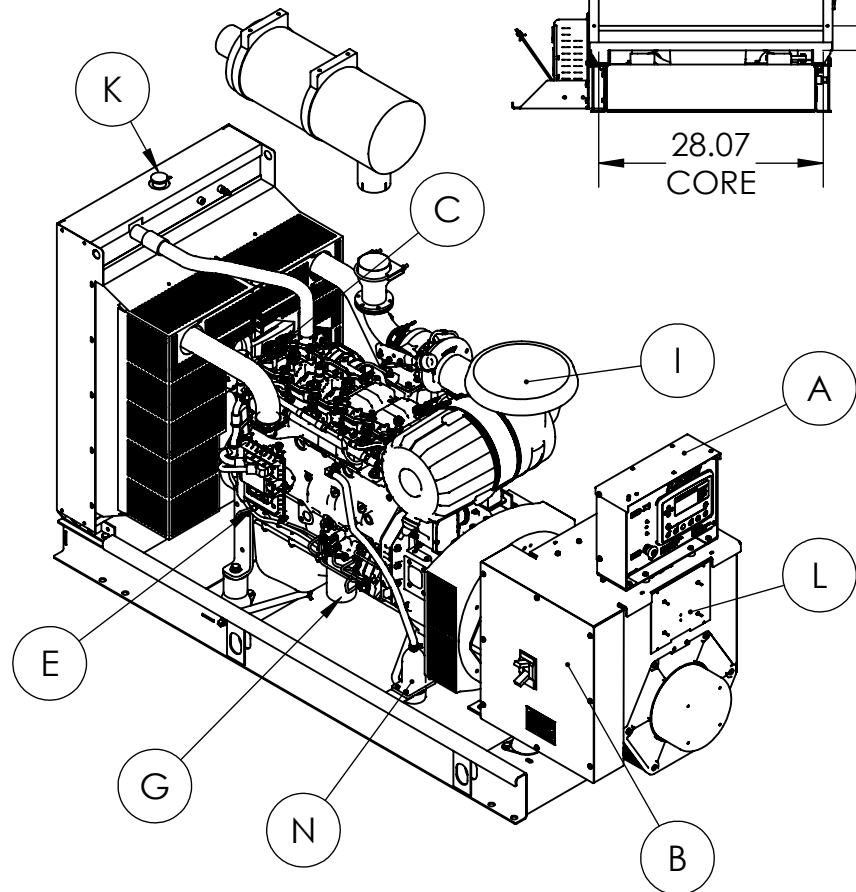
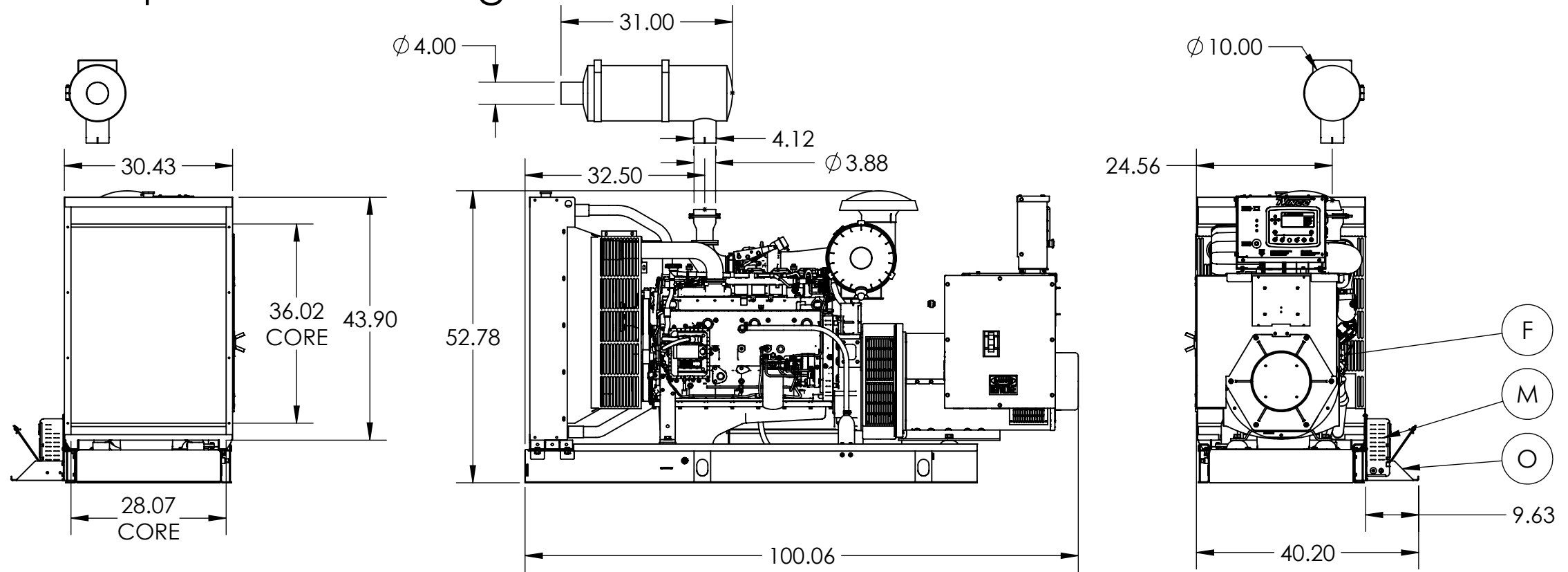

3/8" FUEL HOSE
 APPROXIMATELY 4100LBS
 CONTROLLER CAN BE POSITIONED AT LEFT, BACK OR RIGHT
 BATTERY TRAY IS REMOVABLE TO FURTHER REDUCE WIDTH

THIS DRAWING CONTAINS PROPRIETARY INFORMATION BELONGING TO WINCO. UNAUTHORIZED USE IS PROHIBITED	TOLERANCE:	+/- 0.0625 DECIMAL +/- 1 DEG ANGULAR	TITLE:	DR100-175 NARROW BASE
	WEIGHT:	LBS	PART: O-570	
	MODEL:	DR175 NARROW		
ALL DIMENSIONS INCH ALL WEIGHT POUNDS	WINCO ®			