

689-O

REVISIONS					
REV.	IRN	DESCRIPTION	DATE	BY	APP'D
A	P302	ORIGINAL	11/24/2020	PAK	PAK

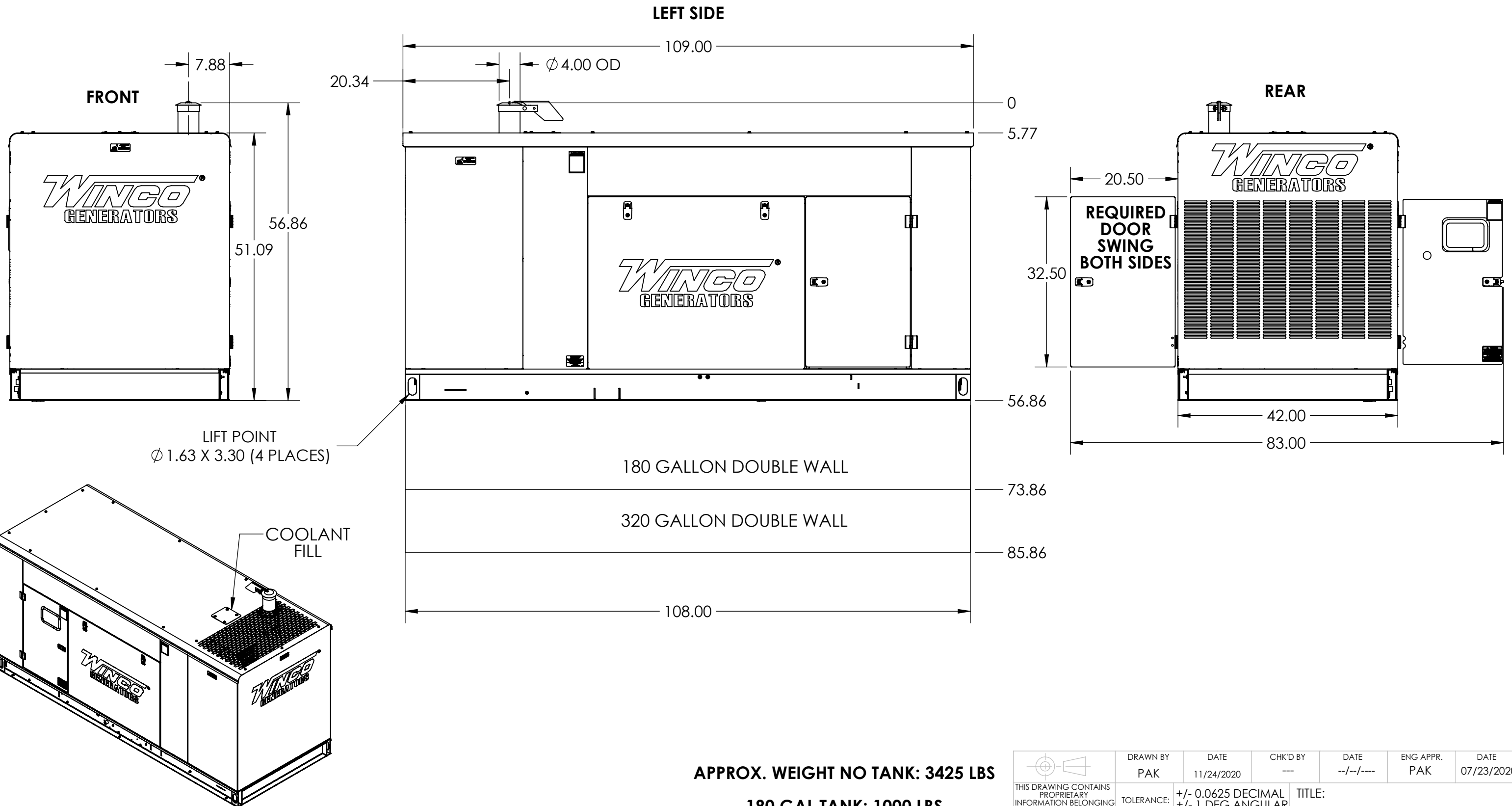

**APPROX. WEIGHT NO TANK: 3425 LBS**

**180 GAL TANK: 1000 LBS**  
**320 GAL TANK: 1300 LBS**

<p>THIS DRAWING CONTAINS PROPRIETARY INFORMATION BELONGING TO WINCO. UNAUTHORIZED USE IS PROHIBITED.</p> <p>ALL DIMENSIONS INCH</p>	DRAWN BY	DATE	CHK'D BY	DATE	ENG APPR.	DATE
	PAK	11/24/2020	---	--/------	PAK	07/23/2020
	TOLERANCE:	+/- 0.0625 DECIMAL		TITLE:		
	MODEL:	+/- 1 DEG ANGULAR		OUTLINE DRAWING		
	DR35 - DR65	WINGCO®		PART:	O-539	1 of 2

REVISIONS

REV.	IRN	DESCRIPTION	DATE	BY	APP'D
A	P302	ORIGINAL	11/24/2020	PAK	PAK

639-O

KEY COMPONENTS

A	ENGINE CONTROL
B	MAIN LINE CIRCUIT BREAKER
C	OIL FILL
D	OIL DRAIN
E	OIL DIPSTICK
F	OIL FILTER
G	FUEL FILTER
H	FUEL INLET
I	AIR FILTER
J	COOLANT DRAIN
K	COOLANT FILL
L	AVR
M	BATTERY CHARGER
N	BLOCK HEATER
O	BATTERY

TOP VIEW HOLE PATTERN

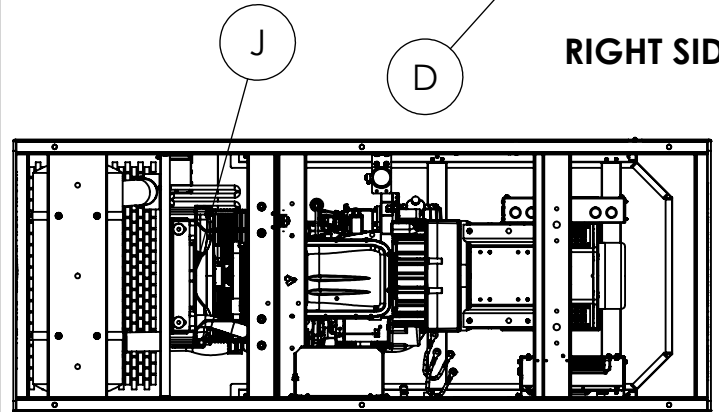
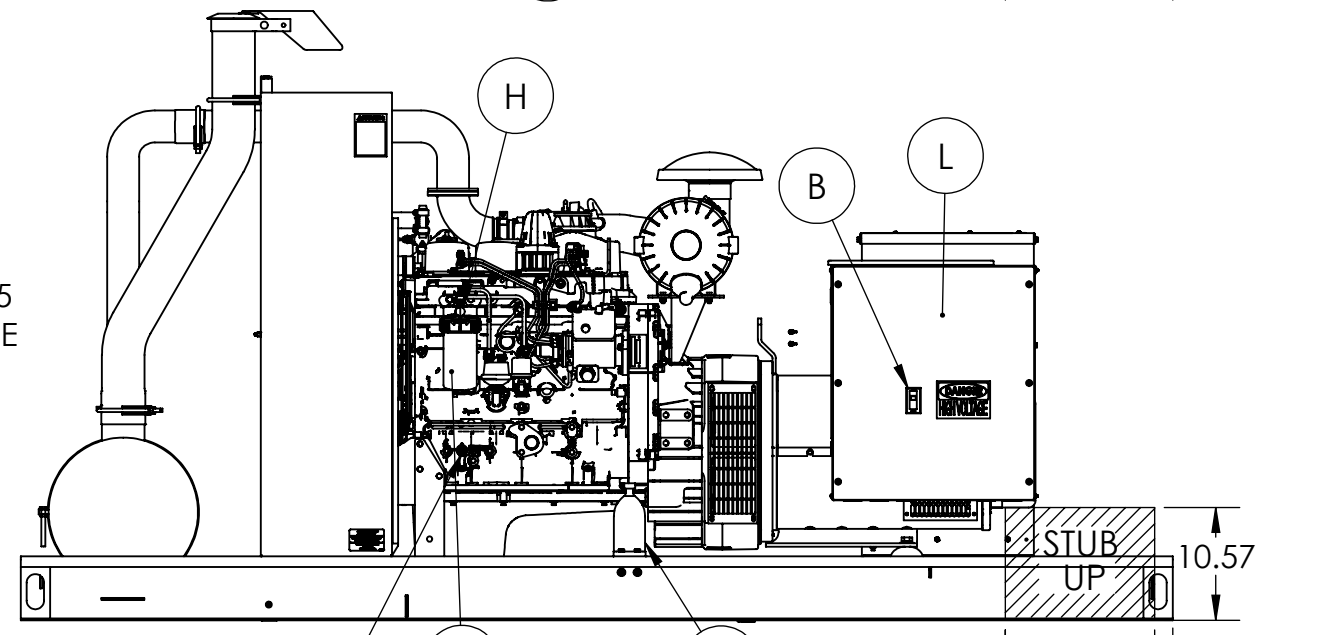
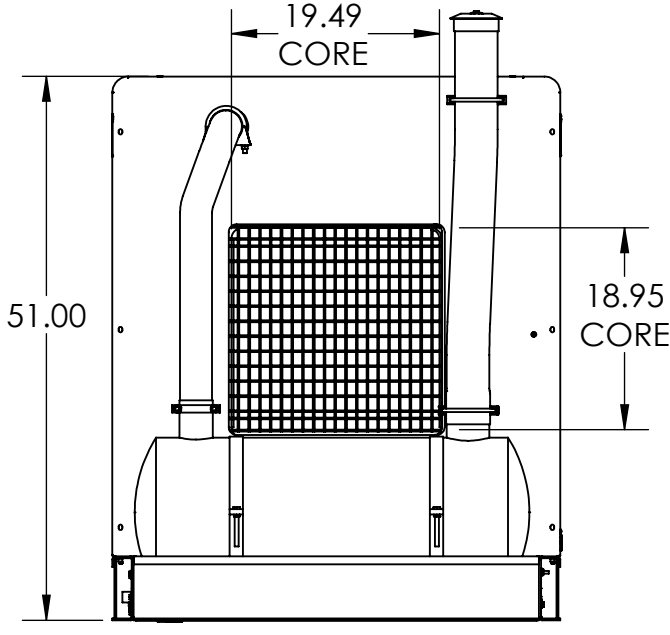
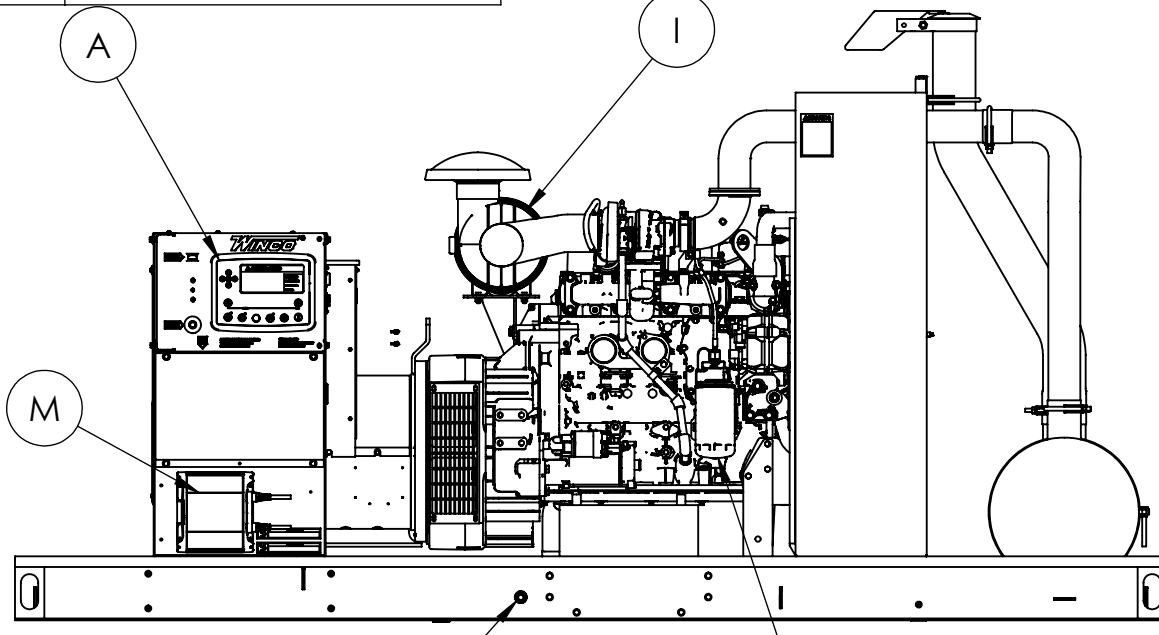
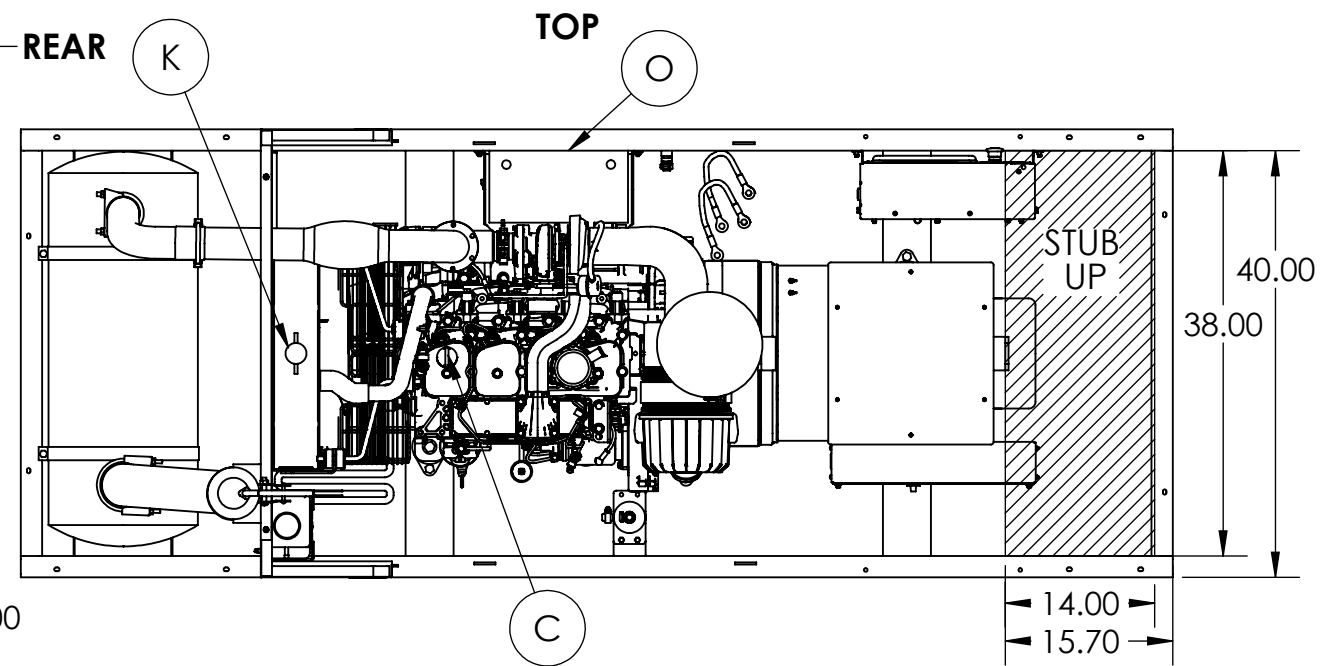
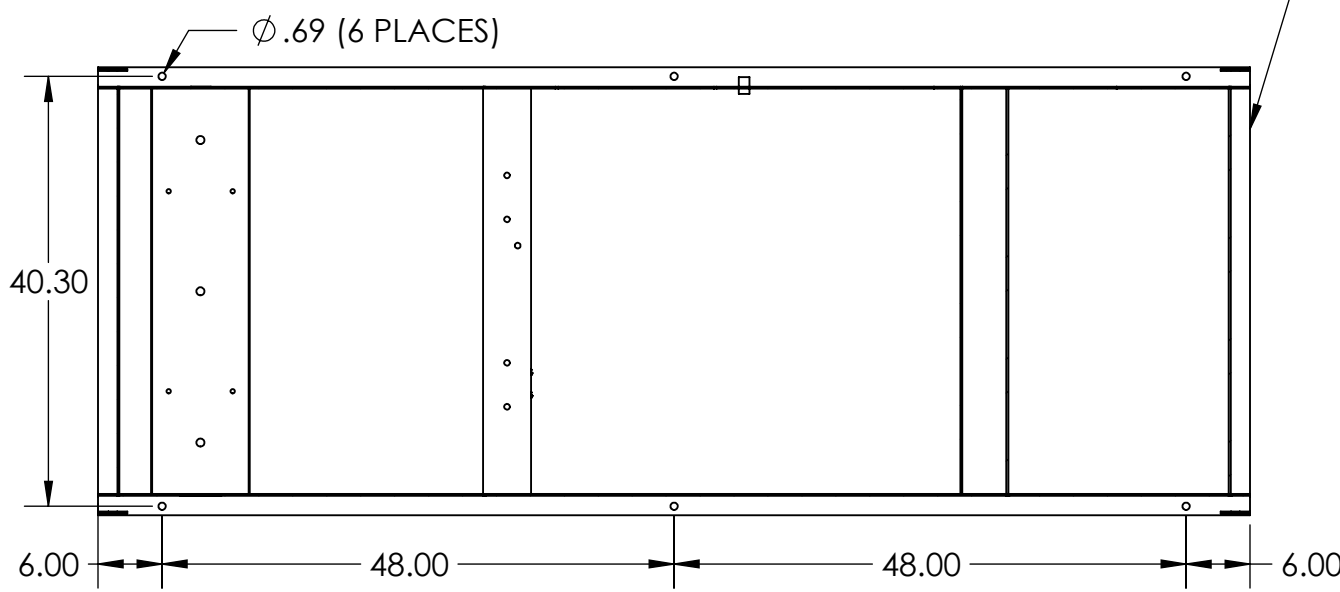

3/8 FUEL HOSE

 THIS DRAWING CONTAINS PROPRIETARY INFORMATION BELONGING TO WINCO. UNAUTHORIZED USE IS PROHIBITED. ALL DIMESNIONS INCH	DRAWN BY	DATE	CHK'D BY	DATE	ENG APPR.	DATE
	TDS	6/16/2020			PAK	07/23/2020
	TOLERANCE:	+/- 0.0625 DECIMAL		TITLE: OUTLINE DRAWING		
	MODEL:	DR35 - DR65		PART: O-539 2 of 2		

