

O-513

REVISIONS					
REV.	IRN	DESCRIPTION	DATE	BY	APP'D
A	C2783	ORIGINAL	10/22/2015	SCN	ZJF
B	DR300	UPDATED OUTLINE DRAWING STANDARDS	12/23/2020	MCB	DRC

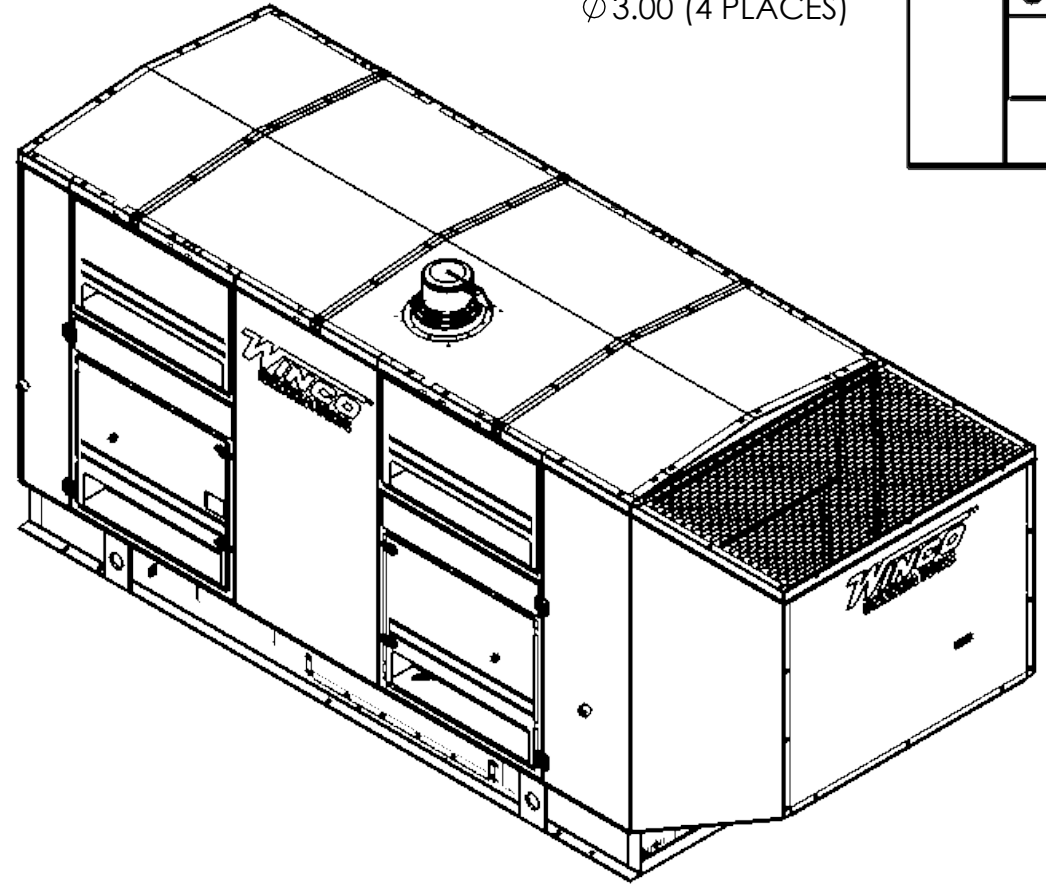
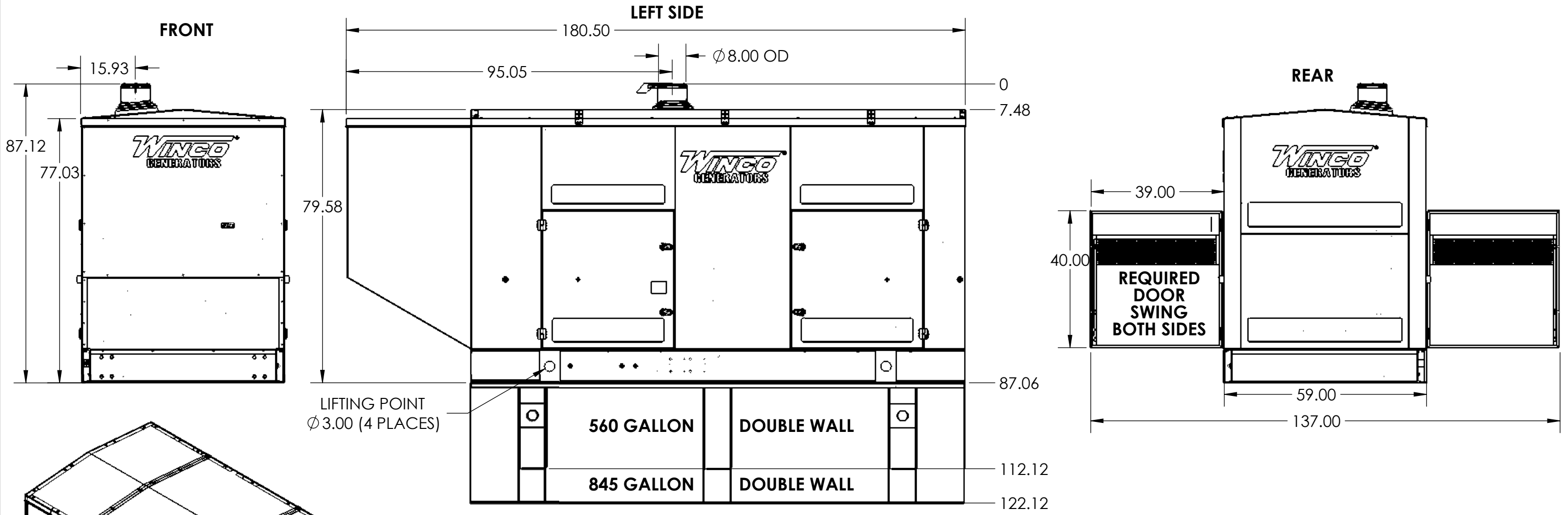

APPROX. WEIGHT NO TANK: 8945 LBS

**560 GAL TANK: 2500 LBS
 845 GAL TANK: 2600 LBS**

 THIS DRAWING CONTAINS PROPRIETARY INFORMATION BELONGING TO WINCO. UNAUTHORIZED USE IS PROHIBITED. ALL DIMENSIONS INCH	DRAWN BY PAK	DATE 11/24/2020	CHK'D BY ---	DATE --/------	ENG APPR. PAK	DATE 07/23/2020
	TOLERANCE: +/- 0.0625 DECIMAL +/- 1 DEG ANGULAR	TITLE: OUTLINE DRAWING				
	MODEL: DR350	PART: O-513				



019-O

KEY COMPONENTS

A	ENGINE CONTROL
B	MAIN LINE CIRCUIT BREAKER
C	OIL FILL
D	OIL DRAIN
E	OIL DIPSTICK
F	OIL FILTER
G	FUEL FILTER
H	FUEL INLET
I	AIR FILTER
J	COOLANT DRAIN
K	COOLANT FILL
L	AVR
M	BATTERY CHARGER
N	BLOCK HEATER
O	BATTERY

TOP VIEW HOLE PATTERN

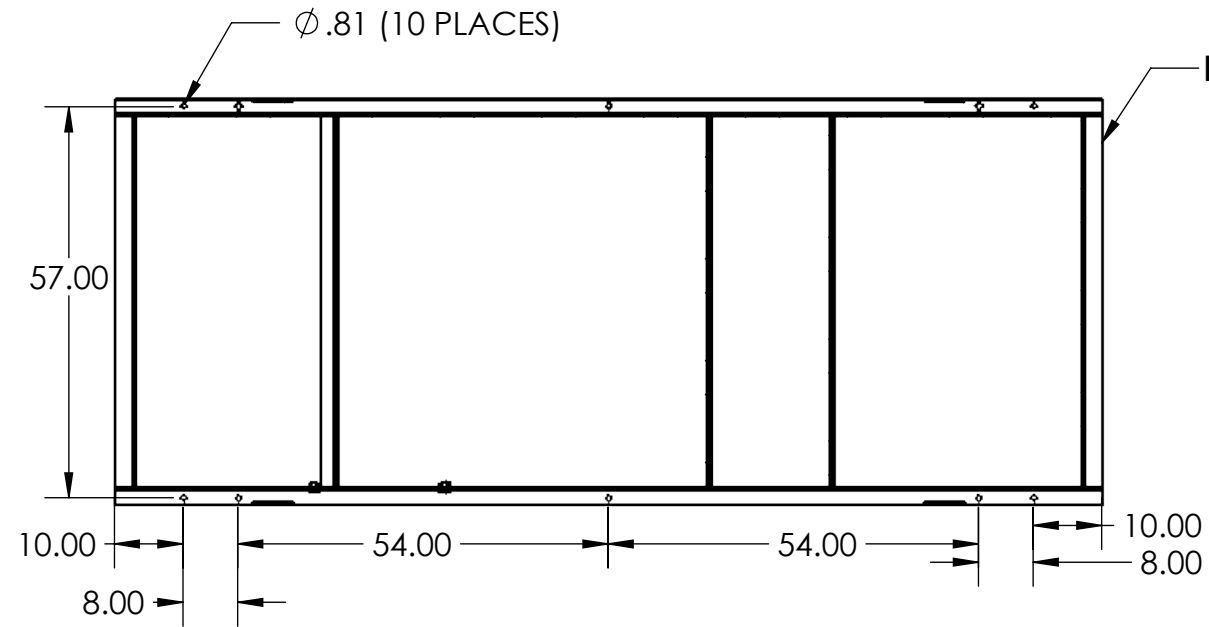

REVISIONS					
REV.	IRN	DESCRIPTION	DATE	BY	APP'D
A	C2783	ORIGINAL	10/22/2015	SCN	ZJF
B	DR300	UPDATED OUTLINE DRAWING STANDARDS	12/23/2020	MCB	DRC

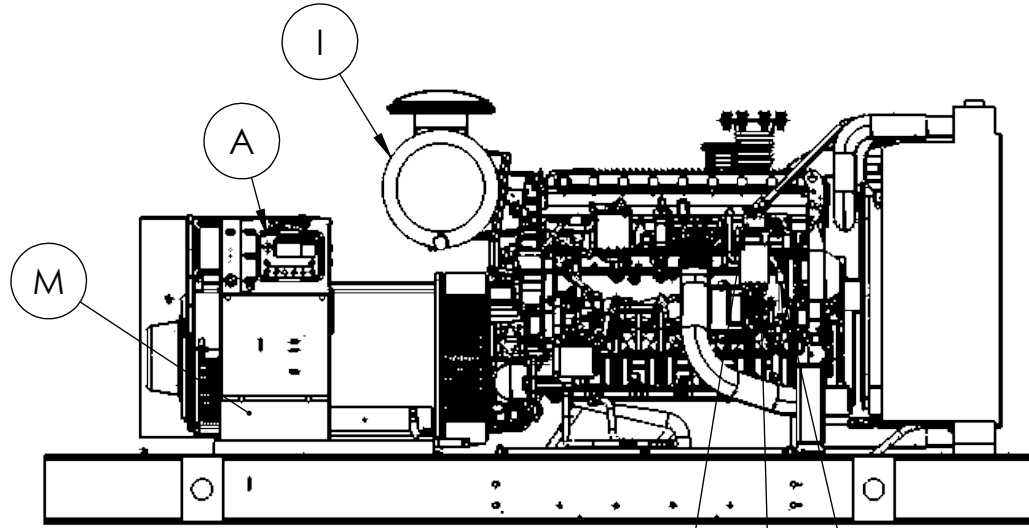
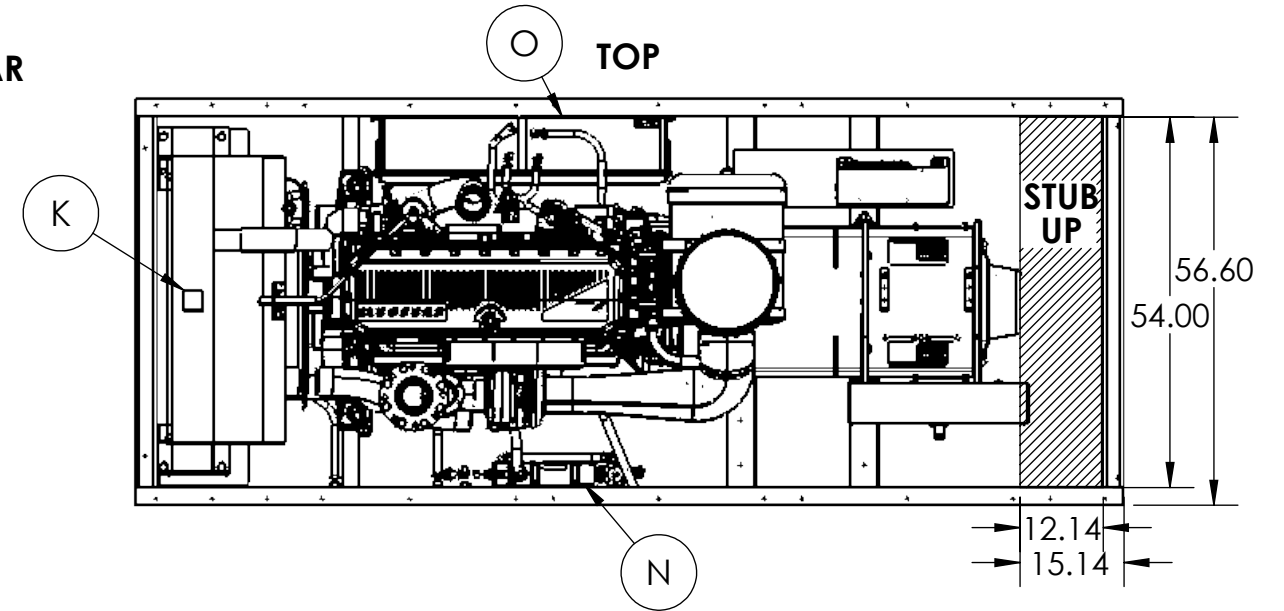

RIGHT SIDE

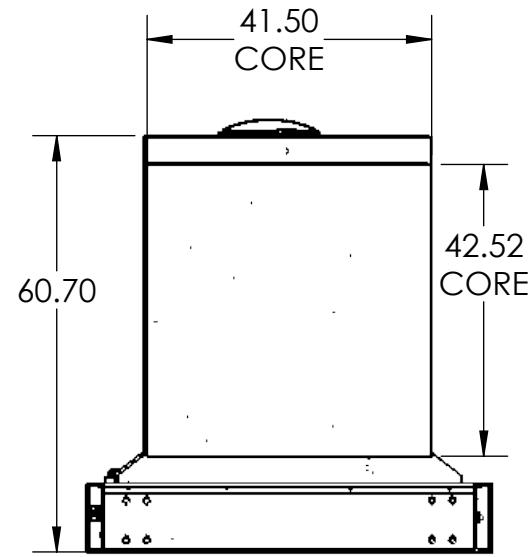

FRONT

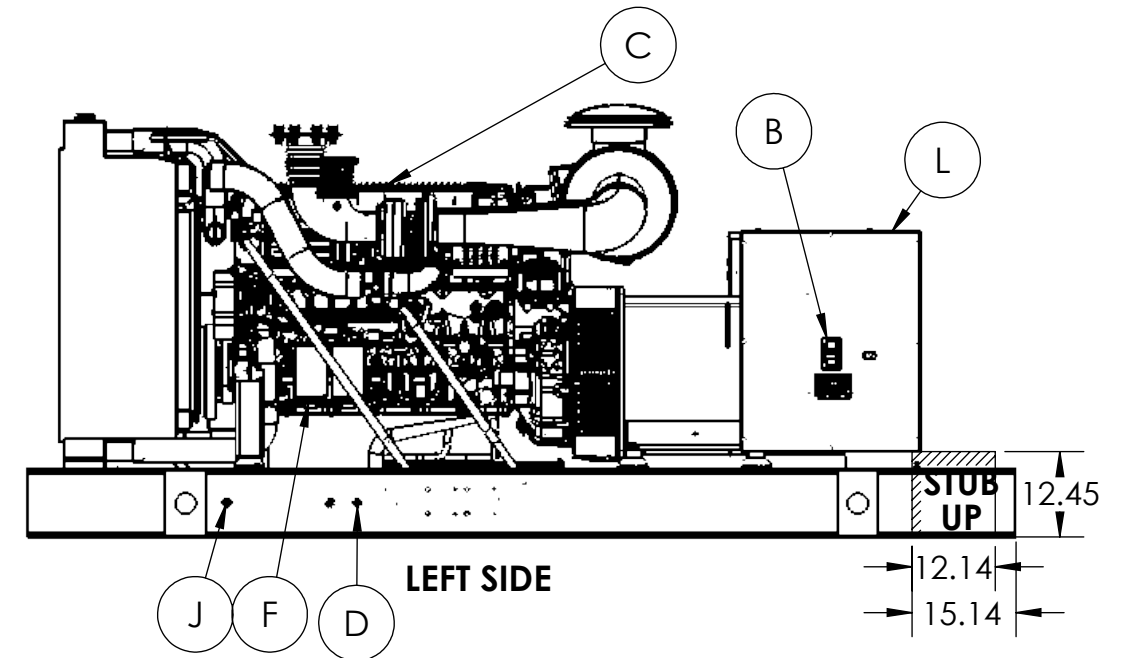

LEFT SIDE

3/8 FUEL HOSE

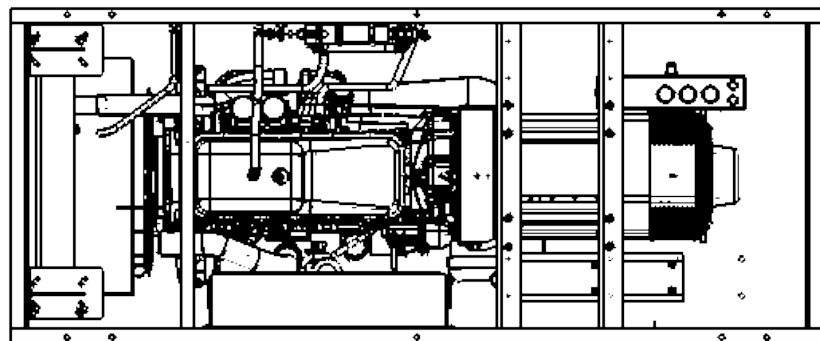

BOTTOM

<p>THIS DRAWING CONTAINS PROPRIETARY INFORMATION BELONGING TO WINCO. UNAUTHORIZED USE IS PROHIBITED.</p> <p>ALL DIMENSIONS INCH</p>	DRAWN BY	DATE	CHK'D BY	DATE	ENG APPR.	DATE
	TDS	9/2/2020			PAK	07/23/2020
	TOLERANCE:	+/- 0.0625 DECIMAL		TITLE:		
	MODEL:	+/- 1 DEG ANGULAR		OUTLINE DRAWING		
	DR350	PART:		O-513		2 of 2

