

WINPOWER

HEAVY DUTY GENERATORS

OPERATOR INSTRUCTION MANUAL

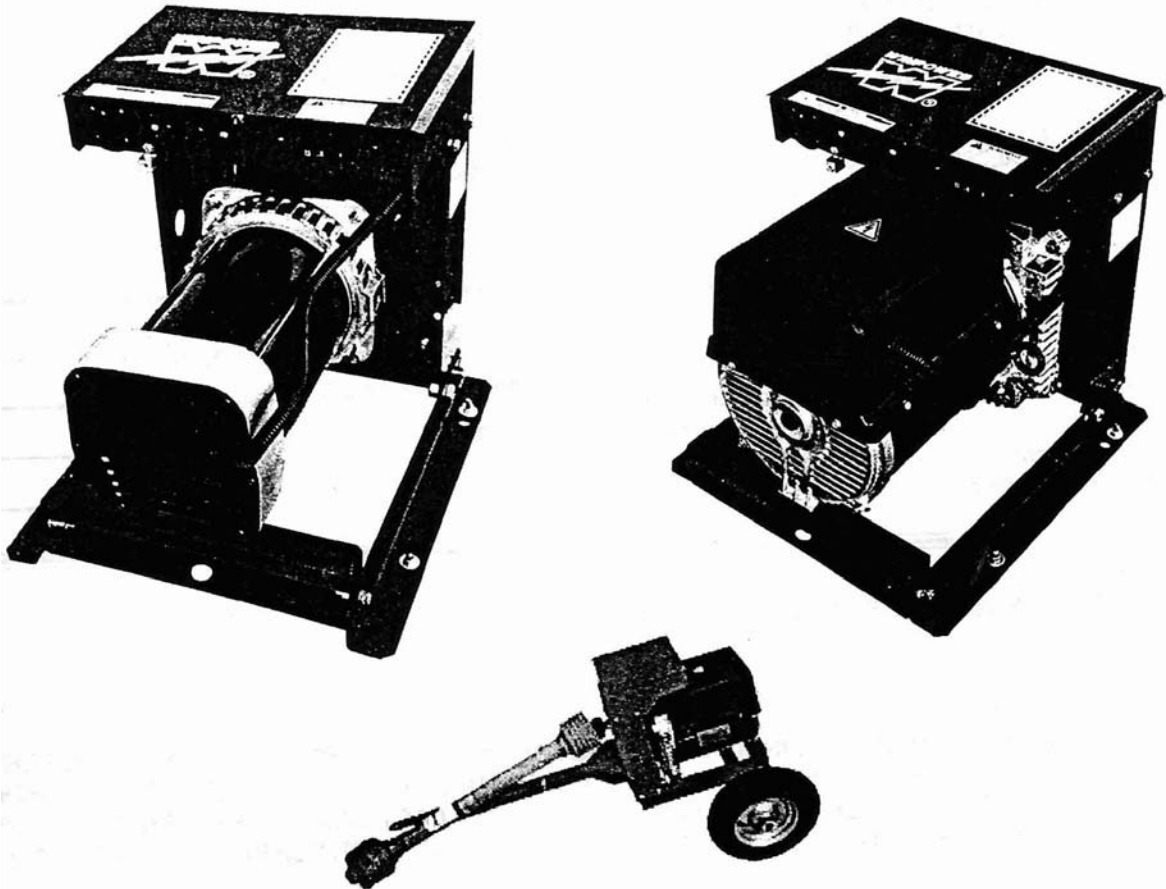

COMPACT SERIES TRACTOR DRIVE ALTERNATORS

**MODELS
10/7PTCD
14/11PTCD
18/15PTCD**

P.O. Box 495
St. Peter, MN 56082
Phone: 507-357-6700
Fax: 507-357-6580



TABLE OF CONTENTS	
INTRODUCTION	1
SAFETY INFORMATION	1
FOUNDATION MOUNTING	2
TRAILER MOUNTING	3
LOAD DISCONNECT PLUG INSTALLATION	3
OPERATING THE ALTERNATOR	3
MAINTENANCE REQUIREMENTS	4
OPERATION OF TRACTOR DRIVEN ALTERNATOR	4
PROCEDURE FOR USE	5
PTO ALIGNMENT	5
LUBRICATION	5
TESTING OF RECTIFIERS	6
HANDLING PROCEDURES FOR RECTIFIER DIODES	6
TESTING STATOR	6
WINDING RESISTANCES	6
SERVICE DIAGNOSIS	7
10/7PTCD COMPLETE UNIT ASSEMBLY ILLUSTRATION	8
14/11PTCD AND 18/15PTCD COMPLETE UNIT ASSEMBLY ILLUSTRATION	9
RECEPTACLE PANEL ASSEMBLY ILLUSTRATION (ALL MODELS)	10
ELECTRICAL CONNECTIONS	11
TWO WHEEL TRANSPORT	12
WINPOWER LIMITED WARRANTY	13

Copy your model and serial number here. No other Winpower generator has the same serial number as yours. It is important that you record the number and other vital information here. If you should ever need to contact us about this unit it will help us to respond to your needs faster.

MODEL _____
 SERIAL NUMBER _____
 PURCHASE DATE _____
 DEALER _____

CAUTION
 FOLLOW THE INSTRUCTIONS IN THE OWNER'S MANUAL SPECIFICALLY WHEN PUTTING THIS ALTERNATOR INTO SERVICE.

IMPORTANT
 ALL STANDBY POWER PLANTS INCLUDING TRACTOR DRIVEN ALTERNATORS SHOULD BE PERIODICALLY EXERCISED. FOR PROPER MAINTENANCE OF YOUR TRACTOR DRIVEN ALTERNATOR, IT SHOULD BE OPERATED FOR ONE HOUR CARRYING RATED LOAD AT LEAST TWICE A YEAR. THIS WILL ASSURE THAT YOUR ALTERNATOR IS IN OPERATING CONDITION AND READY FOR USE WHEN AN EMERGENCY CONDITION DEVELOPS.

PARTS LIST, PARTS DRAWINGS, AND WIRING DIAGRAM PERTAINING TO YOUR UNIT ARE ENCLOSED WITH THIS MANUAL.

This manual covers the latest compact portable tractor driven Power Take Off (PTO) generator set models from WinPower. The three models range from 7,000 to 15,000 watts, and are designed to provide 120/240V single phase electrical power for standby and utility service when commercial power disrupted, inaccessible or impractical. All of these small PTO units have cast iron gear cases with a 1-3/8" - 6 spline, 540 rpm input shafts and brushless, heavy-duty 3600 rpm, 2 pole, low waveform distortion generators. The models covered by this manual are listed in the following table with their basic specifications and details.

These compact PTO series heavy duty generator units are designed to provide reliable electrical power for customers who already have a compact utility tractor with 12 to 40 horsepower and a 540 rpm PTO shaft. The PTO unit is a cost-effective way of providing needed electrical power without the cost or added maintenance of a dedicated drive engine. Primary applications for these PTO series are for infrequent or medium duty loads where the unit will normally be operated less than 50 to 100 hours per year. Typical uses might be for farm, ranch or home standby or portable field power away from convenient utility or where running an extension cord is impractical. The compact PTO series units are built to last, but are not intended for prime power (continuous or sole source) applications.

All PTO units have a full control panel with features like large voltmeter, mainline circuit breaker, convenience and full load 4-wire receptacles. The full load matching plug is also included for customers load connection cord set. Traditional WinPower power, convenience and reliability are standard features of this new series of compact PTO generators.

FEATURES BY MODEL							
TRACTOR PTO HP	INPUT SHAFT	GEAR LUBE	MOTOR ** STARTING	WATTS MAX/RATED	AMPS @ 120/240V	FEATURES*	
10/7PTCD	20/14	1-3/8 6SPL	16 OZ	4 HP	10,000/7,000	45 / 30	1, 2, 3, 4, 5, 6, 7
14/11PTCD	28/22	1-3/8 6SPL	16 OZ	6 HP	14,000/11,000	62 / 45	1, 2, 3, 4, 5, 6, 7
18/15PTCD	36/30	1-3/8 6SPL	16 OZ	8 HP	18,000/15,000	83 / 60	1, 2, 3, 4, 5, 6, 7

**MOTOR STARTING – CODE ‘G’ CAPACITOR START –
*FEATURES – LISTED BELOW BY REFERENCE NUMBER WITH EXPLANATION –

1 – Brushless, low harmonic design with skewed rotor and damper windings for minimal load noise
2 – Capacitive excitation for close regulation and high motor starting
3 – Dual voltage - 120/240 volt output
4 – 4 wire Load connection plug for convenient full load 120/240 volt output cordset
5 – 15Amp duplex convenience receptacle
6 – Large face Voltmeter for setting speed and monitoring power output voltage level

INTRODUCTION

The words generator and alternator are used interchangeably but have the same meaning.

This manual covers standby generators driven by the power take-off of a compact tractor. These generators use a capacitor excitation system. All generators are carefully inspected, tested and packaged for shipment at the factory. The generator should be unpacked as early as possible upon receipt and inspected for damage which may have occurred during shipment. Any damage noted should be promptly reported to the carrier in order that a claim can be filed to recover the cost of the damage. If at all possible, this damage should be noted on the freight bill at the time of delivery. If the damage appears to be of a major nature, the generator should not be operated until the fault has been corrected.

Tractor driven generators are designed to deliver voltage and current similar to that of the normal power line. Equipment that can be operated on normal power can also be operated by the generator, provided that the capacity of the generator is not exceeded. It should be remembered that the power line, for all practical purposes, is backed by an unlimited generator.

When not in use the generator should be stored in a clean dry location. All types of mechanical equipment suffer from long periods of storage without use. The generator should be used at frequency intervals to prevent deterioration and detect possible fault before an emergency condition develops.

SAFETY INFORMATION

This generator set has been designed and manufactured to allow safe, reliable performance. Poor maintenance, improper or careless use can result in potential deadly hazards; from electrical shock, exhaust gas asphyxiation, or fire. Please read all safety instructions carefully before installation or use. Keep these instructions handy for future reference. Take special note and follow all warnings on the unit labels and in the manuals.

ANSI SAFETY DEFINITIONS

DANGER:

DANGER indicates an imminently hazardous situation which, if not avoided, will result in death or serious injury. This signal word is to be limited to the most extreme situations.

WARNING:

WARNING indicates a potentially hazardous situation which, if not avoided, could result in death or serious injury.

CAUTION:

CAUTION indicates a potentially hazardous situation which, if not avoided, may result in minor or moderate injury. It may also be used to alert against unsafe practices.

NOTE:

CAUTION is also used on the unit labels and in this manual to indicate a situation that could result in serious damage or destruction of the equipment and possible personal injury.

1. **ELECTRIC SHOCK** - The output voltage present in this equipment can cause a fatal electric shock. This equipment must be operated by a responsible person.

- a. Do not allow anyone to operate the generator without proper instruction.
- b. Guard against electric shock.
- c. Avoid contact with live terminals or receptacles.
- d. Use extreme care if operating this unit in rain or snow.
- e. Use only three-prong grounded plugs and extension cords.
- f. Be sure the unit is properly grounded to an external ground rod driven into the earth.
- g. Do not make or break electrical connection under load.

2. **FIRE HAZARD** - Gasoline, diesel and other fuels always present a hazard of possible explosion and/or fire.

- a. Keep a fire extinguisher nearby and know its proper use. Fire extinguishers rated ABC by NFPA are appropriate.

3. **DEADLY EXHAUST GAS** - Exhaust fumes from any engine contain carbon monoxide, an invisible, odorless and deadly gas that must be mixed with fresh air.

- a. Operate only in well ventilated areas.
- b. Never operate indoors.

4. **NOISE HAZARD** - Excessive noise is not only tiring, but continual exposure can lead to loss of hearing.

- a. Use hearing protection equipment when working around this equipment for long periods of time.
- b. Keep your neighbors in mind when permanently installing this equipment.

5. **CLEANLINESS** - Keep the generator and surrounding clean.

- a. Remove all grease, ice, snow or materials that create slippery conditions around the unit.
- b. Remove any rags or other material that could create potential fire hazards.

6. **SERVICING EQUIPMENT** - All service, including the installation or replacement of service parts, should be performed only by a qualified technician.

- a. Use only factory approved replacement parts.
- b. Do not work on this equipment when fatigued.
- c. Use extreme caution when working on electrical components. High output voltages from this equipment can cause serious injury or death.
- d. Always avoid hot mufflers, exhaust manifolds, and engine parts. They all can cause severe burns instantly.

7. **INSTALLATION** - Installing an isolation power transfer switch and PTO generator is not a typical "do-it-

yourself" project. Consult a qualified, licensed electrician or contractor. The installation must be safe and comply with all national, state, and local codes. See page 11.

- a. Never operate the PTO drive generator without having it properly mounted to a concrete base or approved trailer.
- b. Never connect the PTO generator to an existing electrical system without installing an isolation transfer switch.
- c. Always insure the drive shaft is straight and level before operating the generator.

8. **OPERATION** - PTO drive shafts (tumbling bars) have many inherent dangers, extreme caution must be exercised when using them.

- a. **NEVER** allow children around a drive shaft when it is in operations.
- b. Keep all safety guards and shields in place and securely tightened.
- c. Never operate a drive shaft that has been damaged or had the safety shield removed.
- d. Never step over a drive shaft while it is running.
- e. Never wear a necktie, loose articles of clothing, or anything else that can be caught in moving parts.
- f. Never try to stop a turning drive shaft with your hand or your foot.

INSTALLATION

FOUNDATION MOUNTING

Mount the generator on a foundation if it is to be used as a permanent or standby power source. See "TRAILER MOUNTING" if generator will be used as a portable power source (Figure 1). When planning a foundation consider the following points:

A. The foundation location should enable aligning the drive shaft (tumbling bar) in a straight or nearly straight line between the power take-off and the generator input shaft. Misalignment must be less than 10 degrees during generator operation, even though the mechanical design of the tumbling bar would allow greater misalignment.

B. The foundation must be solid enough to absorb generator starting and reflected load torque during operation.

C. The foundation surface should be flat.

D. Space is required around the generator for mounting switching devices, making connections, and for servicing.

E. All four generator mounting pads must rest firmly on the foundation. Install shims if necessary to even out the foundation under the mounting pads then bolt the generator firmly in place.

TRAILER MOUNTING

Mount the generator on a trailer if you plan to use it as a portable power source. See Figure 1. When selecting or building a trailer to mount the generator, consider the following points:

A. The trailer construction must be strong enough to support the generator.

B. The design of the trailer must enable the trailer to remain stable during operation, and to resist tipping caused by generator starting and reflected load torque.

WARNING: Personal Injury & Equipment Damage
TRAILER MAY TIP OVER AND CAUSE INJURIES IF
WHEELS ARE NOT SPACED FAR ENOUGH APART.

C. The trailer height and mounting position of the generator on the trailer should enable aligning the drive shaft (tumbling bar) in a straight or nearly straight line between the power take-off and generator input shafts. Misalignment must be less than 10 degrees during generator operation, even though the mechanical design of the tumbling bar would allow greater misalignment.

D. The generator mounting area of the trailer bed should be flat.

All four generator mounting pads must rest firmly on the trailer bed. Install shims if necessary to even out the bed under the mounting pads, then bolt the generator firmly in place.

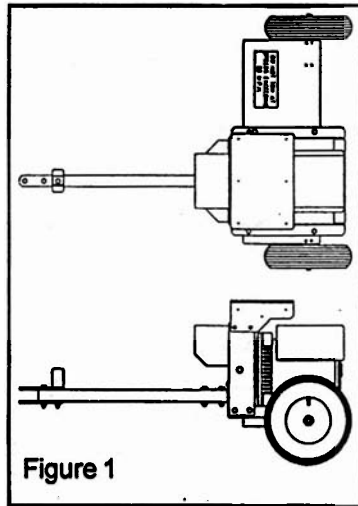

Figure 1

Assembly

The only assembly work required after unpacking the generator is to assemble and wire the load disconnect plug, which is packed in the generator carton.

WARNING: Personal Injury
DISCONNECT POWER BEFORE WIRING

IMPORTANT: Use copper wire only. Do not tin conductors. Sizing cable - see NEC 400-5.

CORD SIZE: #10/4 SJ to #4/4 SO, 1.25 inch dia. max.

10/7PTCD uses	#10/4	4 conductor cord
14/11PTCD uses	#6/4	4 conductor cord
18/15PTCD uses	#4/4	4 conductor cord

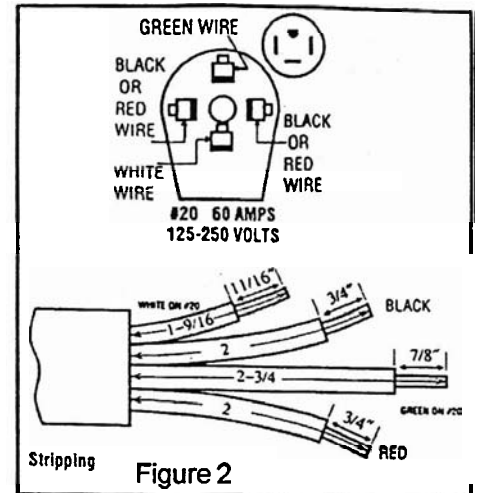

Figure 2

To assemble and wire the load disconnect plug, proceed as follows:

1. Strip outer jacket 2-3/4".
2. Cut and strip leads to lengths specified for the particular plug.
3. Disassemble cable clamp and top cover.
4. Remove one blade at a time, insert the stripped end of the appropriate colored wire designated above, and tighten the set screw.
5. Fit blades through slots in bottom cover and push down until home. Please note: Make sure blades are in correct slots and oriented in accordance with the diagram above or you will not be able to close the top cover fully.
6. Place top plastic cover over assembly and partially tighten the bakelite assembly screw. Realign blades straight (so they fit into the top bakelite housing properly) and tighten the assembly screw.
7. Assemble cable clamp over the outer jacket of the wire and tighten the two clamp screws.

Special Note: For small size round (less than 3/4") and flat cables, the wire clamp may be inverted.

WARNING: Failure to wire as instructed may cause personal injury or damage to device or equipment. To be installed or checked by an electrician or qualified person only.

OPERATING THE ALTERNATOR

WARNING: Personal Injury

When working on or around these generators, do not wear loose fitting clothing or any articles that may get caught in moving parts.

A properly rated and installed double throw manual power isolation transfer switch must be used with a standby generator. The transfer switch isolates the load from the power line and allows you to safely operate your loads without endangering the power line repair crew. See page 11.

The load, connected to the normal terminals of the transfer switch, is energized by the normal power line

when the switch is in the normal position. The generator, connected to the emergency terminals of the switch, furnishes power when the switch is in the emergency mode position.

When the normal power fails, the generator is attached to the tractor by means of the power take-off shaft.

WARNING: Personal Injury

Be sure the safety shields are in place and retained.

Start the tractor and adjust the speed until the pointer of the voltmeter on the generator panel registers on the high side of the green portion of the color band.

Check the connected load to assure that all heavy electrical equipment is disconnected.

Move the transfer switch handle to the emergency position connecting the load to the generator.

Switch on all required electrical equipment within rated capacity of the generator maintaining tractor speed to cause the voltmeter to remain in the green portion of the color band.

NOTE: Equipment Damage

If the load includes motors turn them on one at a time, highest starting current motor first, next highest second, etc.

If the circuit breaker of the generator control panel trips during operation, the connected load is greater than the rated generator capacity.

Reduce the load by disconnecting any nonessential equipment during emergency conditions and reset the breaker to resume power feed.

When the normal commercial power is restored, for at least 15 minutes without interruption, the transfer switch can be returned to the normal position and the tractor drive generator shut down. Reduce speed gradually to minimize stress in drive line.

If the generator is mounted on an off-highway trailer, such as the Winpower TDM/75, it should be stored in a garage, barn or machine shed in a dry and clean location. The generator should be covered with a tarpaulin to prevent the entrance of dust, chaff, and/or moisture.

The generator may be stored on end, provided the generator is on a clean, dry elevated surface such as a board.

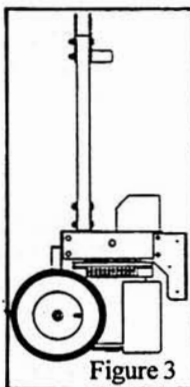

Do not have it resting on a dirt surface. (Figure 3)

MAINTENANCE REQUIREMENTS

1. Maintain proper oil level in the PTO gear case. See page 5 for list of recommended vendors. Do not overfill, maintain level to the center of clear site gauge, approximately four (4) inches from the bottom of the gear case on the right side (Figure 4).

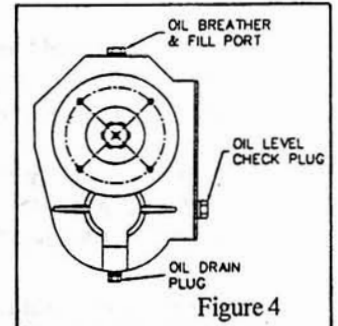

CAUTION: Equipment Damage

Do not overfill generator gear case. Overfilling causes overheating and oil seal failure.

2. Inspect for loose or broken wiring connections.

Make sure that wiring connections are not loose at the generator end, circuit breakers, and receptacles.

3. Do not allow dirt or chaff to collect in the interior of the generator or the ventilation openings. Inspect for indication of the entrance of mice or insects into the generator. The inlet and outlet openings are louvered, but possible damage to the louvers could occur. Mice can destroy the generator winding.

WARNING: Equipment Damage

DO NOT CLEAN THE GENERATOR WHILE IT IS RUNNING.

CAUTION: Equipment Damage

Most electrical equipment in North America operates satisfactorily at frequencies between 59 and 61 Hz (cycles per second). Operating the generator at frequencies outside that range may cause damage to the generator and/or to electrical equipment driven by the generator.

OPERATION OF TRACTOR DRIVEN ALTERNATORS

When the alternator is not in use, it must be maintained in a clean and dry condition. The inside of the panel, frame and air inlet and outlet must be free from dirt, chaff, and moisture (including condensation). When connection is made at the meter pole, a double throw manual isolation power transfer switch must be used. Normal power is connected to the top, the load at the center, and the alternator at the bottom of the switch. **Warranty is void if an isolation transfer switch is not used** (check instruction manual on transfer switch.)

PROCEDURE FOR USE

1. Set the manual transfer to mid or normal (up) position.
2. Connect the power take-off shaft securely to the alternator and the tractor. Position as near to a straight line as possible.
3. Slowly adjust power take-off up to maintain the voltage indicator in the green portion of the color band.
4. Plug 4 wire load cord set into receptacle. Place transfer switch in the emergency position.
5. Place the load circuit breaker in the "on" position. If the breaker trips, move manual transfer switch to "off" or normal position. Check for short circuit or grounded connection in the load cable to the double throw switch and repair. A breaker that trips from overload or short circuit must be reset by moving to "off" before reclosing.
6. Keep meter in the green by adjusting tractor speed.
7. The return of normal power will be indicated by the lamp on the front of transfer switch; (applicable only when the transfer switch is equipped with indicating lamps or your electrician has installed them). After sufficient time to assure that power restoration isn't temporary, return the transfer switch to normal power (10 - 20 minutes).
8. Place the alternator circuit breaker in "off" position. Do not remove plug before opening the breaker.
9. Slowly reduce power take-off speed to a minimum and disengage the power take-off. Some tractors have a brake on the power take-off that stops the shaft instantly. Stopping the alternator rotor instantly from rated speed may result in a broken shaft or other drive line failures.
10. Exercise PTO alternator for one hour under load at least twice a year.

DANGER: Personal Injury

TRACTOR MUST BE SHUT OFF AND THE POWER TAKE-OFF MUST BE DISENGAGED AT THIS TIME.

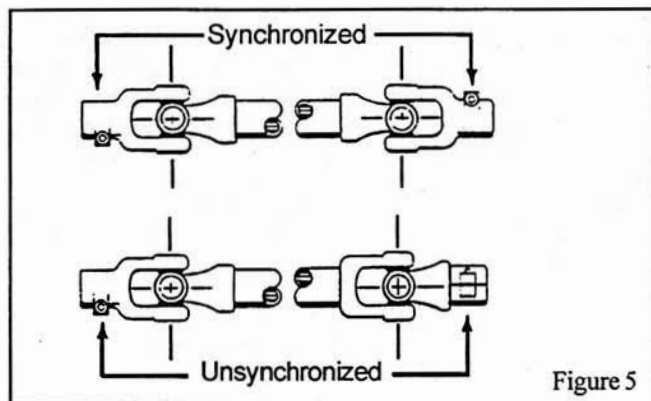

Figure 5

PTO ALIGNMENT

Position the alternator in such a manner that the power take-off shaft is as near to direct line in all directions as possible. This will increase the life of the power take-off shaft, reduce light flicker, reduce wear on bearings of both the power take-off and the alternator, and reduce vibration. The maximum angle from a straight line should not exceed 10°. For a power take-off shaft length of 42 inches, 10° is approximately 7 inch misalignment. For extended distance the maximum misalignment would increase 2 inches for each foot. For example: For a 4 foot PTO shaft, the maximum misalignment is 8 inches from a straight line.

LUBRICATION

1. Check the generator gear case oil level before each use of the generator. See Figure 4. Maintain the oil level before each use of the generator. Maintain the oil level at oil level plug height. The generator is shipped with lubricant in the gear case.

Specifications for gear case lubricant are: API Service: GL-5 EP Rated, Grade: SAE 85W-90-140, Amount: 1 pint
The following kinds of oil are recommended for use in the generator gear case:

Mobil SAE 85W90-140 API Service GL-5

Sunoco/DX XL80W90-140

Kendal Three Star 85W-140

Amoco 85W140 or equivalent

2. The generator bearings are factory lubricated and sealed, and require no further lubrication.
3. The splined generator input shaft should be cleaned and lubricated with a thin film of grease before and after each use of the generator. See Figure 6 for lubrication schedule.
4. The drive shaft (tumbling bar) requires greasing. Keep the universal joints in the coupling shaft free from grease and dirt buildup. See Figure 6 for lubrication schedule.

NOTE: Do not over lubricate the universal joints.

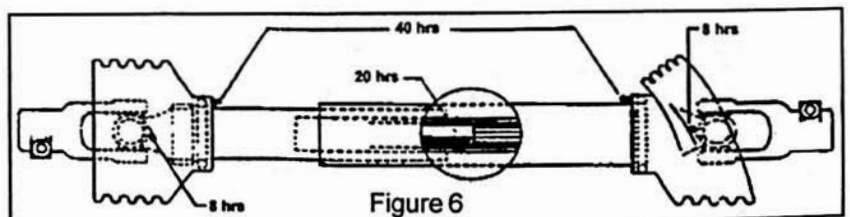

Figure 6

NOTE: THE FOLLOWING INFORMATION IS FOR REFERENCE ONLY - CONSULT A QUALIFIED SERVICE PERSONNEL FOR FURTHER TESTING AND REPAIR.

Testing of Rectifiers

Unbolt the rectifier diode stud from the mounting clamp. Move rectifier away from the metal stud.

1. Connect black lead of meter to stud of rectifier and red lead to the solder terminal. Meter should read a low resistance.
2. Now, reverse the lead on rectifier terminals. Meter should read open circuit of infinite resistance.

A shorted diode will give low resistance reading in both directions.

An open diode will give a high resistance (infinite) reading in both directions.

Handling Procedures for Rectifier Diodes

1. Rectifier diodes should be handled in a manner which avoids the possibility of sudden shocks being applied, such as those encountered in dropping from a work bench to a hard floor. Damage done to the rectifier by such shocks may not be detected by subsequent testing, yet may cause poor system reliability.

2. Any lead trimming or forming operations should be done with care to avoid damaging the leads or the glass header seals.

3. Leads should never be bent or twisted. If lead forming is necessary the lead should be supported so that no bending occurs closer than 1/8 inch to the rectifier body, and that header seals are not fractured or broken. If this seal is broken, it removes mechanical support for the lead and allows entry of moisture into the rectifier, almost assuring early failure.

4. Care must be taken during all soldering operations. It is unsafe to exceed the general specification to which diodes are tested for solder ability. This is 10 +/- 2 seconds at a temperature of 230°C + 5°C at a point 1/16 +/- 1/32 inch from the diode body. This is not as restrictive as it may sound, since 230°C is 446°F and 60/40 solder melts at 375°F, and with proper procedure and soldering tools a solder joint can be made in 4 to 7 seconds. Also, solder joints are almost never made this close to the diode body. Heat sinks, such as a pair of needle nose pliers or alligator clips, can be attached to the lead between the solder joint and the diode body to further reduce the possibility of heat damage.

Also, precautions should be taken to prevent solder or flux bridging which causes a conductive path across the case of the rectifiers. As a precaution all flux should be removed by using alcohol and a small brush. Pay particular attention to assure that glass header seals are free of all flux.

Testing Stator

1. Instrument required - Volt-Ohmmeter. Set on Ohm X1 scale.
2. Check Ohmmeter by touching leads together. Reading should be zero.
3. Tag and lift control wires from stator winding(s) to be checked.
4. **First**, check if stator winding(s) are grounded (most probable).
 - a. Connect one lead of Ohmmeter to ground.
 - b. Touch other lead to each stator wire. Meter should stay at infinite (not move).
 - c. If reading is indicated, stator is grounded and should be replaced.
 - d. Check all three windings.
5. **Second**, check if stator windings for opens. Symptom: when generator was running, no voltage on one line to neutral.

Stator - 6 Wires - 3 Windings 1 Phase

This armature has two power windings and one excitation (auxiliary) winding.

Power (A)	T1-T2	Starting on T1-red Ending on T2-green
Power (B)	T3-T4	Starting on T3-black Ending on T4-yellow
Auxiliary(C)	Z1-Z2	Starting on Z1-white Ending on Z2-brown

1. Connect ohmmeter one lead to T1-red. Other lead to T2-green. Meter should read near zero. Then other lead to T3-black. Meter should read infinite. Then other lead to Z1-white. Meter should read infinite.
2. Connect one lead to T3-black. Other lead to T4-yellow. Meter should read near zero. Then other lead to Z1-white. Meter should read infinite.
3. Connect one lead to Z1-white. Other lead to Z2-brown. Meter should read near zero.

TRACTOR DRIVE WINDING RESISTANCES						
ROTATING FIELD TRACTOR DRIVE						
MODEL	ROTOR		STATOR			450 VAC CAPACITOR
	MAIN	AUX.	POWER T1-T2	POWER T3-T4	AUX. Z1-Z2	
10/7PTCD	2.9	0.77	0.27	0.27	0.79	70 MFD
14/11PTCD	0.37	0.5	0.4	0.4	0.9	80 MFD
18/15PTCD	0.4	0.6	0.3	0.3	0.6	120 MFD

SERVICE DIAGNOSIS

POSSIBLE CAUSE

REMEDY

LOW OUTPUT VOLTAGE

Low Speed

1. Undersized/overloaded.
2. Defective governor.
3. Low power - worn engine.

1. Check for overload on the tractor or undersized.
2. Check tractor governor. Tight or defective throttle levers and joints.
3. Worn or defective tractor engine (see engine manufacturers check list.)

High line loss. Indicated by lower voltage at load than at generator terminals.

Increase size of line wiring. Might also be the result of loose connection indicated by excessive heating at the loose connection terminal.

Defective capacitor.

Test and replace if out of tolerance.

Shorted or grounded rotor coil.

Test and replace if defective.

HIGH OUTPUT VOLTAGE

Excessive Speed

Check tractor engine speed. Governor linkage must be free from dirt and gum.

EXCESSIVE HEATING

Clogged ventilating inlet and/or outlet.

Clean screens, make sure interior of generator is unobstructed.

NO OUTPUT VOLTAGE

Broken or corroded connection.

Clean and tighten generator and receptacle connections.

Defective diode(s) on rotor.

Replace defective diode(s).

Open field circuit.

Repair or replace rotor assembly.

Grounded or shorted field winding.

Replace grounded rotor assembly.

Loss of residual magnetism. Usually occurs only after disassembly of field frame or severe mechanical stress/abuse.

Take to dealer to reflash.

NO OUTPUT VOLTAGE Continued

Shorted stator winding. This can be identified by the use of an internal "growler" at a competent rewinding shop.

Replace stator. (Include generator model and serial number on the order.)

Grounded stator. Check winding by test lamp or high potential tester from stator leads to lamination.

Same as above.

Open stator circuit. Measure circuit between leads with an ohmmeter. Should have a circuit between any pair of rings.

Same as above.

VOLTAGE UNSTEADY/ LIGHTS FLICKERING

PTO drive line alignment.

Realign within 10 degrees.

Drive line knuckles out of sync. (See Figure 5.)

Resync drive line halves.

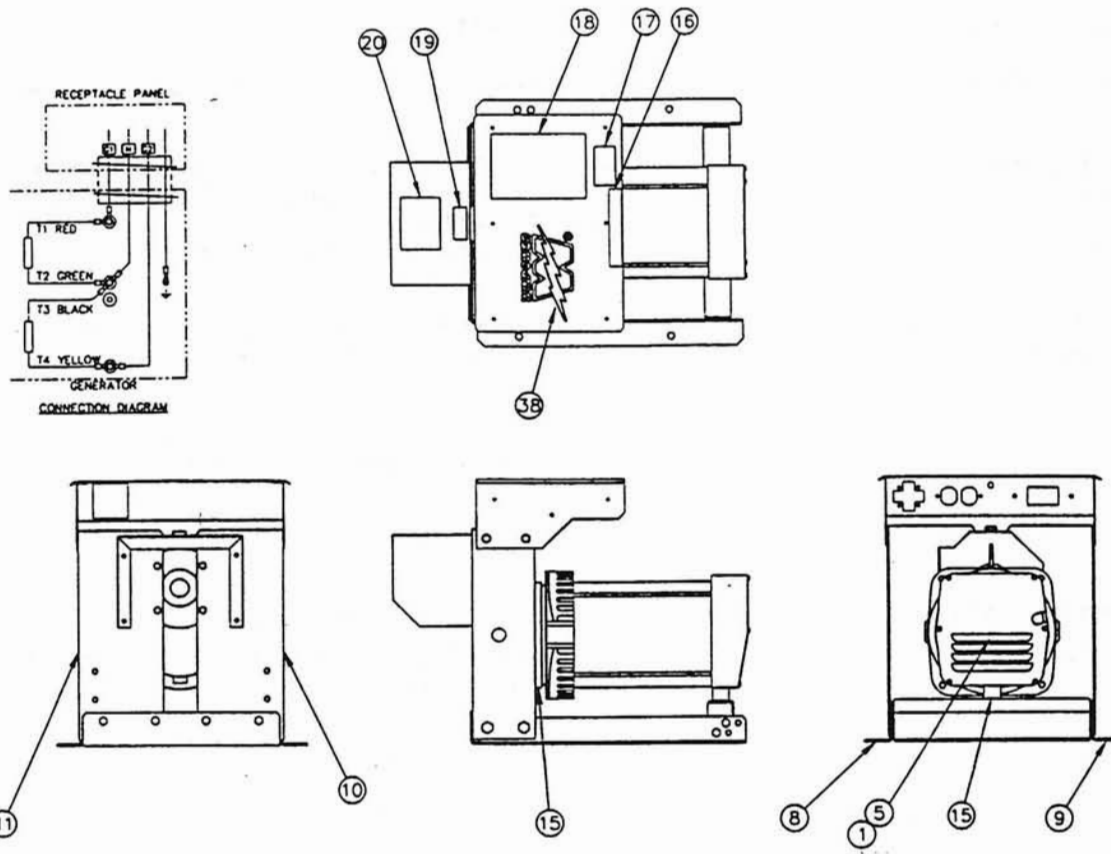

10/7PTCD COMPLETE UNIT ASSEMBLY

DESCRIPTION	PART NO.
1 GENERATOR	300043-9
2 GEARCASE, PTO	300153
3 ADAPTER, SHAFT	300072-1
4 ADAPTER, GEARCASE	300071
5 SPECIAL STUD	23197-35
6 ADAPTER, M14x1.5	300162
7 PANEL, RECEPTACLE	300160-1
8 SIDE, LEFT FRAME	300074-1
9 SIDE, RIGHT FRAME	300074-2
10 SUPPORT, LEFT GEAR CASE	300075-1
11 SUPPORT, RIGHT GEAR CASE	300075-2
12 FRONT, FRAME"	300076
13 REAR, FRAME	300077-1
14 GUARD, DRIVE SHAFT"	300086
15 SPACER, GEN-SUPPORT	300040
16 DECAL SET	15209-3
17 DECAL, WARNING	Z-2516
18 DECAL, OPER. INSTR.	Z-2553
19 DECAL, OIL FILL HOLE"	Z-9941
20 DECAL, DANGER PTO	Z-2568
21 DECAL, WINPOWER	Z-2508-1
22 PLUG, ANGLE 60A 3P 4W	300137

Capacitor - (1) 2400050288

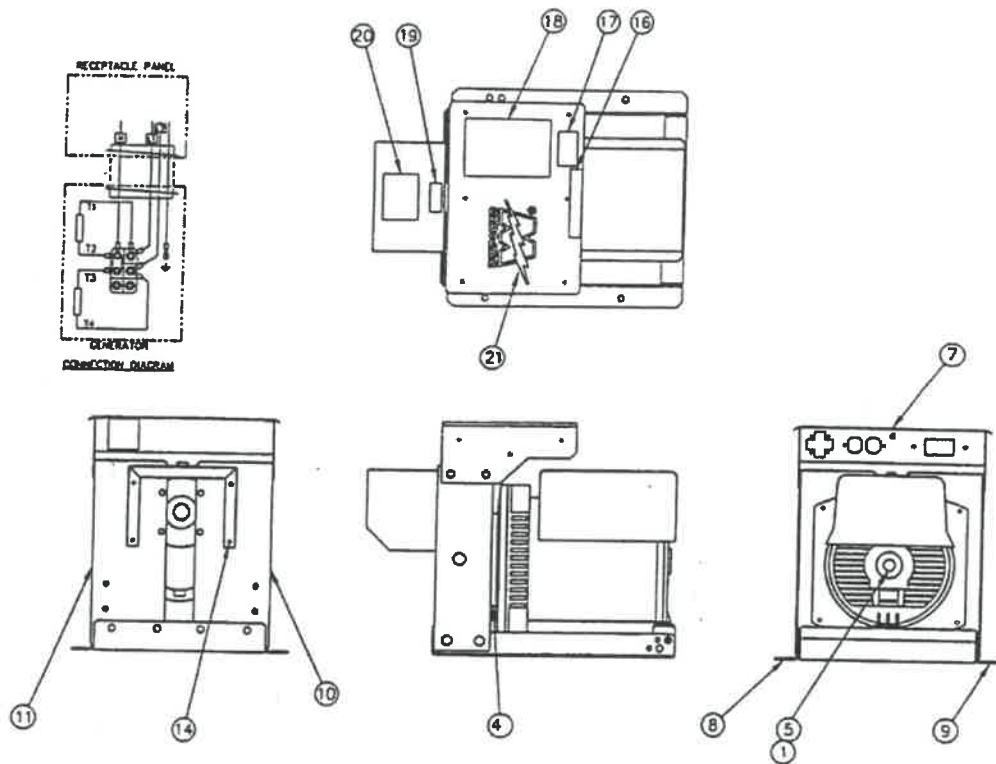

COMPLETE UNIT ASSEMBLY 14/11PTCD 18/15PTCD

DESCRIPTION	PART NO.	PART NO.
1 GENERATOR	300043-10	300043-11
2 GEARCASE, PTO	300153	300153
3 ADAPTER, SHAFT	300072-1	300072-1
4 ADAPTER, GEARCASE	300071	300071
5 SPECIAL STUD	23197-16	23197-16
6 ADAPTER, M14x1.5	300162	300162
7 PANEL, RECEPTACLE	300160-2	300160-3
8 SIDE, LEFT FRAME	300074-1	300074-1
9 SIDE, RIGHT FRAME	300074-2	300074-2
10 SUPPORT, LEFT GEAR CASE	300075-1	300075-1
11 SUPPORT, RIGHT GEAR CASE	300075-2	300075-2
12 FRONT, FRAME"	300076	300076
13 REAR, FRAME	300077-2	300077-2
14 GUARD, DRIVE SHAFT"	300086	300086
15 SPACER, GEN-SUPPORT	N/A	N/A
16 DECAL SET	15209-3	15209-3
17 DECAL, WARNING	Z-2516	Z-2516
18 DECAL, OPER. INSTR.	Z-2553	Z-2553
19 DECAL, OIL FILL HOLE"	Z-9941	Z-9941
20 DECAL, DANGER PTO	Z-2568	Z-2568
21 DECAL, WINPOWER	Z-2508-1	Z-2508-1
22 PLUG, ANGLE 60A 3P 4W	300137	300137

Capacitors

(2) 15051-000

(2) 240005060

40uf capacitors
wired in
parallel.

60uf capacitors
wired in
parallel.

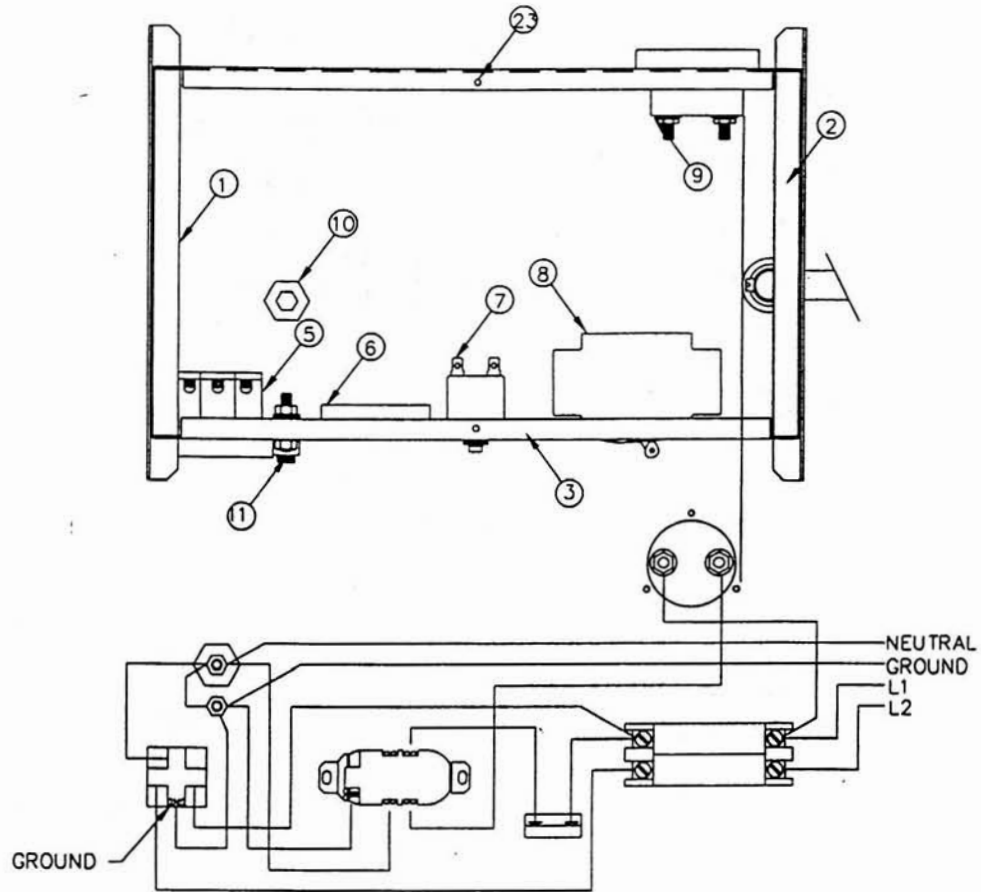

RECEPTACLE PANEL ASSEMBLY

DESCRIPTION	10/7PTCD 300160-1 PART NO.	14/11PTCD 300160-2 PART NO.	18/15PTCD 300160-3 PART NO.
1 SUPPORT, LEFT CONTROL	300078-1	300078-1	300078-1
2 SUPPORT, RIGHT CONTROL	300078-2	300078-2	300078-2
3 BOTTOM, CONTROL	300079-1	300079-1	300079-1
4 COVER, CONTROL (NOT SHOWN)	300080	300080	300080
5 RECEPTACLE, 60 AMP, 4 WIRE	300136	300136	300136
6 RECEPTACLE DUPLEX	240007200	240007200	240007200
7 CIRCUIT BREAKER, 1P/15A	240013150	240013150	240013150
8 CIRCUIT BREAKER, 2P/240V	EE2809-5S(30A)	EE2809-15S(45A)	EE2809-10S(60A)
9 VOLTMETER	VM715	VM715	VM715
10 STANDOFF	94378	94378	94378
11 GROUND LUG	63708	63708	63708

ELECTRICAL CONNECTIONS

CAUTION:

Only qualified electricians should install electrical wiring. Wiring must conform to all applicable national, state, and local codes. (Reference: National Fire Protection Association Manual No. 70, National Electrical Code.)

DANGER: PERSONAL INJURY

IF THE GENERATOR IS TO BE USED AS A STANDBY POWER SOURCE, A SPECIAL DISCONNECT SWITCH MUST BE INSTALLED TO SEPARATE THE GENERATOR AND THE COMMERCIAL POWER LINES. THE DISCONNECT MUST ISOLATE THE GENERATOR FROM THE COMMERCIAL POWER LINES AND THE LOAD WHEN THE GENERATOR IS ON STANDBY, AND MUST ISOLATE THE COMMERCIAL POWER LINES FROM THE LOAD AND THE GENERATOR WHEN THE GENERATOR IS SUPPLYING POWER. SEE FIGURE 6

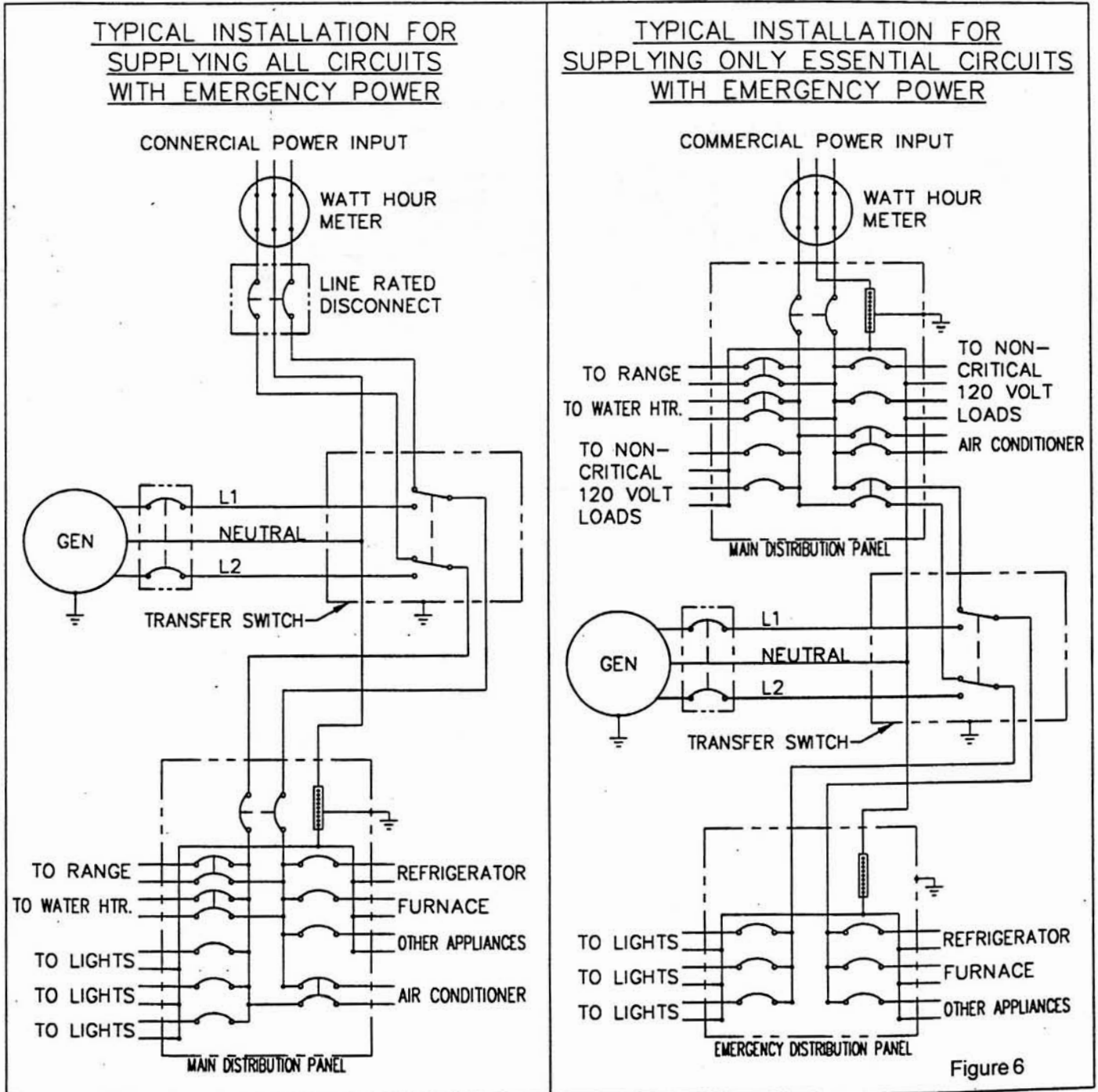
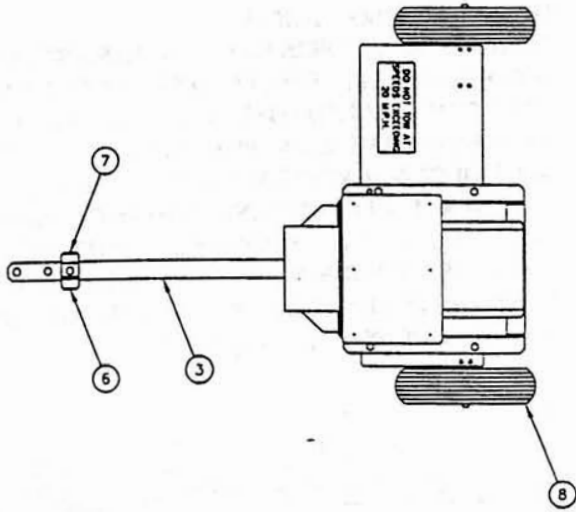
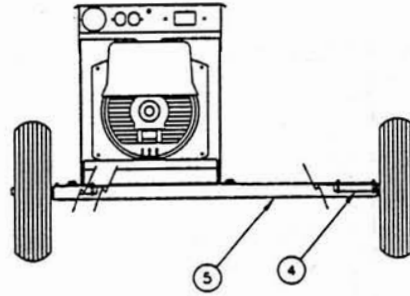
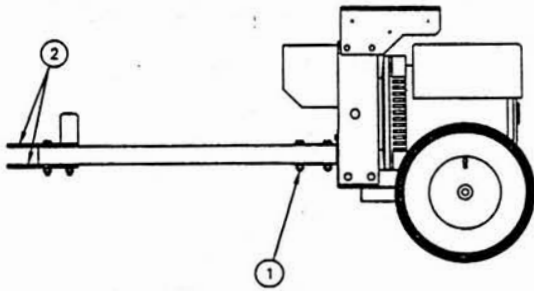

Figure 6



TDM75 TWO WHEEL TRANSPORT

	DESCRIPTION	PART NO.
1	SUPPORT, TONGUE(QTY.2)	300081
2	HITCH, TONGUE(QTY.2)	300082
3	TONGUE	300083
4	AXLE(QTY.2)	300085
5	SUPPORT, AXLE	300164
6	SUPPORT, PTO SHAFT	300161-1
7	SUPPORT, PTO SHAFT	300161-2
8	TIRE/RIM, PNEUMATIC(QTY.2)	43657



WINPOWER

ONE YEAR P.T.O. DRIVEN ALTERNATOR LIMITED WARRANTY

Winpower Inc. hereinafter referred to as Winpower, warrants for a period of one year to the original user that each Winpower PTO driven alternator is free from defects in material and factory workmanship if properly installed, serviced and operated under normal conditions according to Winpower's published instructions.

Manufacturer's obligation under this warranty is limited to correcting without any labor or material charge to the user for the first year at its factory, or at its authorized repair centers, any part or parts which shall be returned and which upon examination shall disclose to Winpower's satisfaction to have been originally defective in material or in workmanship.

All transportation charges on parts or units submitted for replacement or repair to the factory or authorized repair centers under this warranty must be borne by the purchaser.

This warranty does not apply to items which are subject to normal wear or any part or parts which have been subject to misuse, negligence, accident or which have been repaired or altered by other than persons authorized by Winpower.

Winpower shall not be liable for loss, damage or expense directly or indirectly from the use of its product nor for the fitness of product for any specific application or particular purpose.

Winpower shall not be liable for any incidental and consequential damage.

There is no other express warranty. Winpower hereby disclaims any and all implied warranties, including but not limited to those of merchantability and fitness for a particular purpose to the extent permitted by law.

This warranty is effective for all compact PTO driven alternators manufactured after August 15, 1998.

If this alternator is used for standby service, this warranty is void unless a multi-pole, double throw switch is installed between the alternator and the service entrance switch. Do not operate PTO alternator without the shield installed.

**WINPOWER INC.
P.O. BOX 495, ST. PETER, MN 56082
PHONE: 507-357-6700 FAX: 507-357-6580**