

**WINCO INC**<sup>®</sup>  
A Division of **DTE** Dyna Technology Inc

**COMPACT PTO  
GENERATORS**

## OPERATOR INSTRUCTION MANUAL

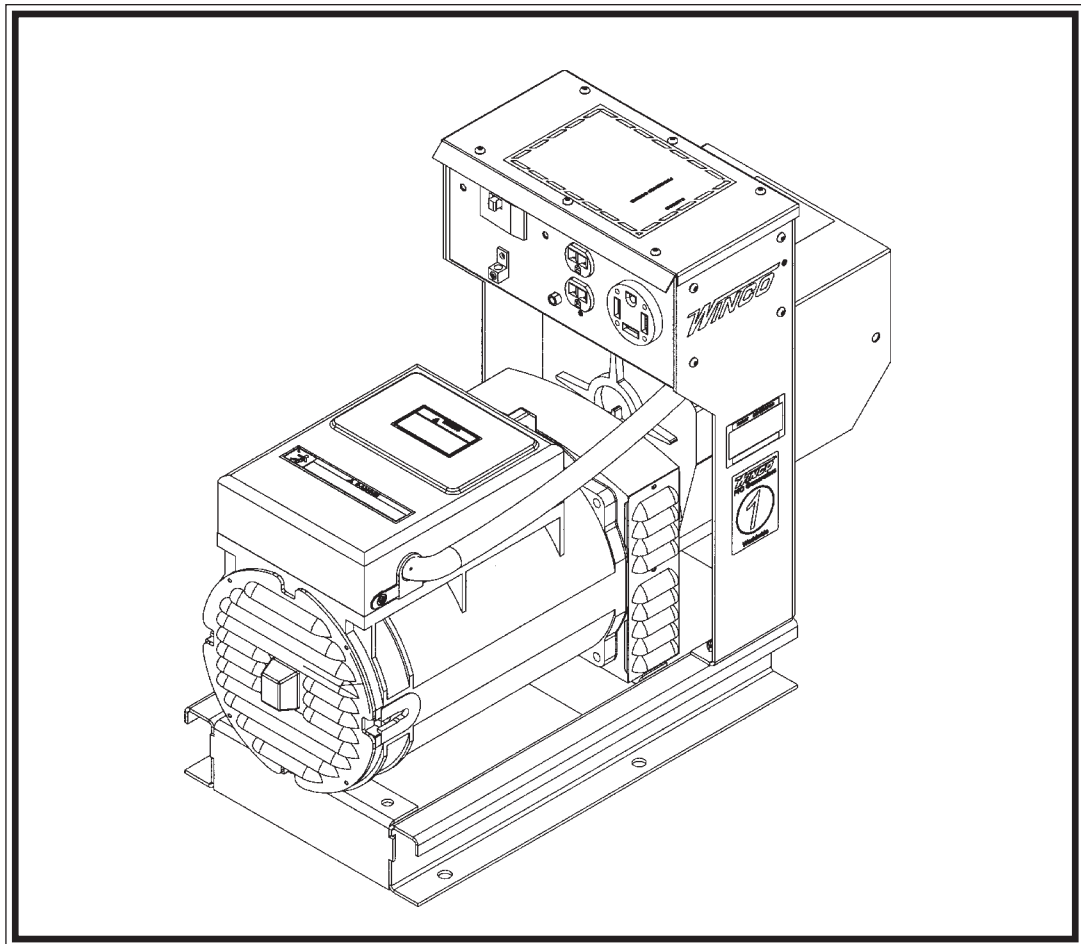

### COMPACT SERIES TRACTOR DRIVE GENERATOR W15PTOS/E

**WINCO INC**<sup>®</sup>  
A Division of **DTE** Dyna Technology Inc

TABLE OF CONTENTS

SAFETY INFORMATION ..... 1  
SPECIFICATIONS ..... 2  
UNPACKING ..... 2  
INSTALLATION ..... 2  
    FOUNDATION MOUNTING ..... 3  
    TRAILER MOUNTING ..... 3  
    THREE POINT HITCH MOUNTIN ..... 3  
ELECTRICAL CONNECTIONS ..... 4  
LOAD DISCONNECT PLUG INSTALLATION ..... 5  
PRE-START CHECKLIST ..... 5  
GENERATOR STARTING PROCEDURE ..... 6  
STORAGE & MAINTENANCE REQUIREMENTS ..... 7  
PTO ALIGNMENT ..... 7  
LUBRICATION ..... 7  
SERVICE DIAGNOSIS ..... 8  
RECEPTACLE PANEL ASSEMBLY ILLUSTRATION/WIRING DIAGRAM ..... 9  
COMPLETE UNIT ASSEMBLY ILLUSTRATION ..... 10  
TWO WHEEL TRANSPORT ..... 11  
WINCO LIMITED WARRANTY ..... 14

Copy you model and serial number here.  
No other Winco generator has the same serial number as yours. It is important that you record the number and other vital information here. If you should ever need to contact us about this unit it will help us to respond to your needs faster.

MODEL \_\_\_\_\_  
SERIAL NUMBER \_\_\_\_\_  
PURCHASE DATE \_\_\_\_\_  
DEALER \_\_\_\_\_

**CAUTION**

FOLLOW THE INSTRUCTIONS IN THE OWNER'S MANUAL SPECIFICALLY WHEN PUTTING THIS PTO GENERATOR INTO SERVICE.

**IMPORTANT**

ALL STANDBY POWER PLANTS INCLUDING TRACTOR DRIVEN GENERATORS SHOULD BE PERIODICALLY EXERCISED. FOR PROPER MAINTENANCE OF YOUR TRACTOR DRIVEN GENERATOR, IT SHOULD BE OPERATED FOR ONE HOUR CARRYING RATED LOAD AT LEAST TWICE A YEAR. THIS WILL ASSURE THAT YOUR PTO GENERATOR IS IN OPERATING CONDITION AND READY FOR USE WHEN THE NEED ARISES.

PARTS LIST, PARTS DRAWINGS, AND WIRING DIAGRAM PERTAINING TO YOUR UNIT ARE ENCLOSED WITH THIS MANUAL.

This manual covers the latest compact portable tractor driven Power Take Off (PTO) generator model from Winco. This 15,000 watt generator is designed to provide 120/240V single phase electrical power for standby and utility service when commercial power is interrupted, inaccessible or impractical. This PTO unit has a cast iron gear case with a 1-3/8" – 6 spline, 540 rpm rated input shaft and brushless, heavy-duty 3600 rpm, 2 pole, low waveform distortion generators.

This compact PTO generator unit is designed to provide reliable electrical power for customers who already have a compact utility tractor with 24 to 40 horsepower and a 540 rpm rated PTO shaft. The PTO unit is a cost-effective way of providing needed electrical power without the cost or added maintenance of a dedicated drive engine. Primary applications for these PTOs are for infrequent or medium duty loads where the unit will normally be operated less than 50 to 100 hours per year. Typical uses might be for farm, ranch or home standby or portable field power away from convenient utility or where running an extension cord is impractical. The compact PTO units are built to last, but are not intended for prime power (continuous or sole source) applications.

# SAFETY INFORMATION

This generator set has been designed and manufactured to allow safe, reliable performance. Poor maintenance, improper or careless use can result in potential deadly hazards; from electrical shock, exhaust gas asphyxiation, or fire. Please read all safety instructions carefully before installation or use. Keep these instructions handy for future reference. Take special note and follow all warnings on the unit labels and in the manuals.

## ANSI SAFETY DEFINITIONS

---

### DANGER:

DANGER indicates an imminently hazardous situation which, if not avoided, will result in death or serious injury. This signal word is to be limited to the most extreme situations.

---

### WARNING:

WARNING indicates a potentially hazardous situation which, if not avoided, could result in death or serious injury.

---

### CAUTION:

CAUTION indicates a potentially hazardous situation which, if not avoided, may result in minor or moderate injury. It may also be used to alert against unsafe practices.

---

### NOTE:

CAUTION is also used on the unit labels and in this manual to indicate a situation that could result in serious damage or destruction of the equipment and possible personal injury.

---

1. **ELECTRIC SHOCK-** The output voltage present in this equipment can cause a fatal electric shock. This equipment must be operated by a responsible person.
  - a. Do not allow anyone to operate the generator without proper instruction.
  - b. Guard against electric shock.
  - c. Avoid contact with live terminals or receptacles.
  - d. Use extreme care if operating this unit in rain or snow.
  - e. Use only three-prong grounded plugs and extension cords.
  - f. Be sure the unit is properly grounded to an external ground rod driven into the earth.
  - g. Do not make or break electrical connection under load.
2. **FIRE HAZARD-** Gasoline, diesel and other fuels always present a hazard of possible explosion and/or fire.
  - a. Keep a fire extinguisher nearby and know its proper use. Fire extinguishers rated ABC by NFPA are appropriate.
3. **DEADLY EXHAUST GAS** - Exhaust fumes from any engine contain carbon monoxide, an invisible, odorless and deadly gas that must be mixed with fresh air.
  - a. Operate only in well ventilated areas.
  - b. Never operate indoors.
4. **NOISE HAZARD** - Excessive noise is not only tiring, but continual exposure can lead to loss of hearing.
  - a. Use hearing protection equipment when working around this equipment for long periods of time.
  - b. Keep your neighbors in mind when permanently installing this equipment.
5. **CLEANLINESS-** Keep the generator and surrounding area clean.
  - a. Remove all grease, ice, snow or materials that create slippery conditions around the unit.
  - b. Remove any rags or other material that could create potential fire hazards.
6. **SERVICING EQUIPMENT-** All service, including the installation or replacement of service parts, should be performed only by a qualified technician.
  - a. Use only factory approved repair parts.
  - b. Do not work on this equipment when fatigued.
  - c. Use extreme caution when working on electrical components. High output voltages from this equipment can cause serious injury or death.
  - d. Always avoid hot mufflers, exhaust manifolds, and engine parts. They all can cause severe burns instantly.
7. **INSTALLATION-** Installing a PTO generator is not a "do-it-yourself" project. Consult a qualified, licensed electrician or contractor. The installation must comply with all national, state, and local codes.
  - a. **NEVER** operate the PTO drive generator without having it properly mounted to a concrete base or approved trailer.
  - b. **NEVER** connect the PTO generator to an existing electrical system without installing an isolation transfer switch.
  - c. Always insure the drive shaft is straight and level before operating the generator.
8. **OPERATION** - PTO drive shafts (Tumbling Bars) have many inherent dangers, extreme caution must be exercised when using them.
  - a. **NEVER** allow children around a drive shaft when it is in operation.
  - b. Keep all safety guards and shields in place and securely tightened.
  - c. **NEVER** operate a drive shaft that has been damaged or had the safety shield removed.
  - d. **NEVER** step over a drive shaft while it is running.
  - e. **NEVER** wear a necktie, loose articles of clothing, or anything else that can be caught in moving parts.
  - f. **NEVER** try to stop a turndrive shaft with your hand or your foot.

## DESCRIPTION

The WINCO rotating field power take-off generators are designed primarily for hobby/small farm use as a standby electrical power supply, utilizing the power take-off of a tractor or truck as the prime mover. This PTO drive generator will provide 120/240V single phase, 60Hz electrical service when properly driven.

**NOTE:** The prime mover which drives the generator must be capable of delivering approximately 2 HP per 1000 watts output from the generator. Observe input RPM specifications.

This generator may be mounted in many different fashions. The three most popular are foundation mounted, trailer mount or 3-point hitch mounted, for used as a standby or portable electrical power source. Your application will dictate how you may want to mount it.

This generator includes a color coded voltmeter to warn against high or low voltage, two output power receptacles with individual circuit breakers for your protection. To reduce maintenance problems, the coupling between the generator input shaft and rotor consists of precision helical gearing rather than a chain link drive. The input shaft is a 1 3/8 in. diameter 6 spline shaft.

The factory thoroughly tests each generator before shipment. All are continuous duty rated.

**IMPORTANT: THE MANUFACTURER STRONGLY RECOMMENDS RUNNING THE GENERATOR UNDER LOAD AT LEAST ONCE A MONTH IN ORDER TO EVAPORATE ANY ACCUMULATED MOISTURE CONDENSATION.**

## SPECIFICATIONS

Model Number	W15PTOS/E
Wattage	15000
Amperage	62.5
Input Speed	515 RPM
Generator Speed	3600 RPM
Input Shaft	1 3/8" - 6 spline
Tractor PTO Hp Required	30
Gear Lube	
Volume	16 ounces
Type	85/90W-140

### Features

- \* Brushless, low harmonic design with skewed rotor and damper windings for minimal load noise
- \* Capacitor Excitation
- \* Dual voltage - 120/240 volt output
- \* 4 wire Load connection plug for convenient full load 120/240 volt output cord set
- \* 15 Amp duplex convenience receptacle
- \* Large face Voltmeter for setting proper speed

## UNPACKING

### CAUTION: Equipment Damage

*DO NOT invert generator during unpacking. The Gearcase contains oil which will leak out if inverted during unpacking.*

Unpack the generator as follows:

1. Remove the carton.
2. Examine the unit for damage.
3. Find the small subpack carton packed in the large carton. Be careful not to throw away the subpack carton with the large carton.
4. Open the subpack carton and make sure it contains:
  - a. Generator instruction manual
  - b. Load disconnect plug (disassembled, in bag)
5. Remove the four bolts which hold down the generator feet to the pallet.
6. Lift the generator from the pallet by means of the lifting eye on the top of the generator.
7. Inspect the generator carefully for freight loss or damage. If loss or damage is noted at time of delivery, require that the person making the delivery make note of the loss or damage on the freight bill, or sign the consigner's memo of the loss or damage. Contact the carrier for claim procedures.

When loss or damage is noted after delivery, segregate the damaged material, and contact the carrier for claim procedures.

"Concealed damage" means damage to the contents of a package which is not evident when the package is delivered by the carrier, but which is discovered later. The carrier or carriers are responsible for merchandise lost or damaged in transit. The title to the goods rests with the consignee when the goods are shipped FOB factory, and only the consignee can legally file claims. Two years are allowed in which to file suit after a claim is disallowed in writing by the carrier.

## INSTALLATION

### FOUNDATION MOUNTING

Mount the generator on a foundation if it is to be used as a permanent or standby power source. See "TRAILER MOUNTING" or "THREE POINT HITCH MOUNTING" if generator will be used as a portable power source. When planning a foundation consider the following points:

- A. The foundation location should enable aligning the drive shaft (tumbling bar) in a straight or nearly straight line between the power take-off and the generator input shaft. Misalignment must be less than 10 degrees during generator operation, even though the mechanical design of the tumbling bar would allow greater misalignment.

**Foundation,  
for Permanent  
Installation**

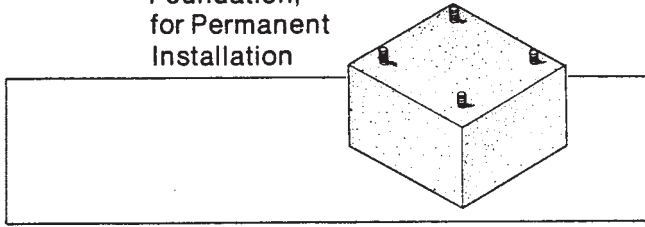

- B. The foundation must be solid enough to absorb generator starting and reflected load torque during operation.
- C. The foundation surface should be flat.
- D. Space is required around the generator for mounting switching devices, making connections, and for servicing.
- E. The generator mounting bracket must rest evenly and firmly on the foundation. Install shims if necessary to even out the foundation under the mounting pads then bolt the generator firmly in place.

**TRAILER MOUNTING**

Mount the generator on a trailer if you plan to use it as a portable power source. When selecting or building a trailer to mount the generator, consider the following points:

- A. The trailer construction must be strong enough to support the generator.
- B. The design of the trailer must enable the trailer to remain stable during operation, and to resist tipping caused by generator starting and reflected load torque.

**WARNING: Personal Injury & Equipment Damage  
TRAILER MAY TIP OVER AND CAUSE INJURIES IF  
WHEELS ARE NOT SPACED FAR ENOUGH APART.**

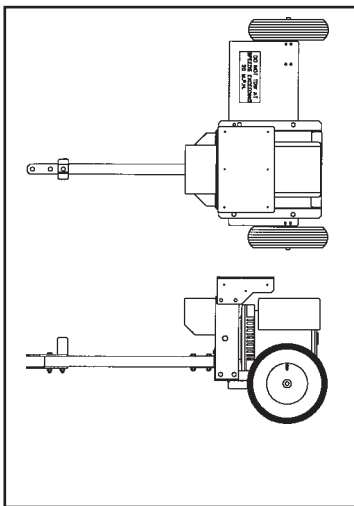

**Optional Trailer Part Number TDM75**

- C. The trailer height and mounting position of the generator on

the trailer should enable aligning the drive shaft (tumbling bar) in a straight or nearly straight line between the power take-off and generator input shafts. Misalignment must be less than 10 degrees during generator operation, even though the mechanical design of the tumbling bar would allow greater misalignment.

- D. The generator mounting area of the trailer bed should be flat.

All four generator mounting pads must rest firmly on the trailer bed. Install shims if necessary to even out the bed under the mounting pads, then bolt the generator firmly in place.

**WINCO THREE POINT HITCH**

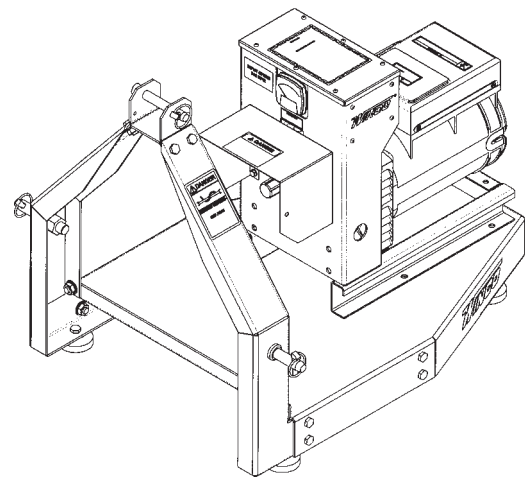

**Optional 3-Point Hitch Part Number TPH240**

**WARNING: Personal Injury & Equipment Damage  
WHEN USING THE 3-POINT HITCH ASSEMBLY ALL THREE  
POINTS MUST BE ATTACHED TO THE TRACTOR. FAIL-  
URE TO DO SO WILL CAUSE THE GENERATOR TO TIP  
WHEN LIFTING IT DAMAGING BOTH THE T-BAR AND THE  
GENERATOR.**

- A. The three point hitch must be attached to the tractor at all times during operation.
- B. When operating the generator the three point hitch and generator must be sitting on flat level ground. All four deck pads must be in constant contact with the ground at all times. This will reduce the vibration in both the generator and the tumbling bar.
- C. For safety the generator must be bolted to the three point hitch deck using all four mounting bolts

# ELECTRICAL CONNECTIONS

**CAUTION:**

Only qualified electricians should install electrical wiring. Wiring must conform to all applicable national, state, and local codes. (Reference: National Fire Protection Association Manual No. 70, National Electrical Code.)

**DANGER: PERSONAL INJURY**

IF THE GENERATOR IS TO BE USED AS A STANDBY POWER SOURCE, A MANUAL TRANSFER SWITCH MUST BE INSTALLED TO SEPARATE THE GENERATOR AND THE COMMERCIAL POWER LINES. THE SWITCH MUST ISOLATE THE GENERATOR FROM THE COMMERCIAL POWER LINES AND THE LOAD WHEN THE GENERATOR IS ON STANDBY, AND MUST ISOLATE THE COMMERCIAL POWER LINES FROM THE LOAD AND THE GENERATOR WHEN THE GENERATOR IS SUPPLYING POWER. SEE FIGURE 6

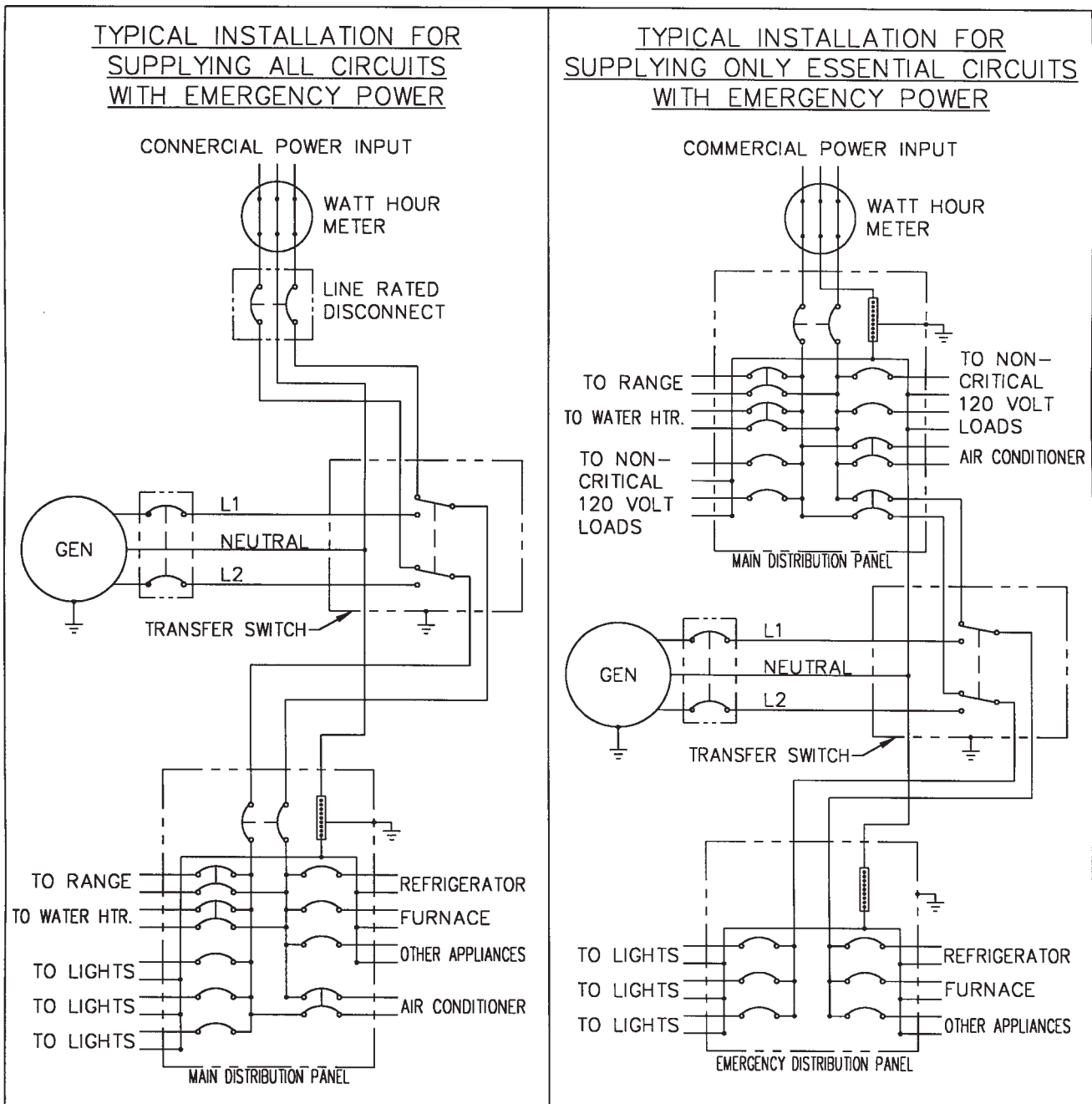

Figure



A properly rated and installed double throw manual power isolation transfer switch must be used with a standby generator. The transfer switch isolates the load from the power line and allows you to safely operate your loads without endangering the power line repair crew. See page 4.

The load, connected to the normal terminals of the transfer switch, is energized by the normal power line when the switch is in the normal position. The generator, connected to the emergency terminals of the switch, furnishes power when the switch is in the emergency mode position.

There are two ways to install a manual transfer switch. The first shown on the left side of page 4 is to install the switch between the watt-hour meter and the normal distribution panel. As with any system you must install an entrance rated breaker before the manual transfer switch. The manual transfer switch must in all cases be equal to or greater than the rating of the entrance rated breaker.

The second way to install the system is to purchase and install an emergency distribution panel and move the circuits you wish to back up to the new distribution panel. In this case the manual transfer switch only has to be sized to the amperage of the circuit breaker in the main distribution panel that is feeding it. See the right hand drawing on page 4

Before deciding which system to install, first determine which loads you can safely run on your PTO generator and the cost of buying a large manual transfer switch versus the cost of a smaller switch and the additional distribution panel.

The final item that you are going to have to assembly/wire is the plug that will be used to connect the generator to the manual transfer switch. You should have found this load plug in a small box when you unpacked the PTO generator. If you need additional plugs for multiple sites you can order additional plugs from your Winco dealer, the part number is "300137".

**WARNING: Personal Injury**  
**DISCONNECT POWER BEFORE WIRING**

**IMPORTANT:** Use copper wire only. Do not use tinned conductors. Sizing cable - see NEC 400-5.

**CORD SIZE:** #4/4 conductor cord SO, 1.25 inch dia. max.

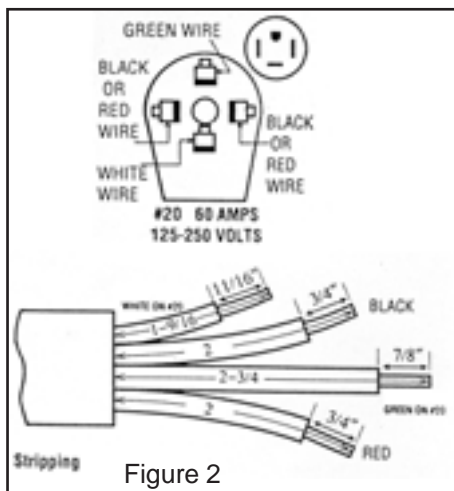

Figure 2

To assemble and wire the load disconnect plug, proceed as follows:

1. Strip outer jacket 2-3/4".
2. Cut and strip leads to lengths specified for the particular plug.
3. Disassemble cable clamp and top cover.
4. Remove one blade at a time, insert the stripped end of the appropriate colored wire designated above, and tighten the set screw.
5. Fit blades through slots in bottom cover and push down until home. Please note: Make sure blades are in correct slots and oriented in accordance with the diagram above or you will not be able to close the top cover fully.
6. Place top plastic cover over assembly and partially tighten the bakelite assembly screw. Realign blades straight (so they fit into the top bakelite housing properly) and tighten the assembly screw.
7. Assemble cable clamp over the outer jacket of the wire and tighten the two clamp screws.

Special Note: For small size round (less than 3/4") and flat cables, the wire clamp may be inverted.

**WARNING: Failure to wire as instructed may cause personal injury or damage to device or equipment. To be installed or checked by an electrician or qualified person only.**

## PRE-START CHECKS

### WARNING: Personal Injury

*When working on or around these generators, do not wear loose fitting clothing or any articles that may get caught in moving parts.*

1. Visually inspect the generator. Check for:
  - a. Correct mounting
  - b. Physical damage
  - c. Debris in cooling vents and screens (could cause generator to overheat).

**IMPORTANT:** The manufacturer recommends that, if the generator has been stored for any length of time, before using it, the operator remove the control box cover and cooling fan screen, then inspect the generator for rodent nests or other objects that could cause generator binding and/or overheating. See "Cleaning" portion of Maintenance section.

2. Check gear case oil level. (See Figure 4.) Case should be filled with oil to plug marked "OIL LEVEL." Fill or remove oil as required.

**NOTE:** EITHER TOO LITTLE OR TOO MUCH OIL CAN HARM THE EQUIPMENT.

See "Lubrication" portion of Maintenance for oil specifications.

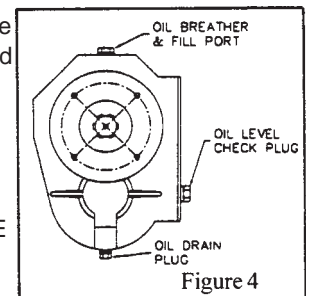
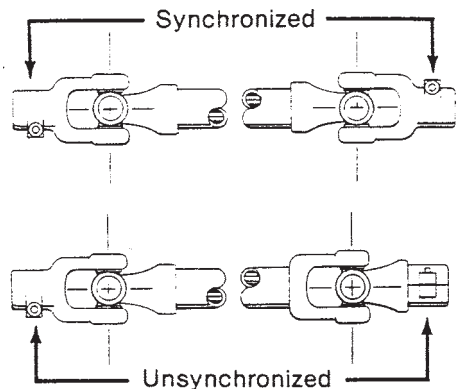

Figure 4

3. Make sure the drive shaft (tumbling bar) is assembled with its universal joint knuckles "synchronized," as illustrated in Figure 7. If knuckles are not synchronized, the bar will chatter when rotating, which will cause the generator output voltage to flicker. Drive shafts shipped new from Winco are always synchronized and tethered so they can not be taken apart.



**DANGER: Personal Injury**  
**POWER TAKE-OFF MUST BE DISENGAGED AT THIS TIME.**

4. Couple the tractor to the generator with the drive shaft (tumbling bar). Couple the tumbling bar to the generator input shaft first, then to the power take-off shaft. Check alignment, tractor, power take-off shaft (tumbling bar), and generator input shaft should form a straight (or nearly straight) line, with less than 10° misalignment between the shafts. Misalignment will cause generator output voltage to flicker.

**CAUTION:**

*Make sure that all tumbling bar lock pins are engaged and that all safety shields are in place before operating the PTO generator.*

5. Make sure no binding exists in generator or gear box. If binding is found, locate the cause and correct it before proceeding.
6. Make sure that the electrical loads to be driven by the generator will not draw more current than the ratings of the generator receptacle or cord set which will supply the current.
7. Check all electrical connections in the system to be energized by the generator. Make sure the connections are correct and are tight.
8. Make sure all loads are turned off. Do not start the generator under load.

## GENERATOR STARTING PROCEDURE

1. Set the manual transfer to mid or normal (up) position.
2. With the power take-off drive disengaged, start the engine which will drive the generator. Run the engine long enough

to warm it up before proceeding, so that it will run smoothly and achieve full power under generator load.

3. With engine idling, engage the power take-off drive.
4. Watch the voltmeter on the generator and slowly increase engine speed until the output reaches approximately 240 to 245 volts, in green portion of voltmeter scale.
5. Plug 4 wire load cord set into receptacle. Place transfer switch in the emergency position.
6. Place the load circuit breaker in the "on" position. If the breaker trips, move manual transfer switch to "off" or normal position. Check for short circuit or grounded connection in the load cable to the double throw switch and repair. A breaker that trips from overload or short circuit must be reset by moving to "off" before reclosing.
7. With engine and generator running smoothly, switch on the electrical load while watching the voltmeter. Readjust engine throttle to keep generator output under load at 240V (in green portion of voltmeter scale). If engine is equipped with speed governor, it may automatically readjust the throttle as the load changes and keep the generator output at the proper level. However, some governors are not sensitive enough to maintain proper output under changing load, and in such cases the throttle will have to be manually readjusted .

**NOTE: Equipment Damage**

***If the load includes motors turn them on one at a time, highest starting current motor first, next highest second, etc.***

8. The return of normal power will be indicated by the lamp on the front of transfer switch; (applicable only when the transfer switch is equipped with indicating lamps or your electrician has installed them). After sufficient time to assure that power restoration isn't temporary, return the transfer switch to normal power (10 - 20 minutes).
9. Place the alternator circuit breaker in "off" position. Do not remove plug before opening the breaker.
10. Slowly reduce power take-off speed to a minimum and disengage the power take-off. Some tractors have a brake on the power take-off that stops the shaft instantly. Stopping the alternator rotor instantly from rated speed may result in a broken shaft or other drive line failures.

**WARNING: Personal Injury**

***Never try to manually stop the generator. Always let it coast until it stops.***

11. Shut off the engine.
12. Disconnect drive shaft (tumbling bar) power take-off end first, then generator end.
13. Exercise PTO alternator for one hour under load at least twice a year.



# STORAGE & MAINTENANCE

If the generator is mounted on an off-highway trailer, such as the Winco trailer, it should be stored in a garage, barn or machine shed in a dry and clean location. The generator should be covered with a tarpaulin to prevent the entrance of dust, chaff, and/or moisture.

The generator may be stored on end, provided the generator is on a clean, dry elevated surface such as a board. Do not have it resting on a dirt surface. (Figure 3)

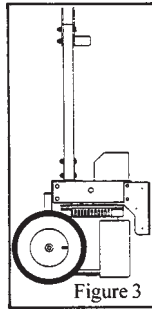

## MAINTENANCE REQUIREMENTS

### LUBRICATION

1. Check the generator gear case oil level before each use of the generator. See Figure 4. Maintain the oil level before each use of the generator. Maintain the oil level at oil level plug height. The generator is shipped with lubricant in the gear case. Specifications for gear case lubricant are: API Service: GL-5 EP Rated, Grade: SAE 85W-90-140, Amount: 1 pint. The following kinds of oil are recommended for use in the generator gear case:

- Mobil SAE 85W90-140 API Service GL-5
- Sunoco/DX XL80W90-140
- Kendal Three Star 85W-140
- Amoco 85W140 or equivalent

### CAUTION: Equipment Damage

**Do not overfill generator gear case. Overfilling causes overheating and oil seal failure.**

2. The generator bearings are factory lubricated and sealed, and require no further lubrication.
3. The splined generator input shaft should be cleaned and lubricated with a thin film of grease before and after each use of the generator. See Figure 6 for lubrication schedule.
4. The drive shaft (tumbling bar) requires greasing. Keep the universal joints in the coupling shaft free from grease and dirt buildup.

**NOTE: Do not over lubricate the universal joints.**

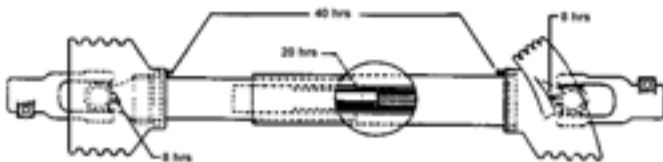

## CLEANING

1. Inspect for loose or broken wiring connections. Make sure that wiring connections are not loose at the generator end, circuit breakers, and receptacles.
2. Do not allow dirt or chaff to collect in the interior of the generator or the ventilation openings. Inspect for indication of the entrance of mice or insects into the generator. The inlet and outlet openings are louvered, but possible damage to the louvers could occur. Mice can destroy the generator winding.

### WARNING: Equipment Damage

**DO NOT CLEAN THE GENERATOR WHILE IT IS RUNNING.**

### CAUTION: Equipment Damage

**Most electrical equipment in North America operates satisfactorily at frequencies between 59 and 61 Hz (cycles per second). Operating the generator at frequencies outside that range may cause damage to the generator and/or to electrical equipment driven by the generator.**

Figure 6

## SERVICE DIAGNOSIS

### POSSIBLE CAUSE

### REMEDY

#### LOW OUTPUT VOLTAGE

Low Speed

1. Undersized/overloaded.
2. Defective governor.
3. Low power - worn engine.

Check for overload on the tractor or undersized.  
Check tractor governor. Tight or defective throttle levers and joints.  
Worn or defective tractor engine (see engine manufacturers check list.)

High line loss. Indicated by lower voltage at load than at generator terminals.

Increase size of line wiring. Might also be the result of loose connection indicated by excessive heating at the loose connection terminal.

Shorted or grounded rotor coil.

Test and replace if defective.

Defective stator

Repair or replace as required

#### HIGH OUTPUT VOLTAGE

Generator is spinning too fast, slow tractor down.

Readjust or Replace as required

#### EXCESSIVE HEATING

Clogged ventilating inlet and/or outlet.

Clean screens, make sure interior of generator is unobstructed.

#### NO OUTPUT VOLTAGE

Broken or corroded connection.

Clean and tighten generator and receptacle connections.

Defective diode(s) on rotor.

Replace defective diode(s).

Open excitor circuit in stator

Repair or replace stator assembly.

Grounded or shorted rotor winding.

Replace grounded rotor assembly.

Loss of residual magnetism. Usually occurs only after disassembly of field frame or severe mechanical stress/abuse.

Back flash the 120 volt circuit with 12 volts DC

Shorted stator winding. This can be identified by the use of an internal "growler" at a competent rewinding shop.

Replace stator. (Include generator model and serial number on the order.)

Grounded stator. Check winding by test lamp or high potential tester from stator leads to lamination.

Same as above.

Open stator circuit. Measure circuit between leads with an ohmmeter. Should have a circuit between any pair of leads.

Same as above.

Defective Capacitors

Test and replace if defective.

#### VOLTAGE UNSTEADY/ LIGHTS FLICKERING

PTO drive line alignment.

Realign within 10 degrees.

Drive line knuckles out of sync. (See Figure 5.)

Resync drive line halves.

# RECEPTACLE PANEL

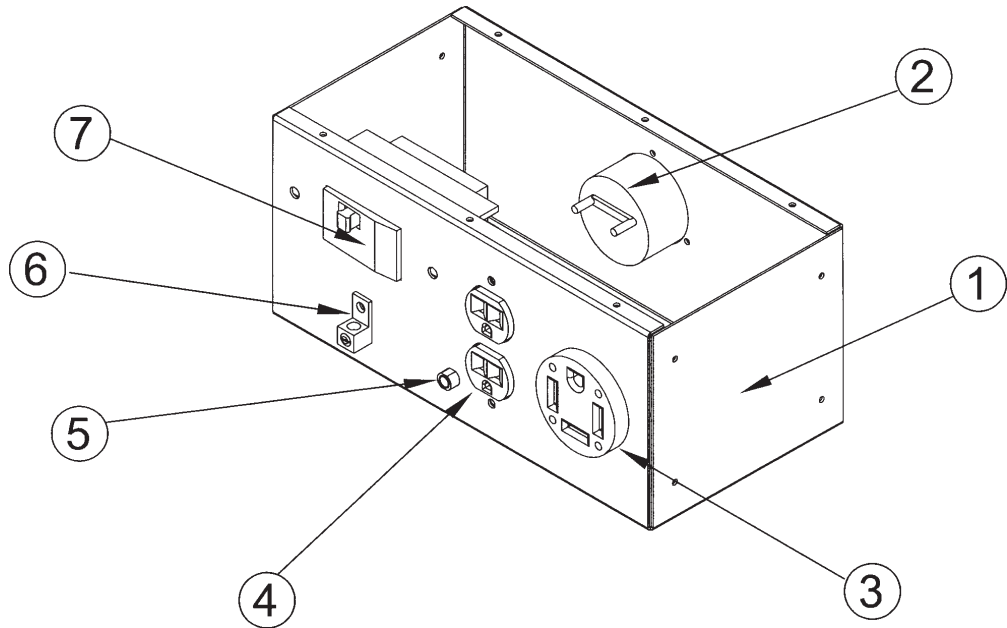

REF	PART #	QTY	DESCRIPTION
1	300079-4	1	Control Box Sheet Metal
2	91370-000	1	Voltmeter 0 - 300 VAC
3	300136	1	Receptacle, NEMA 14-60R
4	50766-000	1	Receptacle, NEMA 5-20R
5	91286-001	1	Circuit Breaker 20 AMP - 120 VAC
6	63708-000	1	Ground Lug
7	57030-005	1	Circuit Breaker 60 AMP - 240 VAC
NI	300137	1	Plug, NEMA 14-60P (Supplied with the Unit)

## WIRING DIAGRAM

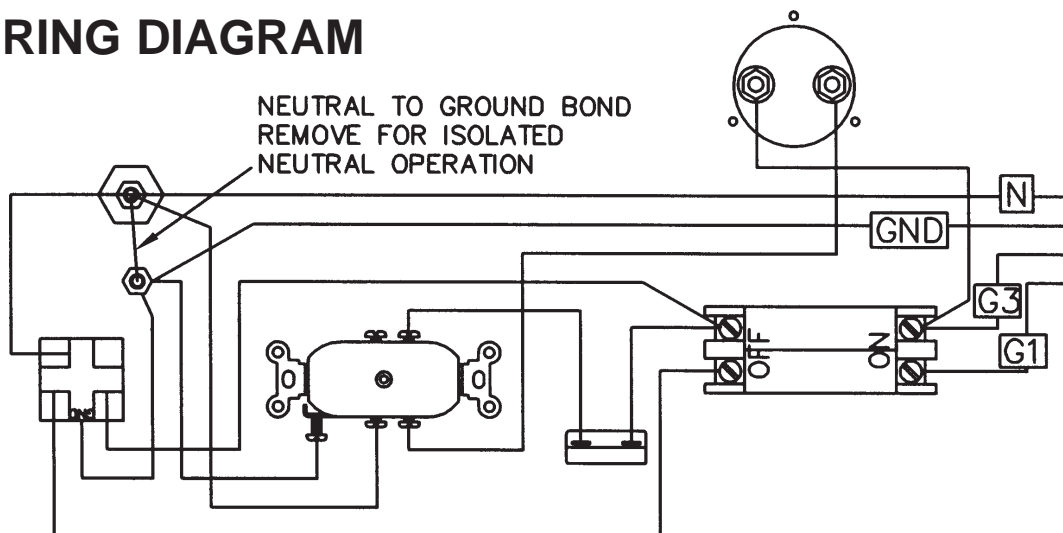

# COMPLETE UNIT ASSEMBLY

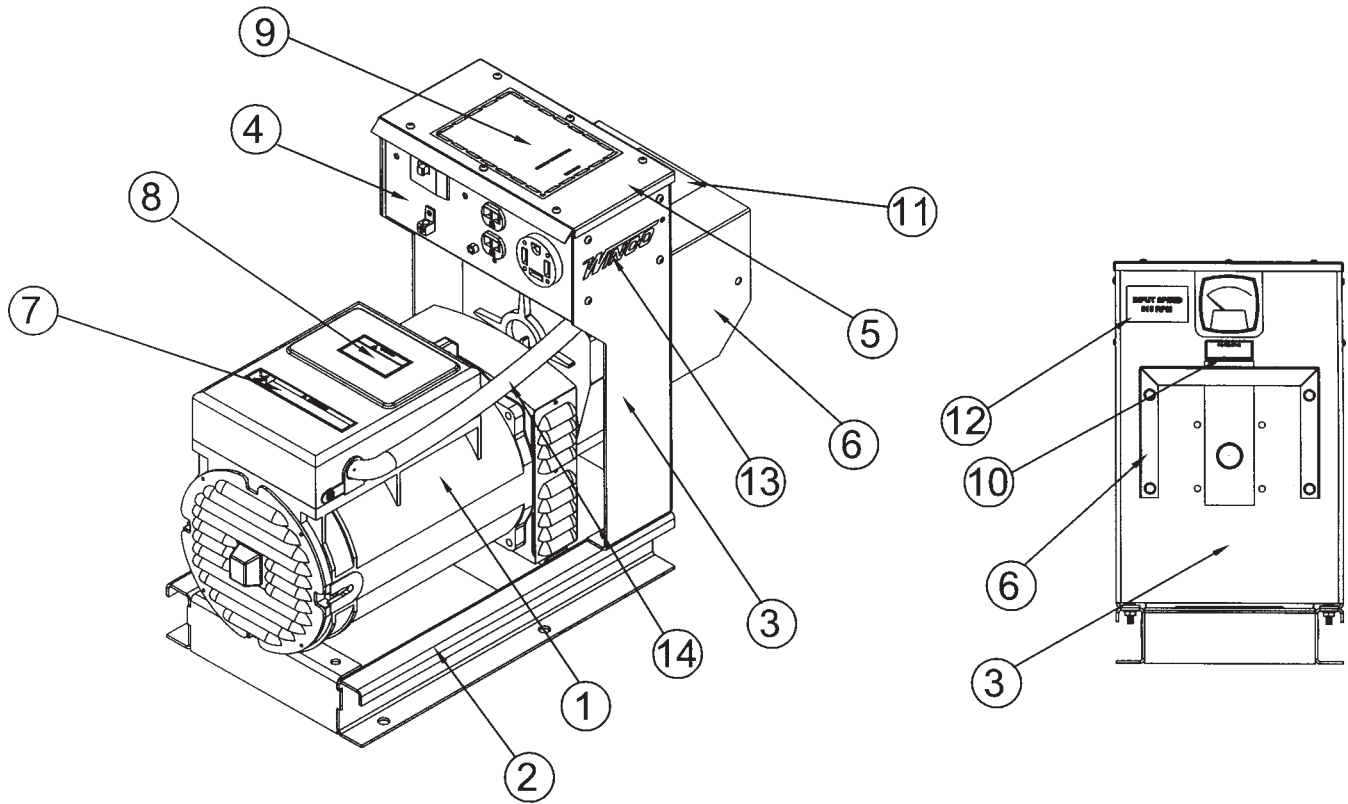

REF	PART #	QTY	DESCRIPTION	REF	PART #	QTY	DESCRIPTION
1	99839-001	1	Generator & Gear Case Assy S20F-230/A M5	10	Z9941	1	Oil Fill Hole Decal
2	300077-6	1	Base Assembly	11	Z2568	1	PTO Danger Decal
3	99841-002	1	Gear Case Support	12	91369-003	1	515 RPM Decal
4	300160-6	1	Receptacle Box Assembly	13	53113-001	1	WINCO Decal
5	300080-2	1	Receptacle Box Cover	14	62487-003	2.5'	Loom 5/8"
6	300086-1	1	Safety Shield	NI	300323-112	1	Capacitor, 31.5 mf, 425 V
7	15209-000	1	Safety Decal	NI	300323-212	2	Capacitor, 35 mf, 450 V
8	Z-2516	1	Warning Decal	NI	300153	1	Gear Case
9	Z2553	1	Operating Instructions Decal	NI			Not Illustrated

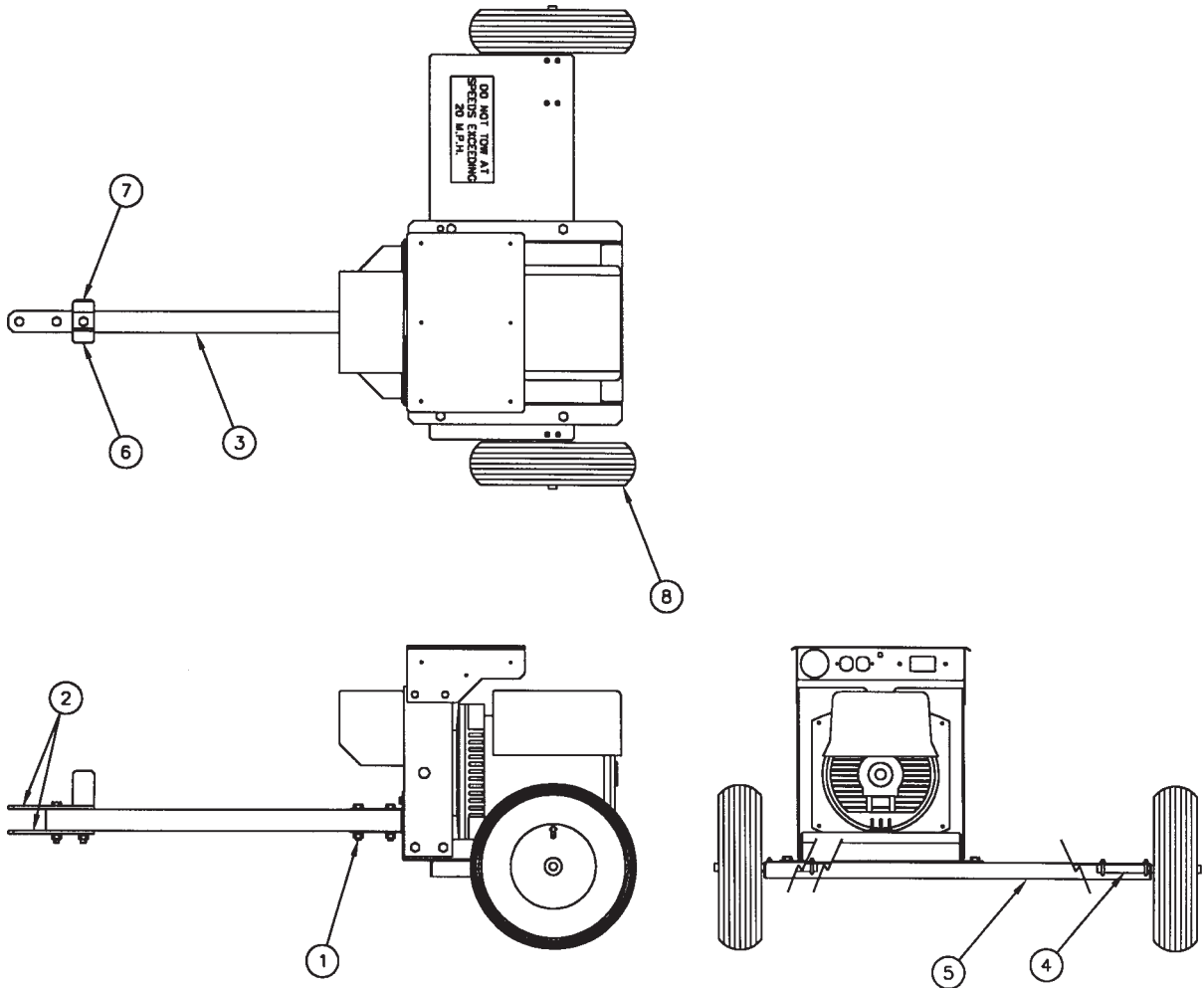

## TWO WHEEL TRANSPORT

DESCRIPTION	PART NO.
1 SUPPORT, TONGUE (QTY. 2)	300081
2 HITCH, TONGUE (QTY. 2)	300082
3 TONGUE	300083
4 AXLE (QTY. 2)	300085
5 SUPPORT, AXLE	300164
6 SUPPORT, PTO SHAFT	300161-1
7 SUPPORT, PTO SHAFT	300161-2
8 TIRE/RIM, PNEUMATIC (QTY. 2)	43657-000





# PTO GENERATOR

## 12 MONTH LIMITED WARRANTY

WINCO, Inc., warrants for twelve months from date of shipment, that it will repair or replace at its option, for the original user, the whole or any part of the product found upon examination, by WINCO at its factory at 225 South Cordova Avenue, Le Center, Minnesota, or by any factory-authorized service station, to be defective in material or workmanship under normal standby use.

For warranty service, return the product within 12 months from the date of purchase, transportation charges prepaid, to your nearest factory-authorized service station or the WINCO factory.

There is no other express warranty. To the extent permitted by law, any and all warranties, including those of merchantability and fitness for a particular purpose, are limited to 12 months from date of shipment, and liability for incidental or consequential damages or expenses is excluded. Some states do not allow limitations on the duration of an implied warranty, and some states do not allow the exclusion or limitation of incidental or consequential damages, so that above limitation or exclusion may not apply to you. This warranty gives you specific legal rights; you may have other rights which vary from state to state.

This warranty is limited to bench labor and parts only, no allowance will be made for travel time, or removal and reinstallation of the PTO unit.

WINCO does not warrant drive lines, trailer tires, receptacles, or certain other component parts of the product installed by others, since such items are warranted by their manufacturers.

WINCO does not warrant modifications or alterations which were not made or authorized by the WINCO factory and which affect the stability or reliability of the product.

WINCO does not warrant products which have been exposed to misuse and/or negligence or have been involved in an accident.

WINCO does not warrant products which have been installed in such a manner as not to protect them from the adverse environmental conditions (water, mud, insects, etc.) or have not been kept clean.

WINCO reserves the right to change or improve its products without incurring any obligations to make such changes or improvements on products purchased previously.



225 SOUTH CORDOVA AVE  
LE CENTER MN 56057  
1-507-357-6831

**WINGO INC**<sup>®</sup>  
*A Division of **DTE** Dyna Technology Inc*