



25PTOC-3/F
CSA8PTOC-3/C

READ ALL INSTRUCTIONS CAREFULLY BEFORE ATTEMPTING TO INSTALL, OPERATE OR SERVICE THE GENERATOR. PROTECT YOURSELF AND OTHERS BY OBSERVING ALL SAFETY INFORMATION. FAILURE TO COMPLY WITH INSTRUCTIONS COULD RESULT IN PERSONAL INJURY AND/OR PROPERTY DAMAGE!

RETAIN INSTRUCTIONS FOR FUTURE REFERENCE.

Description

These rotating armature power take-off generators are designed primarily for farm use as a standby electrical power supply, utilizing the power take-off of a tractor or truck as the prime mover. The portable trailer-mounted unit can be used to provide electrical power to machinery and out-buildings where commercial power is not accessible.

NOTE: The prime mover which drives the generator must be capable of delivering approximately 2.2 H.P. per 1000 watts output from the generator.

Unpacking

NOTE: DO NOT invert generator during unpacking. Gearcase contains oil.

Unpack the generator as follows:

1. Remove strapping from carton.
2. Lift off carton.
3. Remove the small subpack carton.
4. Open the subpack carton; it contains:
 - a. One generator instruction manual
 - b. One load disconnect plug (disassembled, in bag) for 25PTOC-3/F One range/welding plug, for CSA8PTOC-3/C
 - c. One quality control inspection tag.
5. Remove the four bolts which hold down the generator feet to the pallet. (A six inch crescent wrench is suitable for this job.)
6. Lift the generator from the pallet by means of the lifting eye on the top of the generator.
7. Inspect the generator for freight loss or damage.

General Safety Information

1. Do not allow anyone to operate the generator without proper instruction.
2. Guard against electric shock.
3. Avoid touching live terminals or receptacles.
4. Be extremely careful if operating this generator in rain or snow.
5. Do not make or break electrical receptacle connections under load.
6. Use only grounded receptacles and extension cords.

7. This generator must be properly grounded.
8. Hot engine parts, moving parts, and generator output all can seriously injure the generator operator. The operator must use caution and remain alert when using this generator.
9. Provide safety guards for all drive systems.
10. Keep all safety guards and power shields in position and tightly secured.
11. When operating this generator, do not wear neckties, loose articles of clothing, or anything else that can be caught in moving parts.
12. Engine exhaust fumes are poisonous. Do not inhale them. Provide adequate ventilation if prime mover for generator is gas or diesel engine. Be sure generator itself is well ventilated.
13. The generator manufacturer recommends that only qualified electrical technicians be allowed to service (install, maintain, repair, or replace parts) this generator, and that only factory approved repair parts be used in it.
14. Do not work on this generator when fatigued.
15. Use extreme caution when working on electrical components. High generator output can cause injury or death.
16. Installing and wiring a home-standby generator installation is not a "do it yourself" project. Consult a qualified, licensed electrician or contractor. The installation must comply with all national, state, and local codes.
17. Excessive noise is tiring, and continual exposure to it can cause some degree of temporary and permanent hearing loss. Muffle engine noise with the best available noise suppression equipment; wear noise protection devices when necessary.
18. Keep the generator and the area around it clean. Remove all material that can create slippery conditions, such as grease, water, ice, and snow. Also remove oily rags and other flammable material from the area.
19. Keep a fire extinguisher near the generator. Extinguishers rated ABC by the NFPA are appropriate for this use. Consult the local fire department if you have questions regarding fire extinguisher ratings. Keep the extinguisher properly maintained and be familiar with its proper use.

Specifications

MODEL	WATTS	VOLTS	AMPS	HZ.	PH	INPUT RPM	GEN. RPM	INS.
8PTOC	8000	120/240	66/33	60	1	540	3600	B
25PTOC	25000	120/240	208/104	60	1	540	3600	F

Assembly

The only assembly required after unpacking the generator is to assemble and/or wire the plugs packed in the subpack carton, packed in the generator carton. The load disconnect plug provided with 25PTOC-3/F is packed in a bag.

The bag contains an instruction sheet, a plug body, three brass pins (large pin for neutral), and a manila envelope. The envelope contains an allen wrench, three retainer pins, and three set screws.

To assemble and wire the load disconnect plug, proceed as follows (See Figure 1):

1. Cut lead cables to the required length.
2. Strip off insulation 7/8" back from one end of each cut-to-length cable.
3. Start a set screw into each pin.
4. Insert the stripped end of one cable fully into one of the brass pins, and tighten the set screw firmly to secure the cable end in the pin.

CAUTION: If cable-to-pin connection is loose, arcing and heat damage to equipment can result.

5. Insert the brass pin (with cable) into the plug body, and line up the retainer pin holes in the brass pin with those in the plug body.
6. Insert the retainer pin, and tap it firmly into place. The retainer pin will protrude approximately 3/8" when fully seated (See Figure 1).
7. Repeat steps 4 through 6 for each brass pin. Make sure to connect the neutral lead (cable), identified and color coded in conformance with the applicable local electrical codes, to the large diameter pin ("N") on the plug.

WARNING: DURING THE NEXT STEP, THE LOAD DISCONNECT PLUG SHOULD NOT BE PLUGGED INTO ITS RECEPTACLE. ALSO, MAKE SURE THAT THE EQUIPMENT TO WHICH THE PLUG LEADS ARE BEING CONNECTED IS NOT ENERGIZED (LIVE).

8. Strip the insulation off the free end of each of the plug leads and connect them to the load transfer switch (or directly to the load).

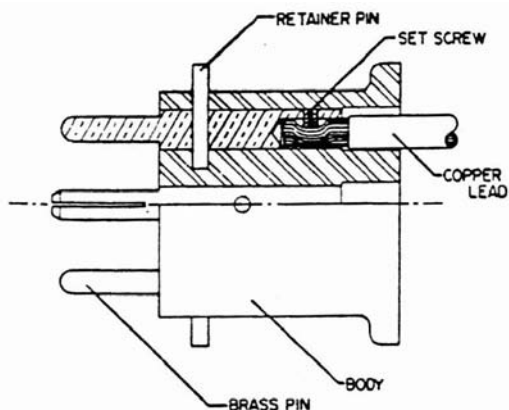

Figure 1

Installation

FOUNDATION MOUNTING

Mount the generator on a foundation if it is to be used as a leave-in standby power source.

When planning a new foundation, consider the following points (See Figure 2):

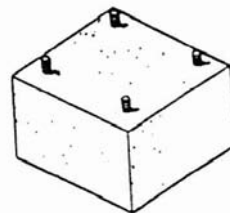

Figure 2 — Foundation for Permanent Installation

1. The foundation location should enable aligning the tumbling bar (coupling shaft) in a straight (or nearly straight) line with the power take-off and the generator input shaft. (Misalignment must be less than 15 degrees even though the mechanical design of the tumbling bar would allow greater misalignment.)
2. The foundation must be solid enough to absorb generator starting and reflected load torque during operation.
3. The foundation surface should be flat.
4. Space is required around the generator for mounting switching devices, making connections, and for servicing.
5. All four generator mounting pads must rest firmly on the foundation. Install shims if necessary to even out the foundation under the mounting pads, then bolt the generator firmly in place.

TRAILER MOUNTING

Mount the generator on a trailer if you plan to use it as a portable power source.

When selecting or building a trailer to mount the generator, consider the following points (See Figure 3):

1. The trailer construction must be strong enough to support the generator.
2. The design of the trailer must enable the trailer to remain stable during operation, and to resist tipping caused by generator starting and reflected load torque.

WARNING: TRAILER MAY TIP OVER AND CAUSE INJURIES IF WHEELS ARE NOT SPACED FAR ENOUGH APART.

3. The trailer height and mounting position of the generator on the trailer should enable aligning the tumbling bar (coupling shaft) in a straight (or nearly straight) line with the power take-off and generator input shafts. (Misalignment must be less than 15 degrees even though the mechanical design of the tumbling bar would allow greater misalignment.)

Installation

- The generator mounting area of the trailer bed should be flat.
- All four generator mounting pads must rest firmly on the trailer bed. Install shims if necessary to even out the bed under the mounting pads, then bolt the generator firmly in place.

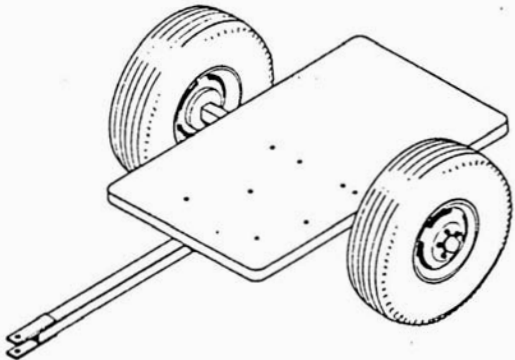

Figure 3 — Trailer for Portable Installation

OUTPUT POWER AND LOAD DETERMINATION

The power take-off generators are supplied with control boxes, receptacles, fuses or circuit breakers. The maximum load which should ever be applied to the generator is the KW (kilowatt) or wattage rating of the generator. This rating is stamped on the generator identification nameplate. Depending on the generator model, this maximum load will only be available at the Load Disconnect plug.

Receptacles provided are restricted to their design voltage and amperage rating. Some models have circuit breaker/fuse protection for the receptacles. Use the following formula to find the load current of different appliances.

Load Wattage Rating = Load current in amperes

120 volts

Example:

Food freezer requires 300 watts

$$\frac{300 \text{ watts}}{120 \text{ volts}} = 2.5 \text{ amps.}$$

120 volts

Refrigerator requires 325 watts

$$\frac{325 \text{ watts}}{120 \text{ volts}} = 2.7 \text{ amps.}$$

120 volts

Ten 100 watt light bulbs require 1000 watts

$$\frac{1000 \text{ watts}}{120 \text{ volts}} = 8.3 \text{ amps.}$$

120 volts

Freezer = 2.5 amps.

Refrigerator = 2.7 amps.

Lights = 8.3 amps.

Total Load = 13.5 amps.

Use the same method to figure the load current for the 240 volt electrical loads.

NOTE: Check appliance/motor nameplate for voltage, current, and wattage specifications when figuring load current.

Operation

USING ELECTRIC MOTORS WITH GENERATOR SETS

When using an electric motor with the generator set, consider the starting current of the motor. All single phase electric motors require more starting current than running current, and starting currents vary greatly between different types of motors. Capacitor-Start motor starting currents are 4 to 4-1/2 times the running current, and Split-Phase motor starting currents are 5 to 5-1/2 times the running current.

NOTE: In applications where several motors are to be started, do not start them at the same time to avoid overloading the generator. Start the motor that requires the highest starting current first.

PRE-START CHECKS

WARNING: WHEN WORKING ON OR AROUND THIS GENERATOR, DO NOT WEAR LOOSE FITTING CLOTHING OR ANY ARTICLES THAT MAY GET CAUGHT IN MOVING PARTS.

- Visually inspect the generator. Check for:
 - correct mounting
 - physical damage
 - debris in cooling vents and screens (could cause generator to overheat).

CAUTION: If the generator has been stored for any length of time it is recommended that the control box cover and the end cover be removed, and the generator inspected for rodent nests or other foreign objects that could cause binding or overheating of the generator. See "Cleaning" generator maintenance for procedures.

- Check gear case oil level. See Figure 4. Case should be filled with oil to plug marked "OIL LEVEL." Fill or remove oil as required.

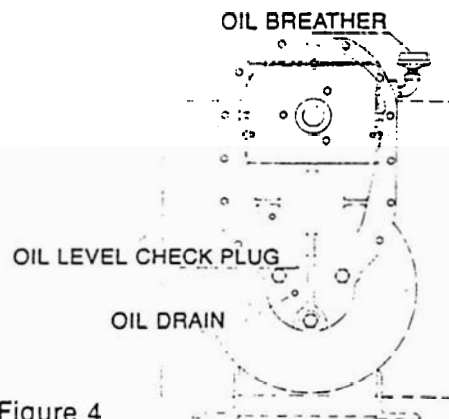

Figure 4

CAUTION: Either too little or too much oil can harm the equipment. See "Lubrication" portion of Maintenance for oil specifications.

- Make sure tumbling bar (coupling shaft) is assembled with its universal joint knuckles "synchronized," as illustrated in Figure 5. If knuckles are not synchronized, the bar will chatter when rotating, which will cause the generator output voltage to fluctuate and can also cause tumbling bar failure or shortened generator life.

Operation (Continued)

WARNING: POWER TAKE-OFF MUST BE DIS-ENGAGED AT THIS TIME.

4. Couple the generator drive (power take-off) to the generator with the tumbling bar. Couple the tumbling bar to the generator input shaft first, then to the power take-off shaft. Check alignment: power take-off shaft, tumbling bar, and generator input shaft should form a straight (or nearly straight) line, with less than 15° misalignment between the shafts. Misalignment will cause generator output voltage to fluctuate or damage the tumbling bar and generator.

WARNING: MAKE SURE THAT ALL TUMBLING BAR LOCK PINS ARE ENGAGED AND THAT ALL SAFETY SHIELDS ARE IN PLACE.

5. Make sure no binding exists in generator or gear box by rotating tumbling bar by hand. If binding is found, locate the cause and correct it before proceeding.
6. Make sure that the electrical loads connected will not draw more current than the rating of the generator or receptacle being used.
7. Check all electrical connections in the system to be energized by the generator. Make sure the connections are correct and are tight.
8. Make sure all loads are turned off.

CAUTION: Do not start the generator under load.

speed governor, it may automatically readjust the throttle as the load changes and keep the generator output at 240V. However, some governors are not sensitive enough to maintain 240V output under changing load, and in such cases the throttle will have to be manually readjusted.

GENERATOR SHUTDOWN

1. Switch off electrical load.
2. Reduce speed of engine driving generator to idle.
3. Disengage power take-off drive, and allow generator to coast to a stop.

WARNING: NEVER TRY TO MANUALLY STOP THE GENERATOR — LET IT COAST UNTIL IT STOPS!

4. Disconnect tumbling bar (coupling shaft) power take-off end first, then generator end.

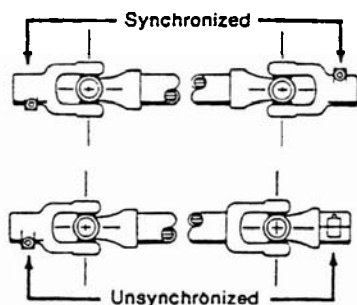

Figure 5

GENERATOR STARTING

1. With the power take-off drive disengaged, start the engine which will drive the generator. Run the engine long enough to warm it up before proceeding, so that it will run smoothly and achieve full power under generator load.
2. With engine idling, engage the power take-off drive.
3. Watch the voltmeter on the generator and slowly increase engine speed until the output reaches approximately 260 volts (in green portion of voltmeter scale).
4. With engine and generator running smoothly, switch on the electrical load while watching the voltmeter. Readjust engine throttle to keep generator output under load at 240V (in green portion of voltmeter scale). If engine is equipped with a

Wiring Diagrams

ELECTRICAL CONNECTIONS

NOTE: Only qualified electricians should install electrical wiring. Wiring must conform to all applicable national, state, and local codes, (Reference: National Fire Protection Association Manual No. 70, National Electrical Code.)

CAUTION: When making standby service hook up, make sure load to be transferred does not exceed generator rating.

WARNING: IF THE GENERATOR IS TO BE USED AS A STANDBY POWER PLANT WIRED INTO THE EXISTING COMMERCIAL SYSTEM, A DISCONNECT SWITCH MUST BE INSTALLED WHICH WILL ISOLATE THE GENERATOR FROM THE COMMERCIAL POWER WHENEVER THE GENERATOR IS NOT OPERATED, AND WILL ISOLATE THE COMMERCIAL POWER FROM THE GENERATOR WHEN THE GENERATOR IS OPERATING (SEE FIGURE 6).

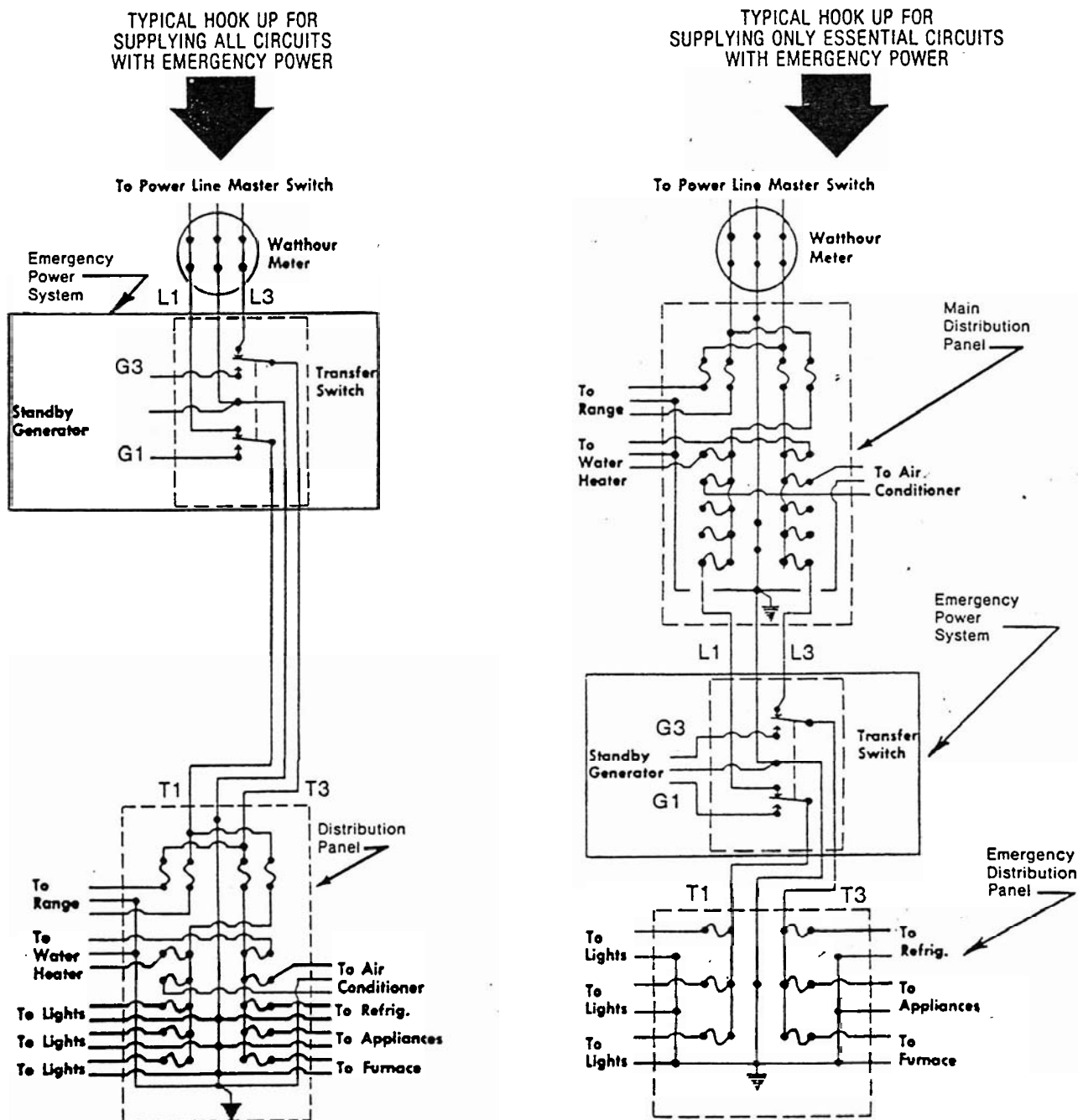

Figure 6

Maintenance

GENERAL

Routine preventive maintenance minimizes costly repairs and generator down-time. Before each use, inspect the generator: gear case oil level should be correct, cooling vents and screens should be clear, and generator mounting hardware should be tight. Clean and inspect the generator after storing it for long periods, and after using it in extremely dusty conditions or in severe weather, such as rain or blowing snow.

CAUTION: The manufacturer strongly recommends running the generator under load at least once a month in order to evaporate any accumulated moisture condensation.

LUBRICATION

The generator bearings are factory lubricated and sealed, and require no further lubrication.

Splined generator input shaft should be cleaned and lubricated with a thin film of grease before and after each use of the generator.

Coupling shaft (tumbling bar) requires greasing. Keep the universal joints in the coupling shaft free from grease and dirt buildup.

CAUTION: Do not overlubricate the universal joints.

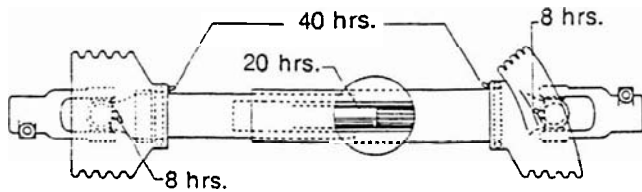

Figure 7

Lubrication for Typical Tumbling Bar (Coupling Shaft)

See Figure 7 for recommended lubrication schedule for tumbling bar.

Check the generator gear case oil level before each use of the generator. Maintain the oil level at oil level plug height. Figure 5 illustrates oil level plug location. The generator is shipped with lubricant in the gear case. Specifications for gear case lubricant are:

API Service: GL-5
Grade: SAE 85W-90-140
Amount: 1 quart

The following kinds of oil are recommended for use in the generator gear case: Mobil SAE 85W-90-140 API Service GL-5, Sunoco/DX XL80-90-140, Kendal Three Star 85W-140, Amoco 85W-140, or equivalent.

CAUTION: Do not overfill generator gear case. Overfilling causes overheating and oil seal failure.

Change the oil at least once every six months. Change it more often if you use the generator in bad weather.

Use the following procedure to change generator gear case oil. (See Figure 5).

1. Remove gear case breather. Soak breather in cleaning solvent, then allow it to dry.
2. Remove oil level check plug.
3. Remove the oil drain plug. Drain the oil into a clean oil resistant container, one quart or more capacity. Check the oil for metal. Fine metal dust in the oil does not indicate trouble, but metal chips do. Dismantle the gear case and look for damaged gears if you find metal chips in the oil.
4. Replace the oil drain plug. Refill the gear case through the breather port with new oil of the recommended type. Fill the case up to oil level check plug height. (It will take about one quart.)
5. Replace the oil level check plug.
6. Replace the breather.

CLEANING AND INSPECTING

Use a vacuum cleaner or dry low pressure compressed air (regulated at 25-35 PSI) to clean the generator periodically.

WARNING: DO NOT CLEAN THE GENERATOR WHILE IT IS RUNNING.

Proceed as follows:

1. Remove control box cover. Vacuum or blow dust or debris from the control box. Inspect all wiring for correct routing, fraying insulation, and secure connections.
2. Remove end cover. Vacuum or blow dust and debris from the inside of the generator. Inspect wiring for loose connections, fraying insulation and correct routing.
3. Replace end cover and control box cover.

GENERATOR STORAGE

Before storing the generator, apply a heavy coat of grease to the splined input shaft. Store the generator in sheltered area, where it is protected against snow, rain, and excessive dust.

BRUSHES

Under ordinary circumstances, brushes will operate for long periods without requiring replacement. They should be inspected after the first 1000 hours of operation, and after every 100 hours of operation thereafter. Remove brushes one at a time and check for length; be sure that each moves freely in the brush holder. Brushes should be replaced when worn down to 3/8". Replace brushes in complete sets, never singly. When replacing brushes, be careful to reconnect the lead wires properly.

Poor contact (or "skipping") between brush and slip-ring is caused by oil and grit, on the slip-ring, or a hard substance in the brush. It can also be caused by the brush not being properly seated or contoured to the slip-ring. To correct this discrepancy, the brushes can be recontoured by placing 00 sandpaper under the brushes with the abrasive side to the brushes, and work it back and forth until the brushes are seated to the slip-rings.

Maintenance (Continued)

COLLECTOR RINGS/SLIP RINGS

The continuous copper rings located at the end of the armature are the collector rings. For proper generator output, the surface of the collector rings must have a highly polished finish. Polish the ring surfaces occasionally with a crocus cloth to maintain the finish.

Testing

ARMATURE FOR OPENS AND GROUNDS

1. Remove all brushes.
2. **Grounding Test (See Figure 8).**
Set multimeter to read resistance. Holding one meter lead against a clean spot on the armature shaft, touch the other lead to each of the slip rings (one at a time) while observing the meter. If meter indicates continuity (zero ohms or any reading lower than infinite resistance), the armature is grounded.
3. **Testing for Opens (See Figure 8).**
(Meter still set to read resistance.) Holding one meter lead on surface of slip ring No. 1, touch other meter lead to surface of slip ring No. 2 while observing the meter. Meter should indicate continuity (low resistance). If not (i.e. if meter indicates infinite resistance) part of armature windings are open and armature should be replaced.
4. Check for open between slip rings No.'s 2 and 3 in same manner as you did between rings 1 and 2 (previous paragraph).

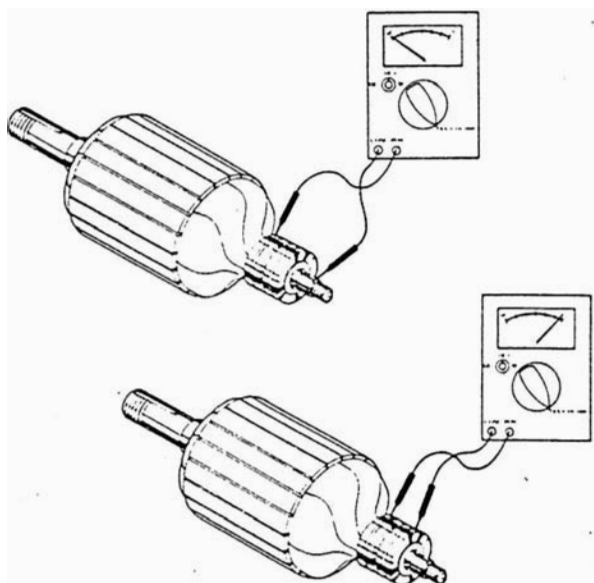

Figure 8
TESTING ARMATURE FOR OPENS AND GROUNDS

GENERATOR FIELD FOR OPENS AND GROUNDS (See Figure 9).

1. Disconnect field leads from rectifier.
2. Set multimeter to read resistance, and connect the meter leads to the field leads. If field is open, meter will read infinite resistance. Replace field if it is open.
3. Connect one meter lead to the field shell (other lead still connected to one of the field leads). If meter indicates continuity (zero ohms or any reading lower than infinite resistance), the field is grounded and should be replaced.

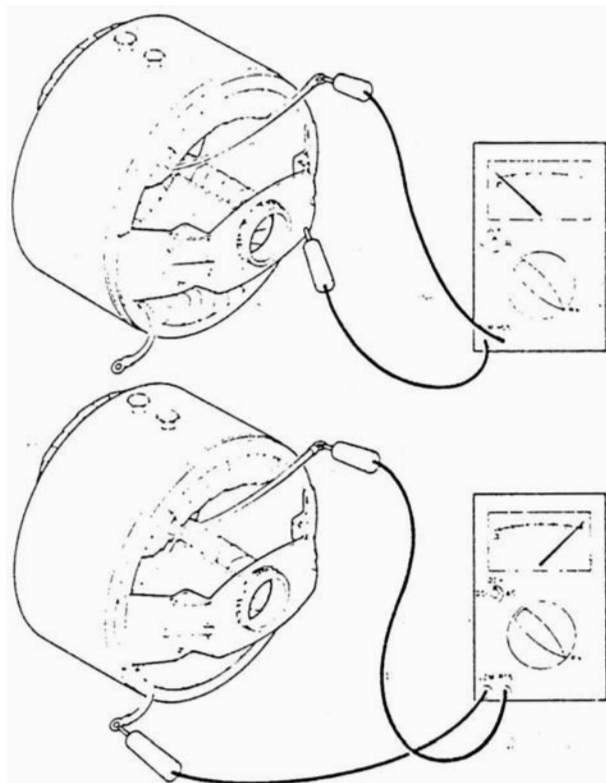

Figure 9 **FIELD COIL TESTING**

RECTIFIERS (See Figure 10)

The Field Excitation rectifier is a full-wave bridge rectifier. This type of rectifier has four terminals, Two AC, a DC positive, and a DC negative. The rectifier is tested in the following manner. Connect one ohmmeter lead to the positive DC terminal, and the other lead to each of the AC terminals in turn. A high or low resistance reading will be obtained. Reverse the meter leads, and an opposite reading should be observed. Now check from the negative terminal to each of the AC terminals, using the same procedures as above.

Check each terminal to the case, and no resistance reading should be observed.

If a battery-powered test light is used, follow the procedures described above. If the rectifier is good, the light will come on in one direction only.

If the rectifier fails any of the above tests, it should be considered defective and replaced.

Maintenance (Continued)

CONDENSER

Condensers are built into the generator circuit to minimize radio interference during operation. If a condenser shorts out, it shorts the generator output. To determine whether a condenser is shorted, stop the generator, disconnect the lead wire from the brush holder to which the condenser is connected, start the generator and check the output. If the generator then provides power, the condenser was at fault and should be replaced. (If the generator did not provide power after the lead wire was disconnected the problem was not caused by that condenser. Reconnect the lead wire.)

RED (+) TEST LEAD

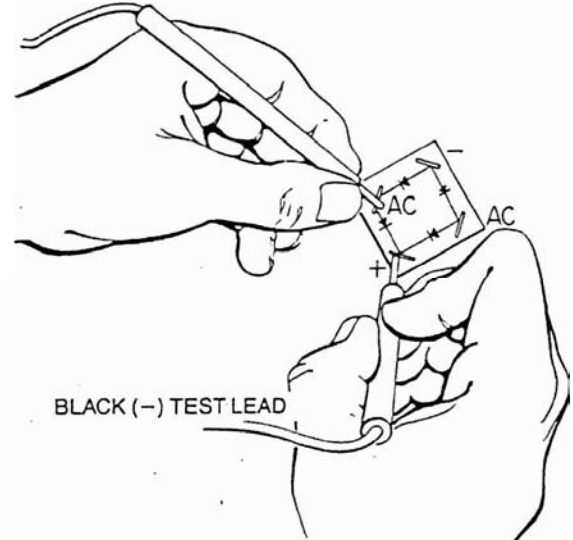

BLACK (-) TEST LEAD

Figure 10

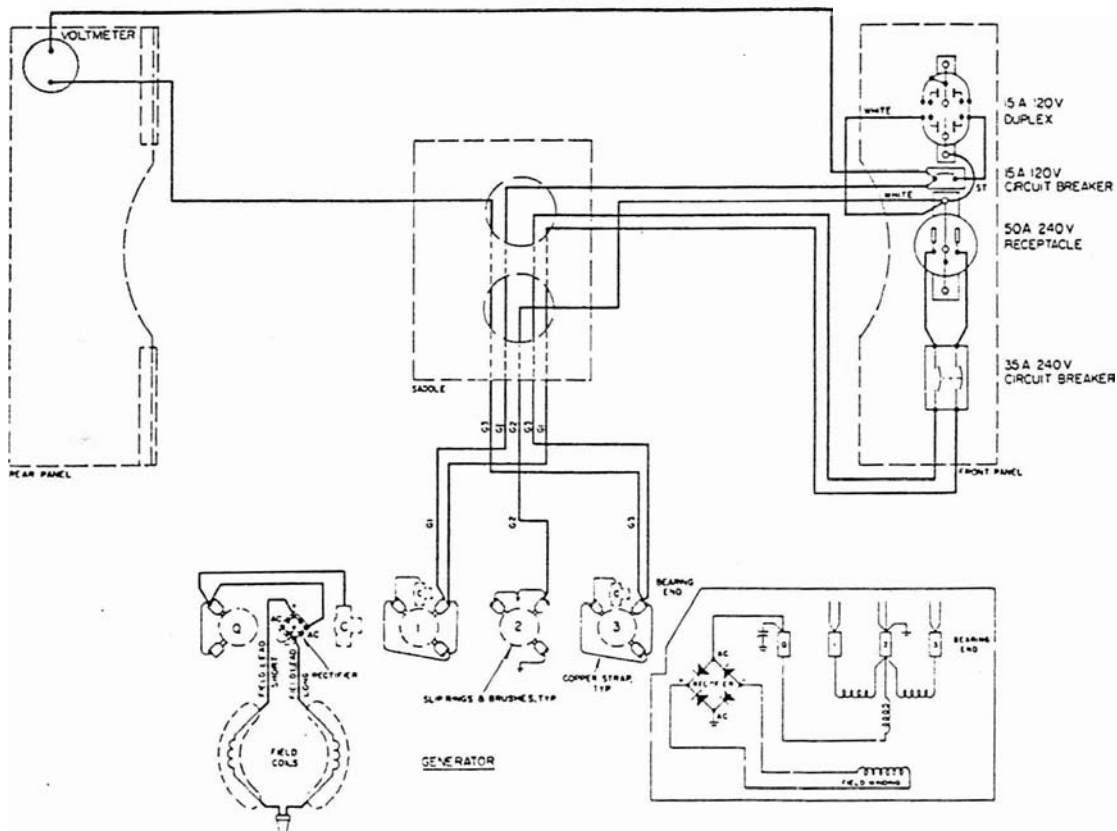

CSA8PTOC-3/C

Figure 11 — Wiring Diagram Model

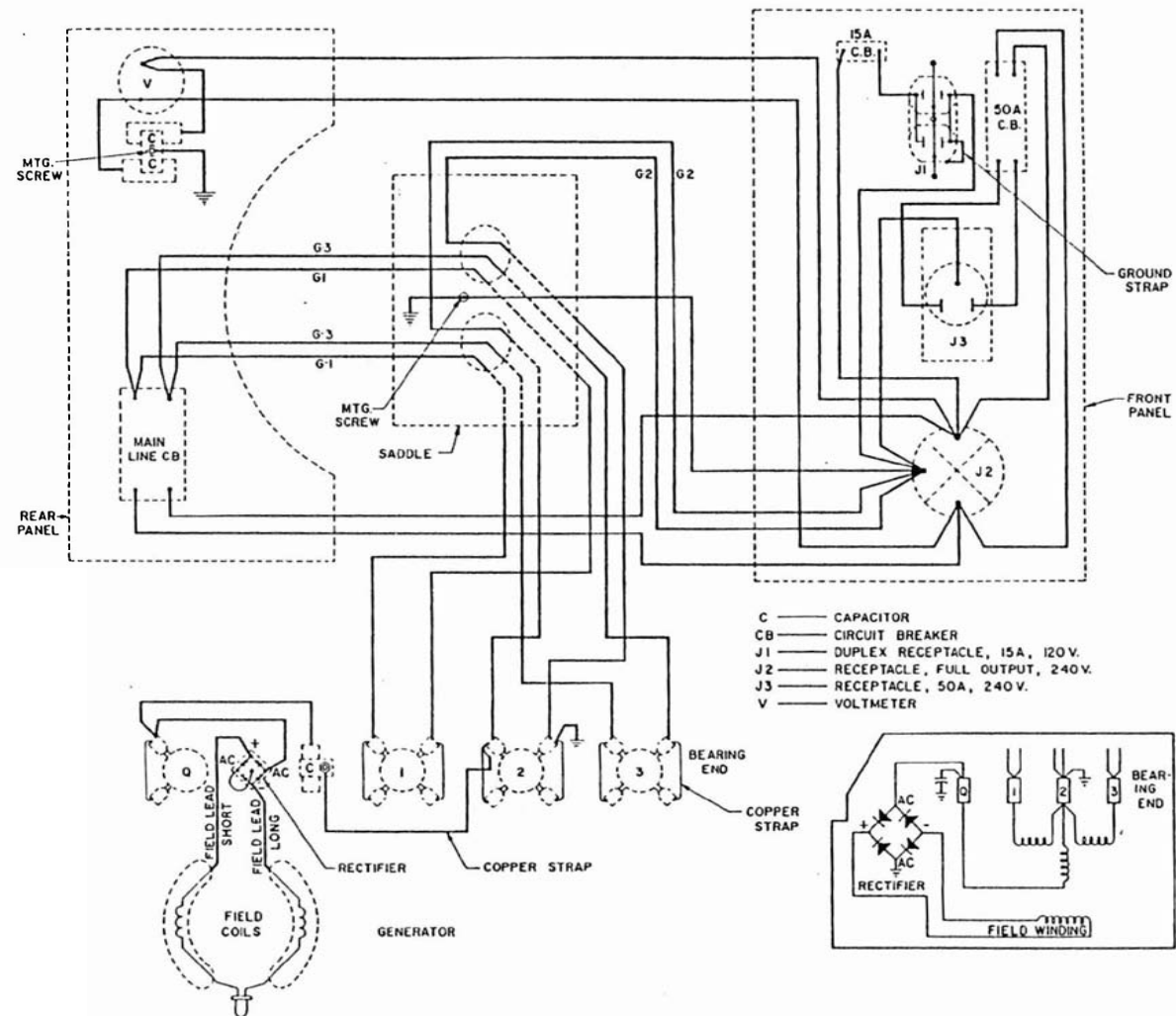

25PTOC-3/F

Figure 12 — Wiring gram Model

CSA8PTOC-3/C

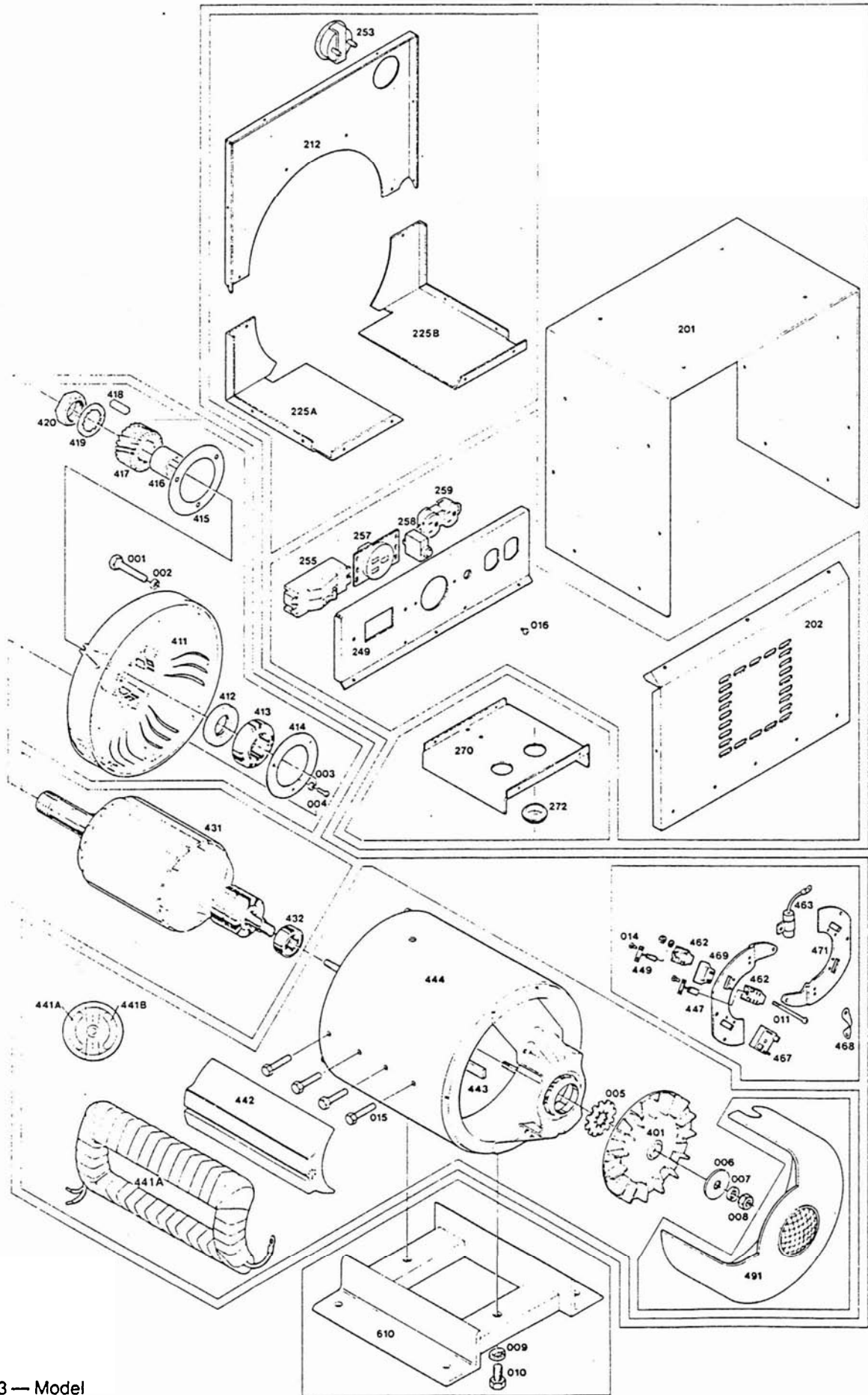

Figure 13 — Model

Replacement Parts List for Model ..CSA8PTOC-3/C

Ref. No.	Part No.	Qty.	Description	Ref. No.	Part No.	Qty.	Description
001	51101	4	Machine screw	272	23917	2	Grommet
002	480	4	Lockwasher - 5/16 split	401	23404	1	Fan assembly
003	479	3	Lockwasher - 1/4 split	411	51046-1	1	End bracket
004	45633	3	Screw - 1/4-20 x 5/8	412	46912	1	Oil seal
005	40552	1	Lockwasher - 11/16 int.	413	46913	1	Bearing
006	21867	1	Washer - 1/2 flat	414	44318	1	Retainer plate
007	20039	1	Lockwasher - 1/2 ext.	415	20136	1	Gasket
008	9549	1	Nut - 1/2-20 x 3/8	416	20137	1	Spacer
009	636	2	Lockwasher - 1/2 split	417	46545	1	Pinion gear
010	48178	2	Cap screw - 1/2-13 x 1	418	20159	1	Key
011	10888	6	Machine screw - #8-32 x 2-1/2	419	20139	1	Lockwasher - 1-1/4 int. tooth
014	40746	22	Machine screw - #8-32 x 5/16	420	20160	1	Nut, 1-1/4-12
015	91658-4	6	Cap screw - 3/8-16 x 1-3/4	431	60851	1	Armature assembly-less bearings
016	21698-1	25	Screw	432	50215	1	Bearing
201	60944-2	1	Cover	441A	60852	1	Field coil
202	60982-3	1	Front cover	441B	60852-1	1	Field coil
212	61144	1	Upper rear panel only	442	42882	2	Pole shoe
225A	61216-1	1	Lower rear panel (left)	443	42883	2	Pole shoe retainer
225B	61216-2	1	Lower rear panel (right)	444	59977	1	Field shell and brkt
249	61109	1	Front panel only	447	53636	9	Brush A.C. (1/4 x 3/8)
253	52490	1	Voltmeter	449	53949	2	Brush "Q" (1/4 x 3/8)
255	57030-3	1	Breaker - 2 pole 35 amp	462	59690	11	Brush holder A.C.
257	57325	1	Receptacle-250 V / 50 amp (x-50R)	463	41221	3	Capacitor A.C.
258	91598	1	Circuit breaker- 1 pole 15 amp	467	91452	1	Rectifier
259	24749	1	Receptacle - 120V/ 15 amp (5-15R)	468	41387-6	3	Ground strap - copper
270	60951	1	Saddle	469	59688	11	Barrier spacer
				471	56960	2	Brush plate (bare)
				491	55007	1	End cover
				610	51147	1	Base assembly

Replacement Parts List

Ref. No.	Part No.	Qty.	Description
130	55475	1	Gear box assembly
134	46547	1	Pinion gear (540 rpm)
137	20029	1	Seal (input shaft)
138	54666	2	Bearing
140	46296	1	Shaft (input drive)
141	1774	4	Woodruff key
142	46548	1	Gear (540 rpm input)
144	20016	1	Gasket - cover
146	56207	1	Backing plate
147	53332	1	Safety shield
148	46546	1	Gear (driven-540 rpm)
149	54665	2	Bearing
150	46299	1	Gasket
151	46295	1	Retainer
152	46298	1	Gasket
153	46286	1	Retainer
154	20133	1	Snap ring
155	55476	1	Gear case & cover only
156	40716	1	Breather
157	20128	1	Shaft (intermediate driven)
158	4133	1	Roll pin
159	24142	1	Street elbow, 90°

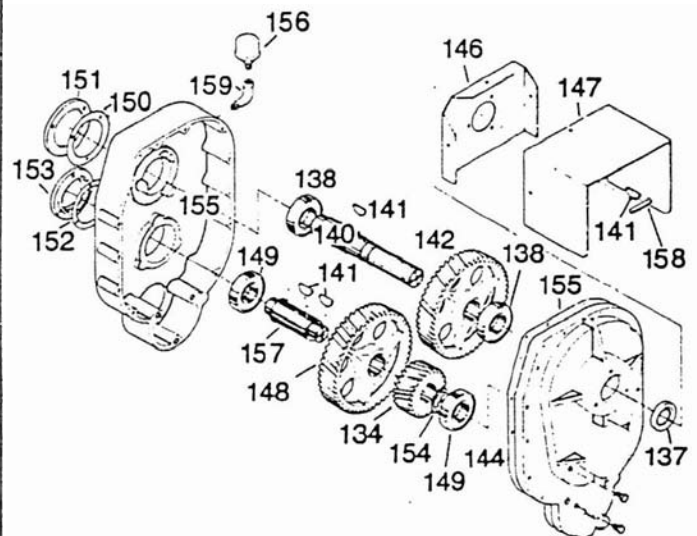

Figure 14 — Gearbox

25PTOC-3/F

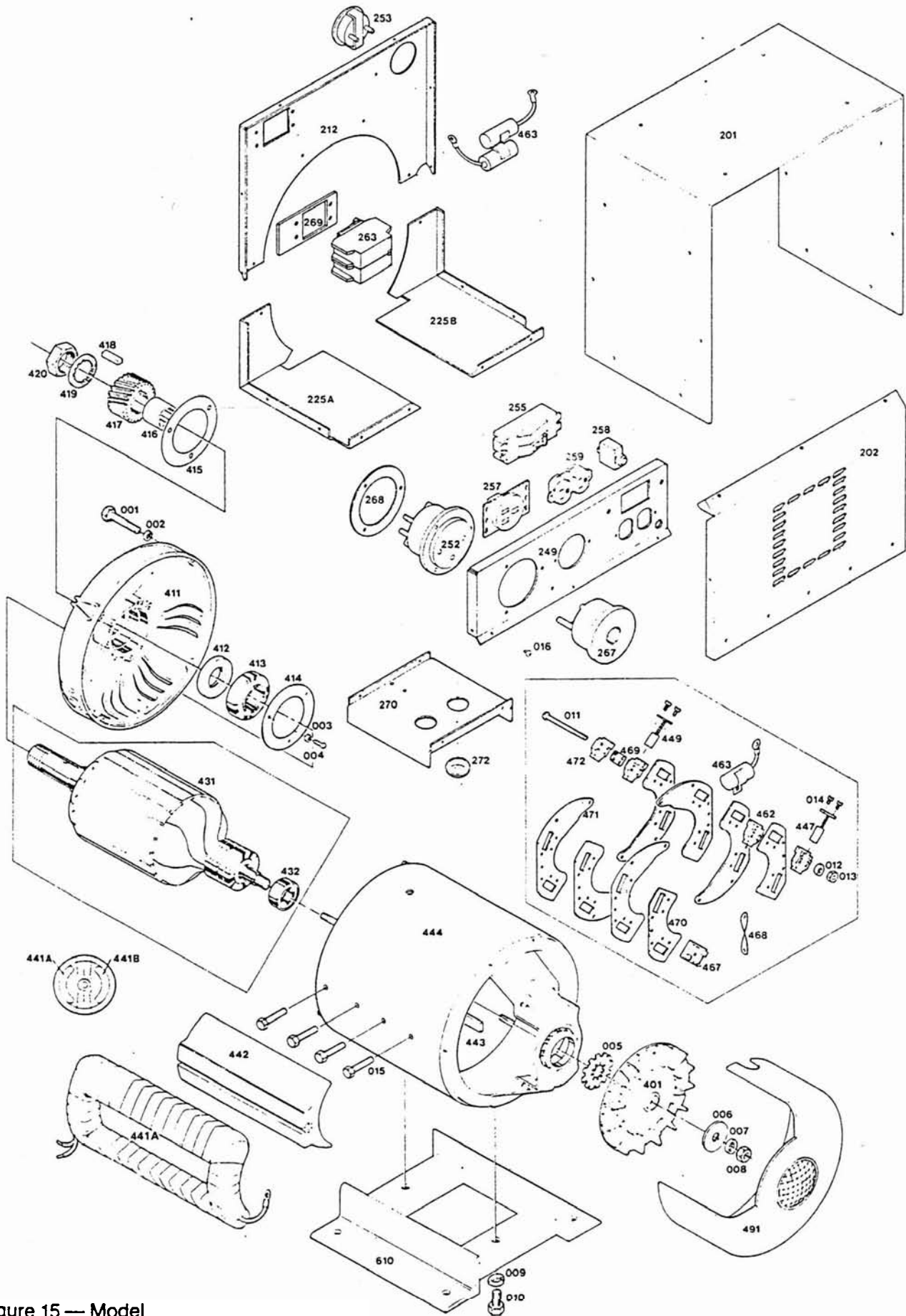

Figure 15 — Model

Replacement Parts List for Model 25PTOC-3/F

Ref. No.	Part No.	Qty.	Description	Ref. No.	Part No.	Qty.	Description
001	51101	4	Machine screw	269	58805-1	1	Circuit breaker mtg plte
002	480	4	Lockwasher - 5/16 split	270	60951	1	Saddle
003	479	3	Lockwasher - 1/4 split	272	23917	2	Grommet
004	45633	3	Screw - 1/4-20 x 5/8	401	23404	1	Fan assembly
005	40552	1	Lockwasher - 11/16 int.	411	51046-1	1	End bracket
006	21867	1	Washer - 1/2 flat	412	46912	1	Oil seal
007	20039	1	Lockwasher - 1/4 ext.	413	46913	1	Bearing
008	9459	1	Nut - 1/2-20 x 3/8	414	44318	1	Retainer plate
009	636	2	Lockwasher - 1/2 split	415	20136	1	Gasket
010	48178	2	Cap screw - 1/2-13 x 1	416	20137	1	Spacer
011	44342	8	Machine screw - #8-32 x 3	417	46545	1	Pinion gear
012	6376	3	Lockwasher - #8	418	20159	1	Key
013	5113	3	Nut - #8-32	419	20139	1	Lockwasher- 1-1/4 int. tooth
014	40746	28	Machine screw - #8-32 x 5/16	420	20160	1	Nut, 1-1/4-12
015	43781	8	Cap screw - 7/16 x 1-3/4	431	52497-1	1	Armature assembly- less bearings
016	21698-1	25	Screw	432	50215	1	Bearing
201	60944-2	1	Cover	441A	52563	1	Field coil
202	60982-3	1	Front cover	441B	52563-1	1	Field coil
212	61111	1	Upper rear panel only	442	43473	2	Pole shoe
225A	61216-1	1	Lower rear panel (left)	443	43474	2	Pole shoe retainer
225B	61216-2	1	Lower rear panel (right)	444	61153	1	Field shell and brkt
249	61110	1	Front panel only	447	24981	12	Brush A.C. (3/8x3/8)
252	91333	1	Receptacle	449	53949	2	Brush "O" (1/4x3/8)
253	52490	1	Voltmeter	462	23500-2	12	Brush holder A.C.
255	57030	1	Breaker - 2 pole 50 amp	463	41221	3	Capacitor A.C.
257	57325	1	Receptacle-250 V / 50 amp (x-50R)	467	91452	1	Rectifier
258	91286	1	Circuit breaker- 1 pole 15 amp	468	41387-6	1	Ground strap - copper
259	24749	1	Receptacle- 120V/15 amp (5-15R)	469	23532	14	Fiber spacer
263	58805-2	1	Circuit breaker - 2 pole 100amp	470	52559	2	Spacer-brush holder
267	91357	1	Main disconnect plug	471	53975	6	Brush mounting plate segment (bare)
268	91350	1	Receptacle mounting plate	472	23500	2	"O" ring brush holder
				491	55007	1	End cover
				610	51147	1	Base assembly

Replacement Parts List

Ref. No.	Part No.	Qty.	Description
130	55475	1	Gear box assembly
134	46547	1	Pinion gear (540 rpm)
137	20029	1	Seal (input shaft)
138	54666	2	Bearing
140	46296	1	Shaft (input drive)
141	1774	4	Woodruff key
142	46548	1	Gear (540 rpm input)
144	20016	1	Gasket - cover
146	56207	1	Backing plate
147	53332	1	Safety shield
148	46546	1	Gear (driven-540 rpm)
149	54665	2	Bearing
150	46299	1	Gasket
151	46295	1	Retainer
152	46298	1	Gasket
153	46286	1	Retainer
154	20133	1	Snap ring
155	55476	1	Gear case & cover only
156	40716	1	Breather
157	20128	1	Shaft (intermediate driven)
158	4133	1	Roll pin
159	24142	1	Street elbow, 90°

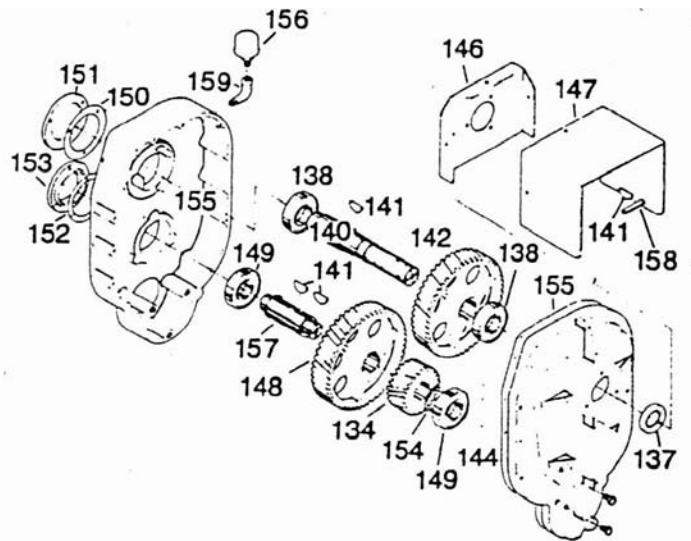

Figure 16 — Gearbox

Trouble Shooting Chart

GENERAL

The following chart lists various symptoms of poor generator operation with possible causes for them and the appropriate corrective action. You will need a volt-ohm meter or test light to check some of the causes. For some of the other causes you will need to check generator speed. To check speed use a frequency meter, a tachometer, or a 120V-60Hz electric clock and a correctly operating wrist watch. (Run the electric clock on generator power and

compare the clock's second hand movement with that of the wrist watch. They should run at the same speed. If clock runs faster, generator speed is too high, and vice versa).

CAUTION: Most electrical equipment in North America operates at frequencies between 59 and 61 Hz (CPS). Operating the generator at frequencies outside that range may cause damage to the generator and/or to electrical equipment driven by the generator.

SYMPTOM	CAUSE(S)	CORRECTIVE ACTION
No output voltage.	<ol style="list-style-type: none"> 1. Circuit breaker. 2. Defective voltmeter. 3. Short circuit in the load. 4. Defective receptacles. 5. Loose (or broken) wires or connections in the control box. 6. Defective rectifier. 7. Dirty slip rings. 8. Brushes binding in holders. 9. Shorted or open armature. 10. Shorted or open field coils. 	<ol style="list-style-type: none"> 1. Reset circuit breakers; replace if defective. 2. Check output with another meter, replace meter if defective. 3. Disconnect the load. Check voltage at receptacle. Check motors, appliances and load leads for short circuit. Repair short. 4. Remove panel cover and check for voltage to the receptacles. Replace defective receptacles. 5. Remove panel cover and check all wiring and connections. Tighten and/or repair where necessary. 6. Test rectifier. Replace if defective. 7. Clean and polish. Use 00 sandpaper and crocus cloth, never emery paper. 8. Check brushes for swelling; replace defective brushes; clean brush holders. 9. Replace armature if open or shorted. 10. Measure between leads for open or short. Replace coil(s) if defective.
Low voltage.	<ol style="list-style-type: none"> 1. Engine speed too slow. Generator overloaded. 2. Inadequate engine horsepower. 3. Incorrect field excitation. 4. Brushes not seated properly, or dirty brushes and slip rings. (Remove brushes; check for uneven wear or dirt on brushes or slip rings.) 	<ol style="list-style-type: none"> 1. Check engine speed. Increase RPM if necessary. Reduce load if it is higher than the rated capacity of the operator (See generator nameplate.) 2. Generator requires 2.2 H.P./1000 watts output. Obtain larger engine if necessary. 3. Check input AC voltage to rectifier. Check rectifier output DC voltage. 4. Clean slip rings and seat brushes with sandpaper. (See Maintenance).
High voltage.	Engine speed too fast.	Check engine speed for correct input RPM.
Output voltage flickering or fluctuation.	<ol style="list-style-type: none"> 1. Tumbling bar (coupling shaft) misalignment. 2. Engine speed not constant. 3. Loose connection in field circuit. 4. Tumbling bar U-joints not synchronized. 	<ol style="list-style-type: none"> 1. Reduce tumbling bar misalignment to less than 15 degrees. 2. Engine governor may be worn or improperly adjusted. Set or repair defective governor. 3. Check and tighten connections. 4. Reassemble tumbling bar.
Excessive vibration.	<ol style="list-style-type: none"> 1. Power take-off misalignment excessive. 2. Loose mounting nuts and bolts or hold-down studs. 3. Universal joints in coupling shaft worn or dry. 4. Defective bearings. 	<ol style="list-style-type: none"> 1. Correct misalignment. It should be less than 15 degrees. 2. Tighten mounting nuts and bolts; repair hold-down stud mountings. 3. Repair or replace defective parts. 4. Check for possible causes. Replace defective bearings.
Generator overheating.	<ol style="list-style-type: none"> 1. Poor ventilation. 2. Generator overloaded. 3. Shorted turns in field or armature. 	<ol style="list-style-type: none"> 1. Clean ventilation and cooling fan screens. 2. Reduce load, then check voltage and current. 3. Replace defective components.
Oil leak.	<ol style="list-style-type: none"> 1. Loose plug in gear case. 2. Defective seal, gasket, or plug in gear case. 	<ol style="list-style-type: none"> 1. Tighten plug. 2. Replace seal(s), gaskets or plugs. Maintain correct oil level.

Service Record

DATE	MAINTENANCE PERFORMED	REPLACEMENT COMPONENTS REQUIRED

Limited Warranty for PTO Generators

Winco warrants that for thirty-six months from date of shipment it will repair or replace for the original user the whole or any part of the product found upon examination by Winco at its factory at 225 South Cordova Avenue, LeCenter, Minnesota, or by any Factory-Authorized Service Station to be defective in material or workmanship under normal standby use (average less than 50 hours per month) and service.

For warranty service, please return the product within one year from date of shipment, transportation charges prepaid, to the Winco factory or to your nearest Factory-Authorized Service Station as listed in the 'Yellow Pages' under Generator-Electric.

THERE IS NO OTHER EXPRESS WARRANTY, TO THE EXTENT PERMITTED BY LAW, ANY AND ALL IMPLIED WARRANTIES, INCLUDING THOSE OF MERCHANTABILITY AND FITNESS FOR A PARTICULAR PURPOSE, ARE LIMITED TO THIRTY-SIX MONTHS FROM DATE OF SHIPMENT, AND LIABILITY FOR INCIDENTAL OR CONSEQUENTIAL DAMAGES OR EXPENSES IS EXCLUDED. Some states do not allow limitations on the duration of an implied warranty, and some states do not allow the exclusion or limitation of incidental or consequential damages, so the above limitation or exclusion may not apply to you. This warranty gives you specific legal rights; you may have other rights which vary from state to state.

Winco does not warrant trailer tires, tumbling bars, or certain other component parts of the product since such items are warranted by their manufacturers.

Winco does not warrant alterations or repairs which were made by someone other than the Winco factory or a Factory-Authorized Service Station and which affect the stability or reliability of the product.

Winco does not warrant products which have been exposed to misuse and/or negligence or have been involved in an accident.

Winco reserves the right to change or improve its products without incurring any obligations to make such changes or improvements on products purchased previously.

WINCO[®]
INCORPORATED

Manufacturing-Engineering & Customer Service
225 South Cordova Avenue
Le Center, MN 56057 • (612) 357-6821