



# PACKAGED STANDBY SYSTEM

---

## INSTALLATION AND OPERATORS MANUAL

### PSS12H2W/D

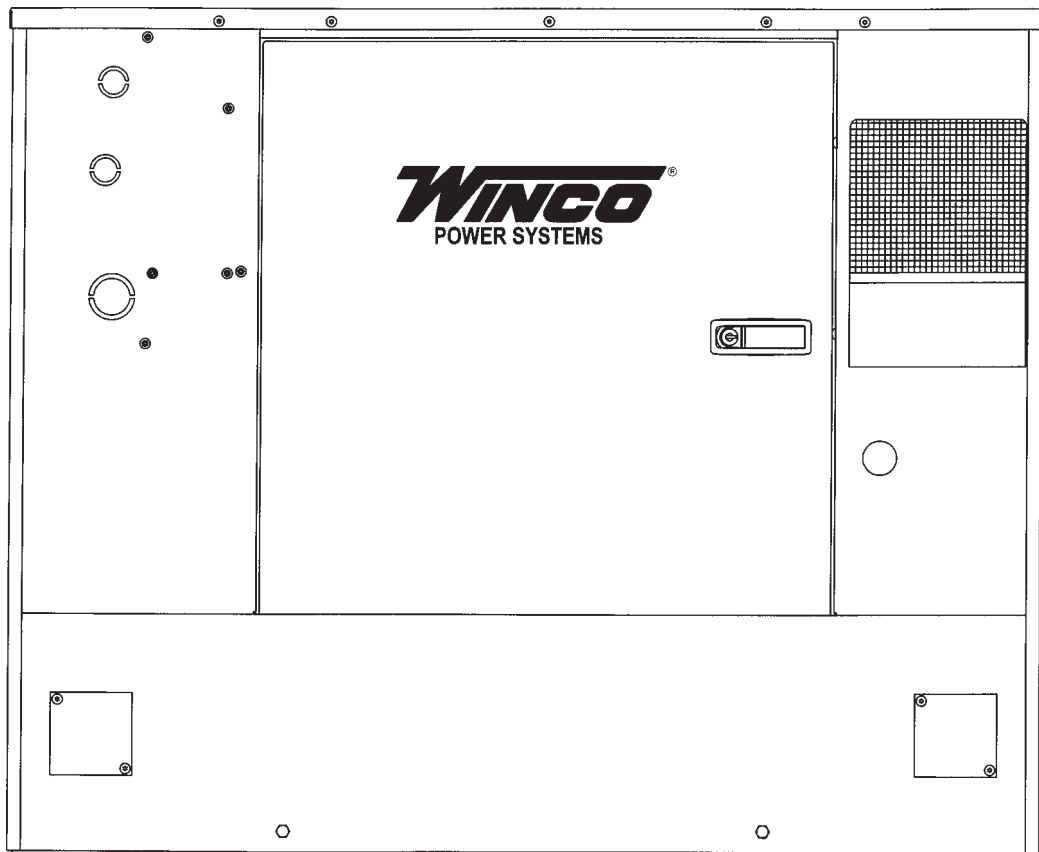

**SAVE THESE INSTRUCTIONS**

# SAVE THESE INSTRUCTIONS

This manual contains important instructions that should be followed during installation and maintenance of the generator and batteries.

Read and understand all instructions in the manual before starting and operating the generator set.

## USING THIS MANUAL

Congratulations on your choice of a Winco generator set. You have selected a high-quality, precision-engineered generator set designed and tested to give you years of satisfactory service.

To get the best performance from your new engine generator set, it is important that you carefully read and follow the operating instructions in this manual.

Should you experience a problem please follow the "Things To Check" near the end of this manual. The warranty listed in this manual describes what you can expect from WINCO should you need service assistance in the future.

## TABLE OF CONTENTS

INTRODUCTION	i
GUIDE TO PRODUCT SAFETY	1
<b>BASIC INFORMATION</b>	2
Description	2
Specification Table	2
<b>PREPARING THE UNIT</b>	3
Unpacking the Unit	3
<b>ENGINE GENERATOR INSTALLATION</b>	3
Installation	3
Fuel Installation	4
Vapor Fuel Pressure Tables	5
Fuel Conversions	5
Lubrication	5
Battery Installation	6
Connecting Battery Charger	7
<b>TRANSFER SWITCH INSTALLATION</b>	7
AC Electrical Connections	7
DC Electrical Connections	9
<b>INITIAL START-UP</b>	10
<b>TROUBLESHOOTING INFORMATION</b>	12
<b>PREVENTIVE MAINTENANCE</b>	13
<b>WIRING DIAGRAMS</b>	
AC & DC Generator Schematic	14
UL ATS Wiring Diagram	15
Generator Layout	16
<b>12 MONTH WARRANTY</b>	17
<b>MAINTENANCE LOG</b>	18

# PROPER USE AND INSTALLATION

You must be sure your new engine generator set is:

- \* Properly serviced before starting
- \* Operated in a well ventilated area
- \* Properly exhausted and gases safely dispersed
- \* Wired by a qualified electrician
- \* Operated only for its designed purposes
- \* Used only by operators who understand its operation
- \* Properly maintained

## COPY YOUR MODEL AND SERIAL NUMBER HERE

No other WINCO generator has the same serial number as yours. It is important that you record the number and other vital information here. If you should ever need to contact us on this unit it will help us to respond to your needs faster.

MODEL \_\_\_\_\_

SERIAL NUMBER \_\_\_\_\_

PURCHASE DATE \_\_\_\_\_

DEALER \_\_\_\_\_

DEALER PHONE # \_\_\_\_\_

# SAFETY INFORMATION

This engine generator set has been designed and manufactured to allow safe, reliable performance. Poor maintenance, improper or careless use can result in potential deadly hazards; from electrical shock, exhaust gas asphyxiation, or fire. Please read all safety instructions carefully before installation or use. Keep these instructions handy for future reference. Take special note and follow all warnings on the unit labels and in the manuals.

## ANSI SAFETY DEFINITIONS

\*\*\*\*\*

### DANGER:

*DANGER indicates an imminently hazardous situation which, if not avoided, will result in death or serious injury. This signal word is to be limited to the most extreme situations.*

\*\*\*\*\*

\*\*\*\*\*

### WARNING:

*WARNING indicates a potentially hazardous situation which, if not avoided, could result in death or serious injury.*

\*\*\*\*\*

\*\*\*\*\*

### CAUTION:

*CAUTION indicates a potentially hazardous situation which, if not avoided, may result in minor or moderate injury. It may also be used to alert against unsafe practices.*

\*\*\*\*\*

### NOTE:

*CAUTION is also used on the unit labels and in this manual to indicate a situation that could result in serious damage or destruction of the equipment and possible personal injury.*

**1. ELECTRIC SHOCK** - The output voltage present in this equipment can cause a fatal electric shock. This equipment must be operated by a responsible person.

- a. Do not allow anyone to operate the generator without proper instruction.
- b. Guard against electric shock.
- c. Avoid contact with live terminals or receptacles.
- d. Use extreme care if operating this unit in rain or snow.
- e. Use only three-prong grounded receptacles and extension cords.
- f. Be sure the unit is properly grounded to an external ground rod driven into the earth.

**2. FIRE HAZARD** - Natural gas and L.P. present a hazard of possible explosion and/or fire.

- a. Do not refuel when the engine is running or hot.

Allow the engine to cool at least two minutes before refueling.

- b. Keep fuel containers out of reach of children.
- c. Do not smoke or use open flame near the generator set or fuel tank.
- d. Keep a fire extinguisher nearby and know its proper use. Fire extinguishers rated ABC by NFPA are appropriate.
- e. Store fuel only in an approved container, and only in a well-ventilated area.
- f. Follow local codes for closeness to combustible material.

**3. DEADLY EXHAUST GAS** - Exhaust fumes from any gasoline engine contain carbon monoxide, an invisible, odorless and deadly gas that must be mixed with fresh air.

- a. Operate only in well ventilated areas.
- b. Never operate indoors.
- c. Never operate the unit in such a way as to allow exhaust gases to seep back into closed rooms (i.e. through windows, walls or floors).

**4. NOISE HAZARD** - Excessive noise is not only tiring, but continual exposure can lead to loss of hearing.

- a. Use hearing protection equipment when working around this equipment for long periods of time.
- b. Keep your neighbors in mind when permanently installing this equipment.

**5. CLEANLINESS** - Keep the generator and surrounding area clean.

- a. Remove all grease, ice, snow or materials that create slippery conditions around the unit.
- b. Remove any rags or other material that could create potential fire hazards.
- c. Carefully clean up any gas or oil spills before starting the unit.
- d. Never allow leaves or other flammable material to build up around the engine intake or exhaust area.

**6. SERVICING EQUIPMENT** - All service, including the installation or replacement of service parts, should be performed only by a qualified technician.

- a. Use only factory approved repair parts.
- b. Do not work on this equipment when fatigued.
- c. Never remove the protective guards, cover, or receptacle panels while the engine is running.
- d. Use extreme caution when working on electrical components. High output voltages from this equipment can cause serious injury or death.
- e. Always avoid hot mufflers, exhaust manifolds, and engine parts. They all can cause severe burns instantly.
- f. Installing a generator set is not a "do-it-yourself" project. Consult a qualified, licensed electrician or contractor. The installation must comply with all national, state, and local codes.

# TESTING POLICY:

Before any generator is shipped from the factory, it is fully checked for performance. The generator is loaded to its full capacity, and the voltage, current, and frequency are carefully checked.

Rated output of generators is based on engineering tests of typical units, and is subject to, and limited by, the temperature, altitude, fuel, and other conditions specified by the manufacturer of the applicable engines.

## INTRODUCTION AND DESCRIPTION

The package standby system includes all items necessary for a completely automatic standby power system as standard equipment.

### DESCRIPTION

This packaged standby system is designed to automatically provide standby power to unattended loads during electrical outages. Upon an interruption of normal electrical service the packaged standby system electrical control circuits will automatically start the engine. The generator will produce electrical power and the Automatic Transfer Switch (A.T.S.) will automatically transfer the electrical loads to the engine-generator set. Upon restoration of normal electrical service the emergency transfer switch will sense return of the normal commercial power. The Automatic Transfer Switch will retransfer the load back to the normal commercial power source. The engine control circuits will begin a cool-down cycle, after which the fuel supply will be shut off and the engine ignition system disabled.

These packaged standby systems consist of two major components:

### 1) AUTOMATIC TRANSFER SWITCH

A wall mounted Automatic Transfer Switch (A.T.S.) designed for inside installation. A fourteen day electronic exerciser clock is installed in the A.T.S. as standard equipment. The A.T.S. also contains the power failure sensing circuitry necessary to send a start/stop signal to the engine generator set.

#### UL Automatic Transfer Switch Sizes

UNIT	LINE SIDE CONTACTOR	GENERATOR SIDE CONTACTOR
PSS12H	100 AMPS	100 AMPS
	200 AMPS	200 AMPS

Both the 100 amps and the 200 amps UL Switches are available in single and three phase.

Additional optional A.T.S. sizes are available to meet specific needs. Contact your local WINCO dealer, or the WINCO Sales Department for a quote.

## 2) ENGINE/GENERATOR

The engine generator set consists of a Honda, twin cylinder, four cycle air cooled engine. The engine is factory equipped to run on L.P. or N.G. fuel. The engine operates at 3600 rpm and frequency regulation is maintained by the engine governor within 4 cycles variation (62.5 Hz - 58.5 Hz) from no load to rated load. The generator is a brushless, single bearing, direct drive, rotating field design. The generator is connected to the engine's tapered (quill) crankshaft extension. The engine generator is mounted in a drip-proof enclosure for outside installation. Connection boxes and terminal blocks are provided for all customer connections (both AC output and DC control). A customer supplied 12 volt 500 CCA (BCI group 26) battery is required to complete the installation. Engine operation is controlled by an Electronic Engine Control Module (E.C.M.) mounted in the engine generator enclosure. The E.C.M. is equipped standard with a 10 second start delay, 90 second cool down delay and cycle cranking.

### \*\* NOTICE \*\*

*This unit will automatically transfer if a power outage occurs while running in an exercise mode.*

## SPECIFICATIONS

### GENERATOR

MODEL	WATTS*	VOLTS	AMPS*	HZ	PH	RPM
PSS12H	12,000	120/240	50.0	60	1	3600

\*Derate 16% for Natural Gas operation. Derate 3.5% per 1000 feet elevation above sea level.

### FUEL CONSUMPTION

MODEL	NG 1000 BTU/CU FT		L.P. VAPOR 2520 BTU/CUFT	
	CF/HR	BTU/HR	#/HR*	GAL/HR
PSS12H	190	190,000	9.0	2.10

\*Based on full load operation

### L.P. TANK SIZING

Required L.P. Tank size for L.P. Vapor withdrawal operating at various outside temperatures given in degrees Fahrenheit (Celsius)

MODEL	TANK TEMPERATURE			
	60 f(16 c)	32 f(0 c)	0 f(-18 c)	-20 f(-29 c)
PSS12H	150 Gal.	250 Gal.	500 Gal.	1000 Gal.

### ENGINE SPECIFICATIONS:

Refer to engine operating and maintenance instructions.

**\*\* NOTICE \*\***

*Regarding Engines - This manual covers the generator portion of these units. See the separate engine instruction manual for engine-related problems, detailed engine information and engine warranty.*

**\*\* CAUTION \*\***

*Be sure to check the engine oil level frequently, as specified in the engine manual.*

The engine manufacturer has established an excellent worldwide engine service organization; engine service is available from a nearby authorized dealer or distributor; check the yellow pages of the telephone directory under "engines," or ask the dealer from whom you purchased the power plant.

The rated power of each engine-generator is limited by the temperature, altitude and all other ambient conditions specified by the engine manufacturer. Engine power will decrease 3-1/2% for each 1000 ft. above sea level, and will decrease an additional 1% for each 10 degrees Fahrenheit above 60 degrees Fahrenheit. Units should not be operated in ambient temperature greater than 110 degrees Fahrenheit.

## UNPACKING INSTRUCTIONS

**\*\* NOTICE \*\***

*When unpacking the generator set, be sure to inspect it carefully for freight loss or damage. If loss or damage is noted at the time of delivery, require that the person making the delivery make note of the loss or damage on the freight bill, or affix his signature under the consignor's memo of the loss or damage. Contact the carrier for claim procedures.*

When loss or damage is noted after delivery, segregate the damaged material, and contact the carrier for claim procedures. Be sure to retain the packaging material for carrier inspection.

"Concealed Damage" is understood to mean damage to the contents of a package which is not evident at the time of delivery by the carrier, but which is discovered later. The carrier or carriers are responsible for merchandise lost or damaged in transit. The title to goods rests with the consignee when generators are shipped F.O.B. factory, and only the consignee can legally file a claim. Please note, most carriers have a time limit for filing concealed damage claims.

**\*\*\*\* CAUTION \*\*\*\***

*These units are shipped with oil. Be sure to check oil levels before operating. See engine manufacturer's instruction manual for recommended oil requirements before initial starting.*

## UNPACKING:

1. Carefully remove the carton.
2. After inspecting the engine-generator and transfer switch for external physical damage, check for the following items packed inside the carton.
  - a. Owner's manual, wiring diagram and parts list.
  - b. Engine manufacturer's instruction manual.
3. Remove main frame hold down bolts (4).
4. Unit can now be lifted from shipping pallet.

## INSTALLATION

### General Information

\*\*\*\*\*  
**\*\*\*\* WARNING \*\*\*\***  
\*\*\*\*\*

*Before proceeding with the installation, be sure the operation selector switch is in the stop position.*

**These engine/generator sets are designed to be mounted on a concrete pad outdoors only.** As an option a prefab pad maybe used as long as proper attention is paid to site preparation to insure the unit will not move after installations. The transfer switch is mounted next to your electrical entrance or distribution panel inside the building. Consult a qualified, licensed electrician or contractor to install and wire the transfer switch. **The installation must comply with all national, state and local codes.**

Before beginning the installation process recheck the rating of the generator set and its transfer switch rating. Be certain they can handle the intended load and are compatible with the entrance voltage, phase and current ratings. Plans for installation should be prepared with proper attention to mechanical and electrical engineering detail to assure a satisfactory system installation. The information in this manual is offered only as a guide to finalizing your installation plans.

### ENGINE GENERATOR SET MOUNTING

#### **WARNING - Personal Injury**

***The enclosures on these units can become very hot adjacent to the exhaust areas. Special care must be taken when installing these units to insure that the risk of contact by people is minimized.***

The unit's main frame should be bolted solid to a four to six inch thick cement pad. The engine-generator is mounted on a sub-frame which is isolated with special shock mounts on the main frame. This allows the engine-generator to vibrate without affecting the control panel on the main frame.

Do not install any shock mounts between the base frame and the concrete pad. Engine vibration will be transmitted to the control panel causing erroneous start/stop cycles and premature control failure.

The unit should be mounted to allow for ample working room around it. A general rule to follow is five (5) feet clearance on all sides. See NFPA Code 37 for additional clearance requirements.

## FUEL INSTALLATION

The fuel supply should be as close as possible to the engine. This will reduce the installation cost of fuel runs. The information in this manual is offered to assist you in providing the proper fuel for your engine. However, this information is only provided to inform you of the engine's requirements and assist in making you aware of the decisions you must make. In no case should the instructions or information provided be interpreted to conflict with any local, state or national codes. If in doubt, always consult your local fire marshal or gas supplier.

\*\*\*\*\*  
**\*\*\*\*\* WARNING \*\*\*\*\***  
 \*\*\*\*\*

**FIRE HAZARD** - All fuel runs should be installed by a licensed fuel supplier.

To connect the fuel line to the generator set you will have to remove the access panel on the air intake end of the enclosure. With this panel removed you will be able to access the complete fuel system on the unit. You will need to do two things with this panel removed.

First you will connect your incoming fuel line to the 3/4 inch NPT fitting provided inside the enclosure. This is shipped with a plastic cap plug installed to insure the fuel system stays clean.

For all vapor fuel systems the delivery pressure of the fuel to the fuel solenoid on the unit must be four to six ounces psi (per square inch) or 7 to 11 inches W.C. (Water column). These fuel pressures are critical; failure to provide the proper fuel pressure can cause many problems ranging from a unit that will not start to causing damage to the fuel system.

The second thing you need to do is ensure that your unit is connected for the correct fuel. These units come capably of working on either LP or NG fuel. It just depends on where the fuel line from the engine is connected to the demand regulator.

These units are normally tested on Natural gas and will have the fuel line connected to the N.G. port on the fuel outlet tee. If you are going to operate on LPG you will need to move the fuel line from the NG port to the LPG port on the fuel outlet tee. These two ports have different orifice inserts installed in them, which provide proper engine operation with no further adjustments.

When moving the fuel line from one port to the other be sure not to kink or bend the line. Use as large a sweeping curve as possible and never shorten the fuel line. For proper operation the fuel line must stay the same length as it was shipped.

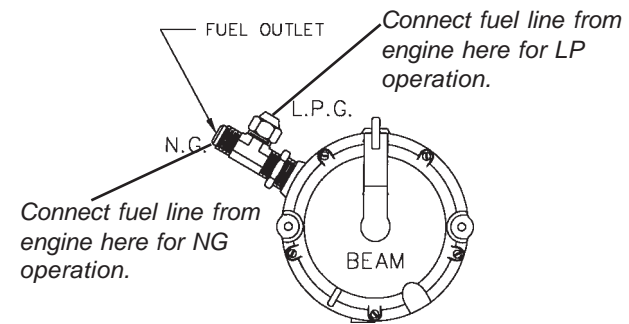

## INSTALLING THE FUEL LINE

### \*\* NOTICE \*\*

*The engine generator sets are properly adjusted before they leave the factory. A tag is attached to the unit that specifies the fuel, natural gas (NG) or propane vapor (LP) that the unit was set up and tested on.*

### Line Size

Unit location will determine the size of fuel line that is required to supply the engine with a constant fuel pressure and volume. Refer to the tables below for fuel line size, fuel consumption and recommended tank size. For distances of 50 feet and over, a two regulator fuel system is recommended. This is accomplished by installing a primary regulator at the tank which will reduce the tank pressure down to 10 to 15 lbs. A secondary regulator is installed to further reduce the fuel pressure to the required four (4) to six (6) oz operating pressure. This secondary regulator must be at least 10 feet from the engine generator set, any closer installation will require a larger line be installed to provide a fuel reservoir. This is also true for the single dual stage regulators, it should also be minimum of 10 feet from the unit. If this is not done the demand regulator on the unit and the pressure regulator in the fuel line will interfere with each other.

When the two (2) stage regulator system is used, a fuel line size of 1/2 to 5/8 inch is generally adequate for distances up to 300 feet from the primary to the secondary regulator. (Consult your local fuel supplier for your exact requirements.) The appropriate line size from the table below is then installed from the secondary regulator to the generator set.

\*\*\*\*\*  
**\*\*\*\*\* WARNING \*\*\*\*\***  
 \*\*\*\*\*

**PERSONAL DANGER** - Do not use galvanized pipe in fuel line runs. The galvanized coating can become eroded and flake off, causing possible obstructions in the regulator or fuel valve. The results could range from inoperative engine start to hazardous fuel leaks.



## NATURAL GAS or LP VAPOR

Size of pipe normally required for generators operating on **NATURAL GAS or LP VAPOR**

up to 25 feet\* 25 - 100 feet\* over 100 feet\*

PSS12H 3/4" pipe 1" pipe use a two regulator system  
 \*Allow an additional 3 feet for each standard elbow. Do not use 'street ells' (restrictive)\*

### \*\*\*\* CAUTION \*\*\*\*

*Be careful when sealing gas joints. Excessive sealing compound can be drawn into the solenoid, regulator or carburetor causing an engine malfunction.*

## FUEL PRESSURE

### L.P. & N.G. VAPOR FUEL

Correct fuel pressure cannot be stressed enough. The most common cause for inoperative systems is an inadequate or incorrect fuel pressure. Performance of the engine is in direct relation to the correctness of the fuel system. Shown below is a block diagram of a typical L.P. or N.G. vapor fuel installation.

Notice the following tables give two (2) different units of measuring fuel pressure. The first and most accurate is the use of a simple water manometer. A manometer is calibrated in inches of water column. The second is with a pressure gauge calibrated in ounces per square inch.

### TWO REGULATOR FUEL SYSTEM

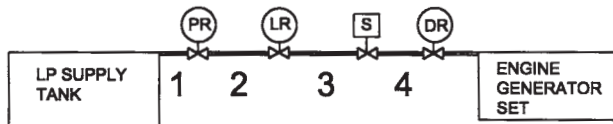

LEGEND  
 PR - PRIMARY REGULATOR  
 (REDUCES TANK PRESSURE TO 10-15 PSI)  
 LR - LOW PRESSURE REGULATOR  
 (REDUCES FUEL PRESSURE TO 4 TO 6 OZ)  
 S - FUEL SOLENOID VALVE  
 (POSITIVE FUEL SHUT-OFF SOLENOID)  
 DR - DEMAND REGULATOR  
 (REQUIRES ENGINE VACUUM TO OPEN)

### DUAL STAGE SINGLE REGULATOR SYSTEM

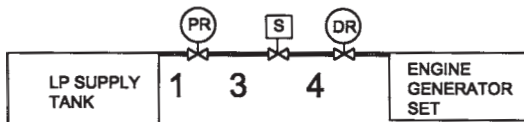

LEGEND  
 PR - PRIMARY REGULATOR  
 (REDUCES TANK PRESSURE TO 4 TO 6 OZ)  
 S - FUEL SOLENOID VALVE  
 (POSITIVE FUEL SHUT-OFF SOLENOID)  
 DR - DEMAND REGULATOR  
 (REQUIRES ENGINE VACUUM TO OPEN)

Reference numbers 1 through 3 in the block diagrams above are system parts supplied by customer.

Reference number 4 is the engine generator set.

Below is a table of the fuel pressure reading at each reference in the system.

### Fuel Pressure Table

#### Single Regulator (L.P. Vapor only)

	1	3	4
UNIT OFF	TANK PSI	7-11 in 4-6 oz	7-11 in 4-6 oz
STARTING	TANK PSI	7-11 in 4-6 oz	7-11 in 4-6 oz
NO LOAD	TANK PSI	7-11 in 4-6 oz	7-11 in 4-6 oz
FULL LOAD	TANK PSI	7-11 in 4-6 oz	7-11 in 4-6 oz

#### Two (2) Regulator System (L.P. Vapor only)

	1	2	3	4
UNIT OFF	TANK PSI	10-15 lbs 4-6 oz	7-11 in 4-6 oz	7-11 in 4-6 oz
STARTING	TANK PSI	10-15 lbs 4-6 oz	7-11 in 4-6 oz	7-11 in 4-6 oz
NO LOAD	TANK PSI	10-15 lbs 4-6 oz	7-11 in 4-6 oz	7-11 in 4-6 oz
FULL LOAD	TANK PSI	10-15 lbs 4-6 oz	7-11 in 4-6 oz	7-11 in 4-6 oz

#### Natural Gas

	1	3	4
UNIT OFF	LINE PSI	7-11 in 4-6 oz	7-11 in 4-6 oz
STARTING	LINE PSI	7-11 in 4-6 oz	7-11 in 4-6 oz
NO LOAD	LINE PSI	7-11 in 4-6 oz	7-11 in 4-6 oz
FULL LOAD	LINE PSI	7-11 in 4-6 oz	7-11 in 4-6 oz

### LP/NG FUEL CONVERSION

The PSS12H2W/A generator systems have been tested on **NATURAL GAS** prior to shipment. If you are going to use them on **LP vapor**, follow the procedures outline in fuel installation.

### LUBRICATION

Before starting the engine, check and fill the crankcase with the proper weight/grade of oil, as recommended by the engine manufacturer's maintenance instructions. The necessity of using the correct oil, and keeping the crankcase full cannot be over emphasized. **Do Not Overfill the Engine, Use the Dipstick.**

## INSTALLING THE BATTERY

### \*\*\*\* CAUTION \*\*\*\*

*In the following battery installation procedure, check to be sure the selector switch remains in the "stop" position. This should be your last step before initial start-up.*

A customer supplied twelve-volt battery is required to complete the installation. Installation of the highest CCA rated battery, within the correct BCI group, will increase cold weather starting performance. *Gel batteries should not be used* with the battery tender installed in the generator enclosure.

<b>Model</b>	<b>Voltage</b>	<b>BCI Group</b>	<b>MINIMUM CCA Rating</b>
<b>PSS12H</b>	12	26	500

Installation and servicing of batteries must be performed or supervised only by personnel knowledgeable of batteries and the required precautions. Keep unauthorized personnel away from batteries.

When installing or replacing batteries, use the proper group/size **starting** battery. The battery should be a Maintenance Free lead acid design. Deep cycle batteries will not work for this application.

### CAUTION – PERSONAL DANGER

**CAUTION - NEVER** dispose of a battery in a fire. The battery is capable of exploding.

**CAUTION - DO NOT** open or mutilate the battery. Released electrolyte is known to be harmful to the skin and eyes and to be very toxic.

These engine generator sets are all **NEGATIVE** ground. Be very careful not to connect the battery in reverse polarity, as this may short circuit the battery charging system on the engine.

**CAUTION** – A battery presents a risk of electrical shock and high short circuit current. The following precautions must be observed when working with batteries.

1. Remove watches, rings and other metal objects.
2. Use tools with insulated handles.
3. Check both the battery cable ends and the battery posts to be sure they are free of corrosion.
3. Always connect the battery positive cable first and then connect the battery negative cable. When removing the battery cables from the battery reverse the procedure, disconnect the negative cable first and then the positive cable.
4. Be sure all connections are tight and coat the terminals and cable end with dielectric grease.

**WARNING** – The electrolyte is a diluted sulfuric acid that is harmful to the skin and eyes. It is electrically conductive and corrosive. The following precautions must always be taken.

- \* Always wear full eye protection and protective clothing.
- \* Where electrolyte contacts the skin, wash off immediately with water.
- \* If electrolyte contacts the eyes, flush thoroughly and immediately with water and seek immediate medical attention.
- \* Spilled electrolyte is to be washed down with an acid neutralizing agent. A common practice is to use a solution of one pound of bicarbonate of soda (baking soda) to one gallon of water. The bicarbonate of soda solution is to be added until the evidence of reaction, foaming, has ceased. The resulting liquid is to be flushed with water and the area dried.

### DANGER – Explosive Fire Risk

- \* Never smoke when near batteries
- \* Do not cause a flame or spark in the battery area
- \* Always discharge static electricity from your body before touching batteries by first touching a grounded metal surface.

### SERVICING BATTERIES

Batteries used on these units may over time lose water. This is especially true if you are using a trickle charger to maintain your battery. When refilling the battery with water use only distilled water. Tap water will shorten the service life of the battery.

Never fill the battery above the fill line. Over filling above the upper level line may cause the electrolyte to overflow, resulting in corrosion to the engine or nearby parts. Immediately wash off any spilled electrolyte following the procedure above..

### BATTERY CHARGING

Units equipped with electric start have a small flywheel charger built into the engine flywheel assembly for recharging the starting battery. This flywheel charger generates a small AC current that passes through a rectifier/regulator assembly on the engine to produce a DC charging current. This circuit is not designed to be used as a battery charging circuit to recharge dead batteries.

### \*\*\*\*\*CAUTION\*\*\*\*\*

**EQUIPMENT DAMAGE** - *Always connect the positive cable first and the negative cable last, when disconnecting, it is negative cable first and positive last. Failure to connect and disconnect in the proper sequence can cause equipment damage.*

Observe polarities: connect the positive (+) battery terminal to the (+) cable from the control panel; the negative (-) battery terminal is connected to the negative cable (ground) from the engine generator assembly. All connections must be clean and tight. Check the electrolyte (fluid) in the battery periodically to be sure it is above the plates. Never allow the battery to remain in a discharged condition.



\*\*\*\*\*CAUTION\*\*\*\*\*

**EQUIPMENT DAMAGE - NEVER JUMP START** these units. Doing so will destroy the engine control module rendering the unit non-operational. Remove and fully recharge the battery before attempting to start.

### CONNECTING THE BATTERY CHARGER

A two-stage battery tender is provided on all PSS series generators. This battery tender charges at a rate of 750 mA until the battery is fully charged and then automatically switches to a 13.2 VDC float charger. The charger has an indicator light on it, red indicates it is charging, and green indicates it is in the storage mode (float charge). This charger is mounted on the engine generator set in the same location as the other AC and DC connections.

The battery tender receptacle is to be powered by a GFCI circuit and installed in accordance with the United States National Electric Code. These AC wires can be run in the same conduit as the other AC leads from the generator. It is suggested that this circuit be fused for 15 amps. Terminal block connections have been provided in the customer connection area of the engine generator set. See Page 8 for diagram.

**\*\* NOTICE \*\***

*The battery tender is not intended to recharge a battery which has become completely discharged. It is designed to produce enough current to recharge a slightly low battery, maintaining it fully charged.*

### MOUNTING THE AUTOMATIC TRANSFER SWITCH (A.T.S.)

\*\*\*\*\*  
\*\*\*\*\* **WARNING** \*\*\*\*\*  
\*\*\*\*\*

**EQUIPMENT DAMAGE-** Protect the switch from construction grit and metal chips to prevent a malfunction or shortened life of the switch. Contactors returned for warranty consideration with foreign material inside of them will not be warranted.

The Automatic Transfer Switch connects the load (lights, furnace, outlets, etc.) to the normal power line during standby. When normal power fails, the A.T.S. starts the engine generator set, disconnects the power line and then connects the load to the standby generator set. When normal power is restored, the automatic switch retransfers the electrical load to the normal service and stops the engine. The A.T.S. panel should be mounted as close to the distribution panel as possible.

\*\*\*\*\*  
\*\*\*\*\* **WARNING** \*\*\*\*\*  
\*\*\*\*\*

*All wiring must be done by a licensed electrician, and must conform to the national electrical code and comply with all state and local codes and regulations. Check with your electrical inspectors before proceeding!*

Before installing the A.T.S. you must first ensure that the transfer switch is large enough to handle your complete distribution panel. See Figure 3. i.e. If you are installing a 100 amp transfer switch the main line breaker must not be larger than 100 Amps. If you have a 125, 150 , 200 Amp or larger system and want to use a 100 amp transfer switch, you will not be able to transfer the complete electrical system. In this case it will be necessary to install a secondary emergency distribution panel. See Figure 4. NOTE: THE MAXIMUM OUTPUT OF THE GENERATOR IS 50 AMPS AT 240 VOLTS. You must also take this into consideration when deciding whether to install an emergency distribution panel.

## A.C. ELECTRICAL CONNECTIONS

**NOTICE - CLASS 1 WIRING METHODS ARE TO BE USED FOR ALL FIELD WIRING CONNECTIONS TO TERMINALS OF A CLASS 2 CIRCUIT**

\*\*\*\*\*  
\*\*\*\*\* **WARNING** \*\*\*\*\*  
\*\*\*\*\*

*A main line circuit breaker has been provided inside the generator housing. During all wiring installation make sure the breaker is in the off position and the generator operation switch is in the off position.*

**Note:** This symbol  always indicates ground where used.

### Generator Connections

Minimum Conductor Sizes between the Generator and the ATS. Based on wire type and temperature rating. Wire has been derated for 40° C ambient temperatures.

C/B kW Amp	CU Conductor		AL Conductor	
	Wire Temperature Rating			
	75°C	90°C	75°C	90°C
12 50	#6 AWG	#8 AWG	#4 AWG	#6 AWG

To gain access to the customer connections remove the end panel opposite the hot air discharge end. All connections including AC & DC connections to the ATS, 120 Volt power connection for battery charger, and battery installation are made behind this panel. After removing the end panel you will need to remove the cover over the connection box in the upper right hand corner. Knockouts are provided on the outside of the enclosure for your convenience. See page 16 for unit layout.

Four AC power leads are required between the generator and the A.T.S.; Two hot leads, a neutral and a ground lead. You will then need to run both a neutral and a ground lead in addition to the two power leads all the way back to your distribution panel. The two power leads from the generator are marked G1 and G3.

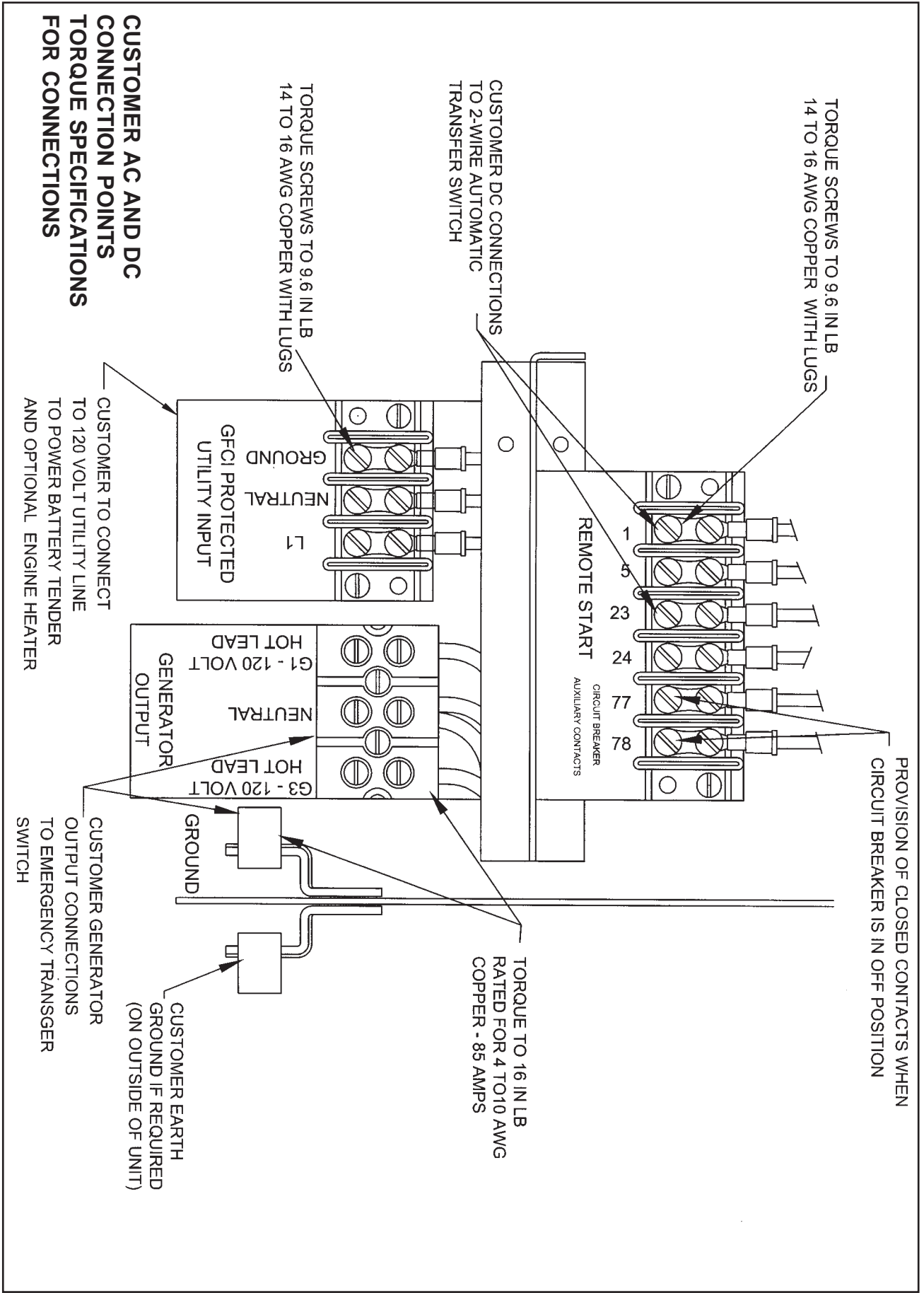

In addition to the power leads you will also need to run a three wire 120 volt, 15 amp circuit from your distribution panel to the generator. This circuit will be used to power the battery charger.

The last two wires you will need are the DC control leads (14 or 16 gauge) for the start circuit in the A.T.S. These last two connections will be discussed later in more detail.

## WINCO UL ATS (ASCO165)

**See the ASCO installation manual for additional details on proper wiring of the Automatic Transfer Switch.**

The standby generator terminals in the A.T.S are marked "ALTERNATE L2 & L6". The "hot" leads G1 and G3 from the generator are connected to the terminals L2 & L6.

The normal line power terminals in the A.T.S. are marked "PREFERRED - L1 & L5". The "hot" line power leads are L1 and L3 from your normal power supply are connected to terminals L1 and L5.

The load terminals in the A.T.S. are marked "LOAD - L3 & L7". The leads to the load distribution panel are connect to terminals L3 & L7.

The neutral leads from all three locations are connected to the isolated terminal lugs on the sidewall of the cabinet. This terminal block is labeled "NEUTRAL" and the terminal lugs are mounted on red isolation standoffs.

The ground leads from all locations are connected to the grounded terminal lugs, also on the side wall. This set of terminals is labeled "GROUND".

## INSTALLATION NOTES

The load current carrying wires (L) and (T) must be sized to handle the maximum load current without excessive voltage drop. By code, the wire must be heavy enough to handle the full current rating of the main line circuit-breaker (or fuse) in the entrance (or sub-panel) protecting the contactor switch.

All wires should be installed in rigid or flexible conduit. (Knockouts are provided in the control box)

Because of the many different types of service, feeder, and distribution equipment, no specific wiring instructions can be provided. It is, however, recommended that only copper wire be used. In all cases it is essential that while the load is connected to the generator, there can be absolutely no feedback from the generator to the power line or the power line to the generator. When properly installed, the normal A.T.S. control and safety systems will eliminate all paths for feedback. Check with your local electrical inspector on applicable local, state and federal codes.

\*\*\*\*\*  
\*\*\*\* **WARNING** \*\*\*\*  
\*\*\*\*\*

*A service disconnect must be installed in front of the A.T.S. panel as the A.T.S is not service entrance rated.*

*This will allow you to test the generator under load. Should you ever have to work on the switch, you will be able to disconnect the power and work on the switch cold without having the power company pull your meter.*

To wire the automatic transfer switch into the existing wiring, first determine which circuits will be on the emergency load circuit. If the entire load is to be transferred, the transfer switch can be wired in directly after the watt-hour meter and the service entrance, providing the service entrance ampere rating is within the transfer switch's rated capability.

If only specific circuits are to be powered under emergency power failure conditions, an additional distribution panel designated "emergency distribution panel" must be installed.

All selected emergency circuits are removed from main distribution panels and reinstalled in the emergency distribution panel. Suggested circuits: freezer, refrigerator, furnace, emergency lights, sump pump, emergency outlet circuits, etc. Total running load must not exceed generator rating.

## D.C. ELECTRICAL INTERCONNECTION

\*\*\*\*\***CAUTION**\*\*\*\*\*

*Never run the AC and DC wiring in the same conduit.*

## ASCO 165 UL SWITCH

Your DC connection points in the ASCO 165 UL ATS are on the terminal block in the upper right hand corner of the ATS panel. The terminal block is numbered 1 through 9. You will be using terminals 4 and 5, wire Start 23 will connect to terminal #5 and wire Start 1 will connect to terminal #4. See page 15 for a connection diagram.

# INITIAL START UP

\*\*\*\*\*

\*\*\*\*\* **WARNING** \*\*\*\*\*  
\*\*\*\*\*

*DO NOT jump start these engine generator sets. Starting these units on a low battery or jump starting them will cause damage to the engine control module.*

**Use the following checklist to verify correct installation before starting the engine:**

- Engine oil.\* Check level & fill as required with proper grade/qty.
- Unit mounting base properly bolted down.
- Clearance for service and maintenance on all sides.
- Proper fuel line material and size.
- All fuel line connections tight.
- Fuel line protected and a moisture trap installed (may be required for N.G.).
- LP/NG pressure O.K. 4-6 Oz. (7-11" WC).
- Battery connections clean and tight.
- Battery fully charged.
- All A.C. and D.C. wiring installed and properly protected.

\* Refer to engine owners manual for proper levels and type.

After completing the above checklist, the engine generator set is ready for the initial start-up test.

## PROCEDURE

Move the selector switch on the engine generator to the "RUN" position. The engine generator will crank and start automatically. If the engine fails to start, return selector switch to the "stop" position and correct the trouble before proceeding.

With the engine running smoothly, check the no load voltage and frequency at terminals L2 and L6 in the ASCO ATS on the generator terminal block in the ATS. The voltage should be between 242 to 248 volts. The frequency should be between 61.5 to 62 hertz (Hz). The voltage should also be checked between the hot terminals (L2 and L6) and the neutral to be certain of a balanced voltage output and a solid neutral connection. The voltage should be about one half of the line to line voltage or approximately 121 to 124 volts AC between both power feeds and neutral.

**\*\* Notice \*\***

*If for any reason during the check out procedure the voltage and frequency are not correct, turn the selector switch to the "STOP" position and correct the trouble before proceeding.*

After verifying the voltage and frequency are correct, turn the selector switch to the "STOP" position. The unit should shut off with no time delay. You are now ready to test the automatic start function.

## Transfer Switch & Engine Generator

This procedure checks the electrical operation of the automatic transfer switch. If the actual operation does not follow this procedure, consult the troubleshooting section in the transfer switch manual.

If you are not using the ASCO165 transfer switch you will need to follow the information in the manual for your ATS for initial starting and testing procedure. This procedure will also test the interface between the transfer switch and the engine generator set.

\*\*\*\*\*

\*\*\*\*\* **WARNING** \*\*\*\*\*  
\*\*\*\*\*

**PERSONAL INJURY HAZARD** - *Install front cover on to transfer switch before operation. An electrical system fault could cause a flash and severe personal injury.*

1. Turn on the preferred source (utility) circuit breaker. The utility source acceptable light should now come on as well as the transfer switch on utility light. If these lights fail to come on recheck your incoming power to insure you have 240 volts nominal. If not, troubleshoot your utility source before continuing.
2. Move the toggle switch in the generator from the stop position to the auto position. The unit is now ready to be operated from the Automatic Transfer Switch.
3. Turn on the alternate source (generator) circuit breaker.
4. Press and hold the **Push to Test** button until the generator (alternate source) acceptable light comes on and stays on. Then release the button. This will start up your generator set.

This light indicates that the generator is running and the output voltage and frequency are within acceptable limits. Under normal conditions this light should come on in 5 to 10 seconds. If the light does not come on and stay on a malfunction has occurred. Either the unit didn't start or the voltage or frequency is incorrect. Correct the problem before continuing.

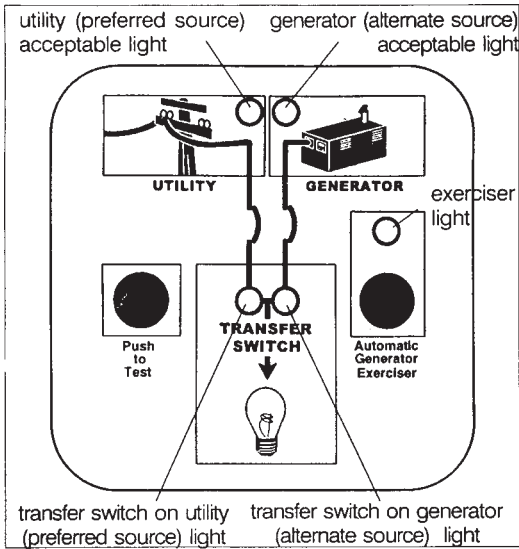

5. About 15 seconds after the generator (alternate source) acceptable light comes on, the automatic transfer switch should transfer the load from the utility to the generator. At that time the **Transfer Switch** on generator light should come on.
6. The generator will stay connected to the load for about 5 minutes at which time the transfer switch will transfer the load back to the utility. At the time it transfers back to utility the Transfer Switch on Utility light should come on and the Transfer Switch on generator light should go out. To bypass this five minute time delay you can press and release the Push to Test button again at any time.
7. After the load retransfers to the utility the generator will continue to run for about 1 minute (without a load) and then shut down. The Generator acceptable light will go off indicating the generator set has shut down.

Once you are finished testing the transfer switch, this completes your installation and unit testing. ALWAYS leave the system in automatic mode unless servicing the unit. For automatic operation, keep the generator set mode switch in the "AUTOMATIC" position.

## GENERATOR EXERCISER CIRCUIT

The automatic generator exerciser is configured to automatically exercise the generator for 20 minutes once every fourteen days .

### SETTING THE EXERCISER CIRCUIT

Press and release the **Automatic Generator Exerciser** button. After about 8 seconds the exerciser light flashes 14 times to indicate that the exerciser circuit has been set. The number of flashes indicates the number of days until the next exercise period. This 20 minute period will occur at approximately the same time of the day the button was pressed.

### DISABLING THE EXERCISER CIRCUIT

Press and hold the **Automatic Generator Exerciser** button until the light above the button goes off, the light flashes and then goes off.

### ENABLING THE EXERCISER CIRCUIT

Press and hold the **Automatic Generator Exerciser** button until the light goes off, the light flashes then goes off. After about 8 seconds the exerciser light flashes fourteen times to indicate that the exerciser circuit has been re-enabled.

\*\*\*\*\*  
 \*\*\*\*\*  
 \*\*\*\*\* **WARNING** \*\*\*\*\*  
 \*\*\*\*\*

***WITH A TOTAL POWER FAILURE (UTILITY POWER FAILS AND THE GENERATOR FAILS TO START AND RUN) THE EXERCISER MUST BE RESET AFTER THE POWER IS RESTORED.***

Once you are finished testing the transfer switch, this completes your installation and unit testing. ALWAYS leave the system in automatic mode unless servicing the unit. For automatic operation, keep both the generator set and transfer selector switches in the "AUTOMATIC" position.



# TROUBLESHOOTING TABLES

## RED ALARM LIGHT IS ON

The red alarm light on the engine control panel is an indication that the unit either failed to start during the last cycle or shut down before the cycle or outage was complete. Moving the toggle switch on the engine control to the off position will turn the light off and allow the engine to be restarted.

\*\*\*\*\*

\*\*\*\*\* **WARNING** \*\*\*\*\*  
\*\*\*\*\*

*A light alarm light means the unit either when into overcrank, the engine is low on oil or the engine stopped for some reason. Before resetting the light and operating the unit first determine why it shut down. Failure to correct a problem could cause permanent damage to you equipment.*

\*\*\*\*\*

\*\*\*\*\* **WARNING** \*\*\*\*\*  
\*\*\*\*\*

**NEVER JUMP START THESE UNITS. JUMP STARTING THESE UNITS WITH LOW OR BAD BATTERIES WILL CAUSE PERMANENT DAMAGE TO THE ENGINE CONTROL MODULE.**

## UNIT WILL NOT CRANK WHEN THE POWER FAILS.

1. Alarm light on, from previous run cycle.
2. Generator control switch not in "AUTOMATIC" position.
3. Transfer switch control board not closing the run contacts.
4. Low or dead battery, must hold 12 volts during cranking.
5. Incorrect wiring between transfer switch and generator.
6. Defective engine control module.
7. Circuit breaker tripped on engine control.
8. 3/4 amp fuse blown on engine control.
9. Loose or dirty battery terminals.
10. Defective "Run/Auto" switch.
11. Defective starter.
12. Defective start solenoid.

## ENGINE WILL NOT CRANK WITH GENERATOR SELECTOR SWITCH IN THE RUN POSITION.

1. Low or dead battery, must hold 12 volts during cranking.

2. DC circuit breaker on control module tripped.
3. 3/4 amp fuse blown on control module.
4. Defective engine controller.
5. Loose or dirty battery terminals.
6. Defective "Run/Auto" switch.
7. Defective starter.
8. Defective start solenoid.
9. Locked up engine generator set.

## ENGINE CRANKS BUT WILL NOT START.

1. Improper fuel pressure being delivered to unit.
2. Fuel supply shut off.
3. Fuel tank empty.
4. Defective spark plug.
5. Defective engine ignition module.
6. Dirty air cleaner filter.
7. Defective fuel solenoid valve.
8. Low voltage from battery to fuel solenoid, must hold 12 volts during cranking.
9. Oil in the bottom of air cleaner from crankcase breather.

## ENGINE STARTS AND THEN STOPS AND FAULT LIGHT COMES ON.

1. Engine is low on oil.
2. No AC output from generator to engage stop crank circuit.

## ENGINE WILL NOT COME UP TO SPEED AFTER IT STARTS.

1. Insufficient fuel volume getting to the unit.
  - a. Fuel line too small.
  - b. Low fuel pressure.
2. AC short circuit.
3. Wiring to the A.T.S. panel crossed or shorted.
4. Unit is overloaded, check load amperage.

## ATS PANEL WILL NOT TRANSFER TO EMERGENCY SUPPLY (GENERATOR).

1. No AC generator output from generator.
2. See Automatic Transfer Switch Manual

## ATS PANEL WILL NOT PULL IN ON NORMAL POWER.

See Automatic Transfer Switch Manual

## NO AC OUTPUT FROM GENERATOR.

1. Diodes on rotor blown.
2. Defective capacitor(s).
3. Defective rotor.
4. Defective stator.
5. AC short in the output leads.
6. Unit has lost its residual voltage.
7. Rotor loose on engine crankshaft.
8. Low engine speed, must be 3600 RPM.
9. AC short on output leads.

# PREVENTIVE MAINTENANCE

Reasonable care in preventive maintenance will insure high reliability and a long life for the engine generator set and the Automatic Transfer Switch.

\*\*\*\*\*  
\*\*\*\* WARNING \*\*\*\*  
\*\*\*\*\*

*When performing any type of maintenance on this equipment make sure the selector switch on the engine generator is in the off position. If you are working in the Automatic Transfer Switch, confirm with a reliable meter that all power has been disconnected.*

## **AUTOMATIC TRANSFER SWITCH**

Clean and inspect the switch once a year. De-energize all power sources, both line and engine generator set, then brush and vacuum away any excessive dust and dirty accumulation. You can at this time with the contactor de-energized remove the contactor covers and check the contacts. Make sure the contacts are clean and not burned or pitted.

## **ENGINE GENERATOR SET**

Service the engine in accordance with the engine manufacturers manual provided with your new equipment. Routinely remove debris and dirt from around and inside generator enclosure. Insure that the air intakes are free from leaves and other debris at all times.

Clean and inspect battery terminals at least twice a year. Check the battery water level at least twice a year also.

Other than keeping the generator clean and free of debris there is no other routine or preventive maintenance required, as long as the generator is run biweekly to keep it dry and in good working order.

# AC AND DC GENERATOR SCHEMATIC

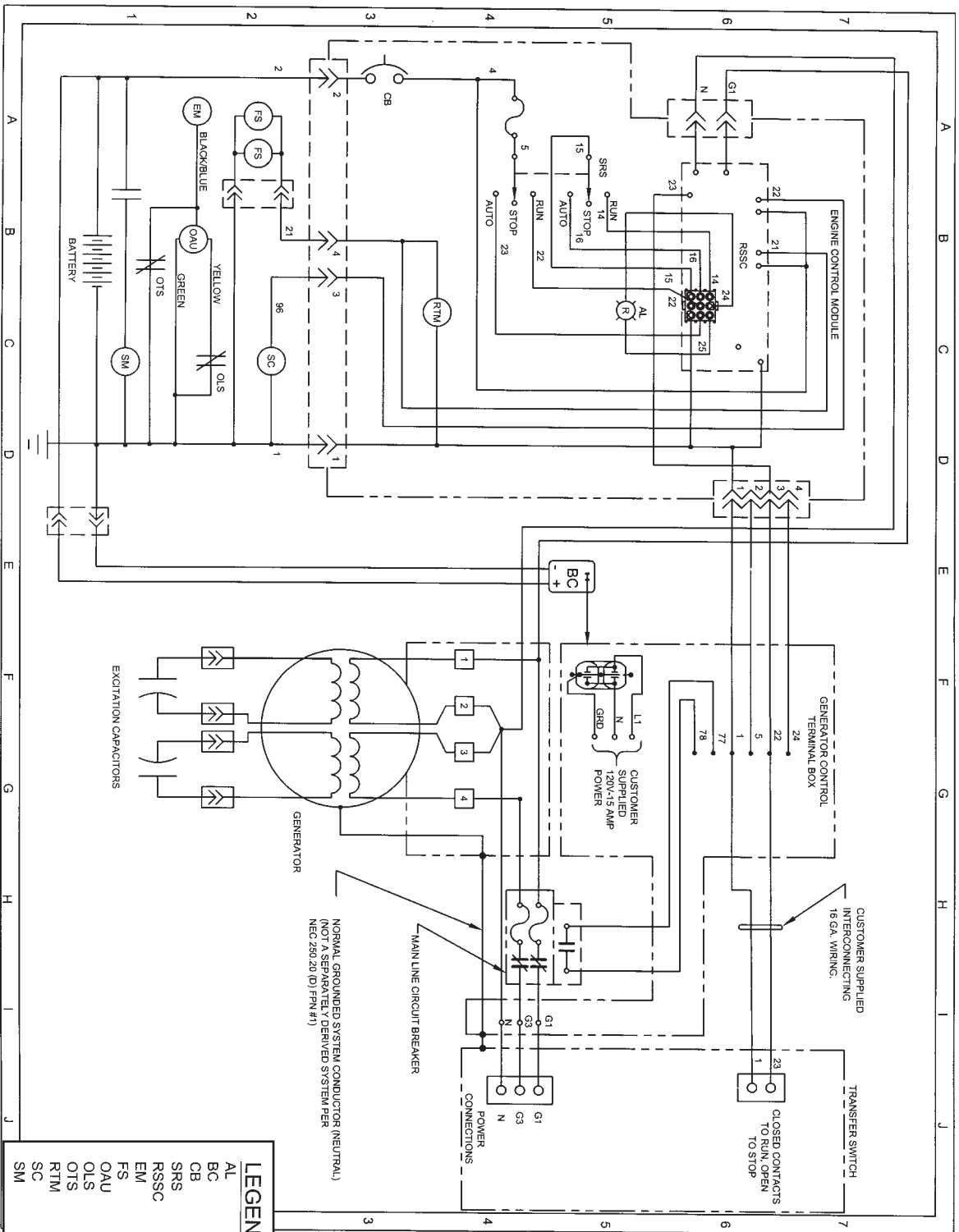

LEGEND	
AL	ALARM LAMP (SYSTEM FAILED)
BC	BATTERY CHARGER
CB	CIRCUIT BREAKER
SRS	RUN/STOP/AUTO SWITCH
RSSC	ENGINE CONTROL MODULE
EM	ENGINE MAGNETO
FS	FUEL SOLENOID
OAU	OIL ALERT UNIT
OLS	OIL LEVEL SWITCH
OTS	HIGH OIL TEMP SWITCH
RTM	RUNNING TIME METER
SC	START CONTACTOR
SM	STARTER MOTOR

# WINCO UL ATS

Complete installation instructions for WINCO UL Automatic Transfer Switches are contained in the operator manual with each switch. Read the complete instructions before installing.

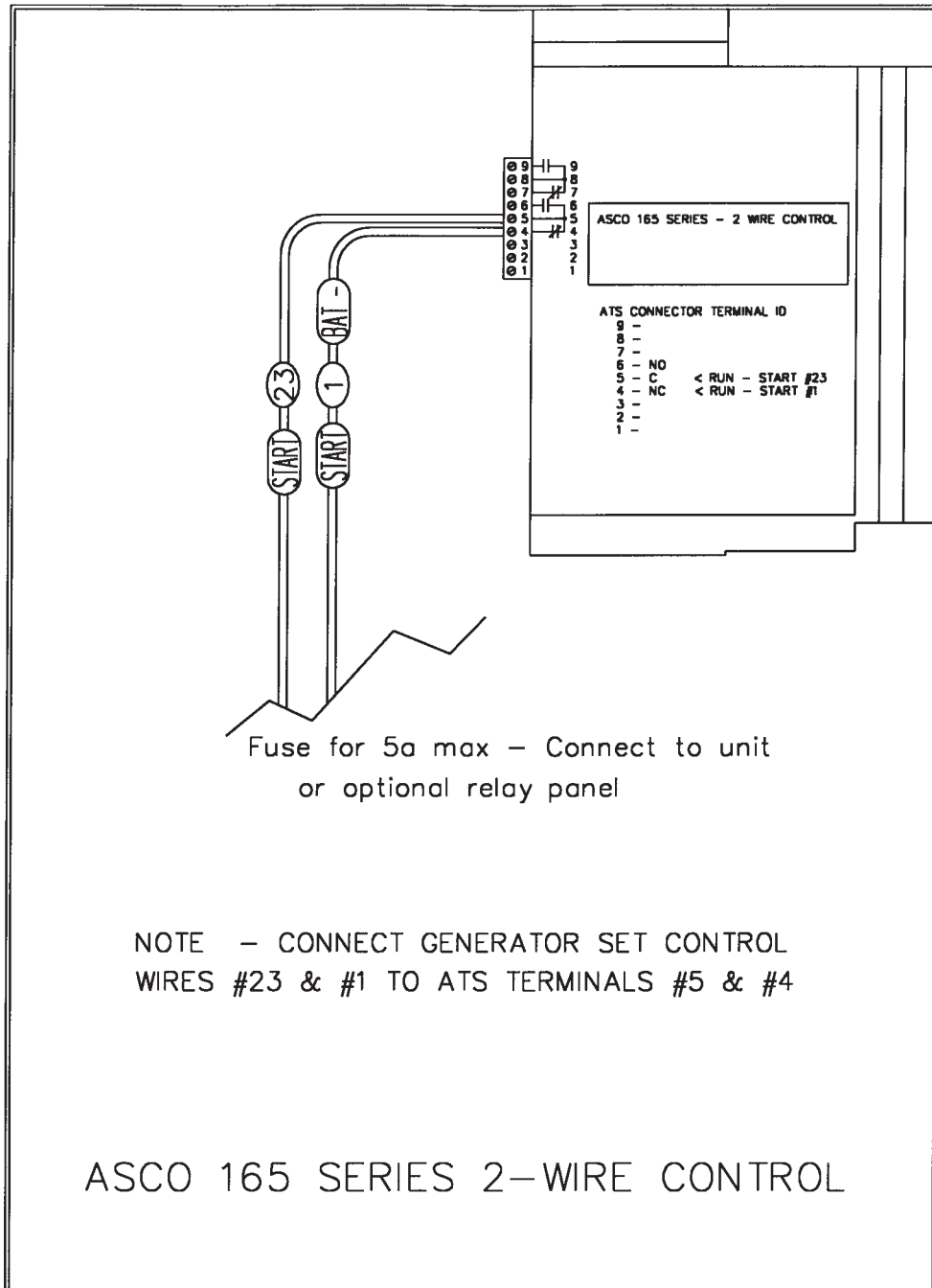

### CUSTOMER DC CONNECTION POINT

All control wires (18-12 AWG) must be torqued to 19 in-lbs.

# GENERATOR LAYOUT PSS12H2W

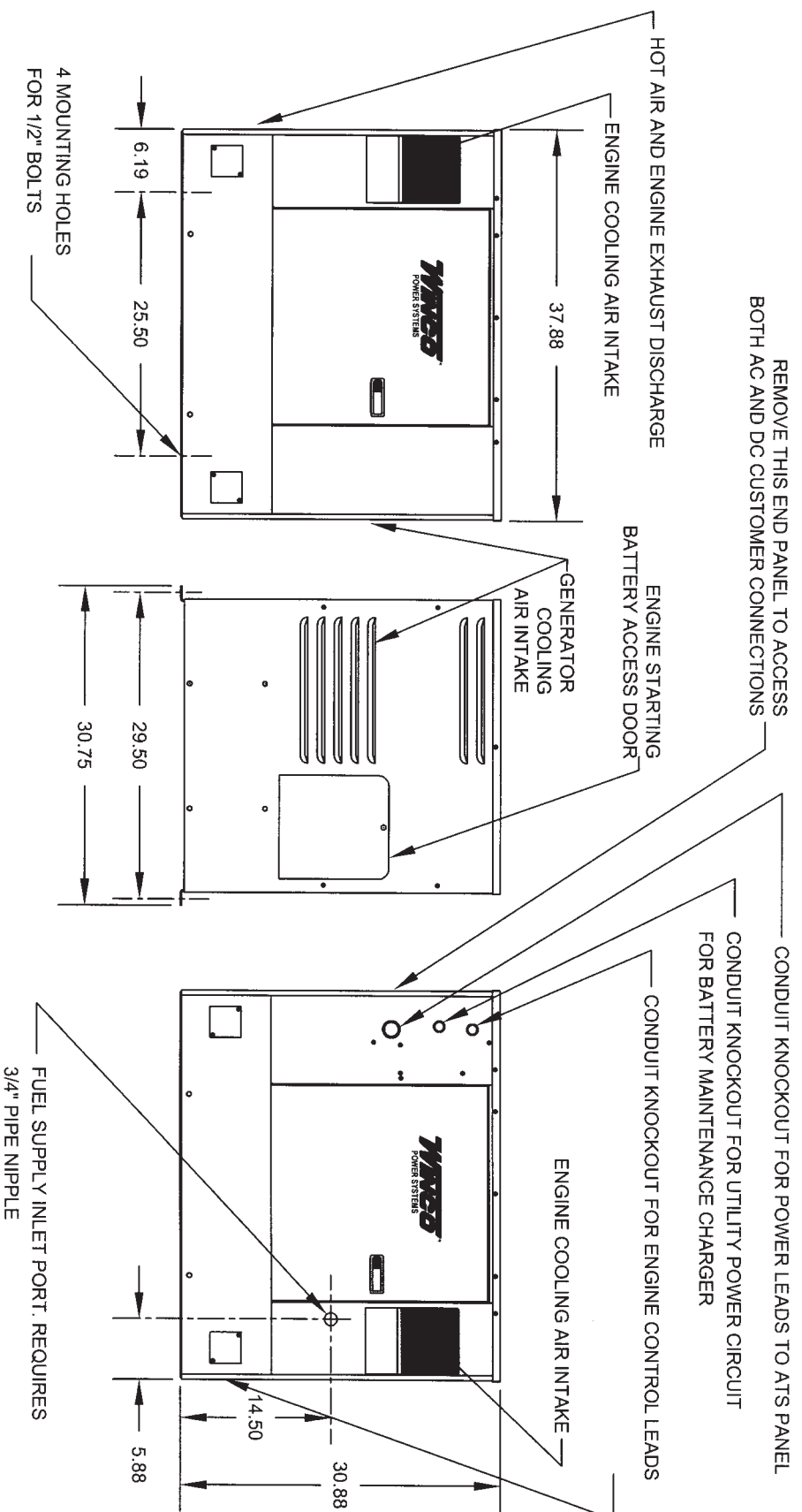



# **WINCO<sup>®</sup> INC**

*A Division of **DTE** Dyna Technology Inc*

## **12 MONTH LIMITED WARRANTY**

WINCO, Incorporated warrants to the original purchaser for 12 months or 1000 hours which ever occurs first, that goods manufactured or supplied by it will be free from defects in workmanship and material, provided such goods are installed, operated and maintained in accordance with WINCO written instructions.

WINCO's sole liability, and Purchaser's sole remedy for a failure under this warranty, shall be limited to the repair of the product. At WINCO's option, material found to be defective in material or workmanship under normal use and service will be repaired or replaced. For warranty service, return the product within 12 months or 1000 hours which ever occurs first from the date of purchase, transportation charges prepaid, to your nearest WINCO Authorized Service Center or to WINCO, Inc. at Le Center Minnesota.

**THERE IS NO OTHER EXPRESS WARRANTY.**

To the extent permitted by law, any and all warranties, including those of merchantability and fitness for a particular purpose, are limited to 12 months or 1000 hours which ever occurs first, from date of purchase. In no event is WINCO liable for incidental or consequential damages.

Note: Some states do not allow limitation on the duration of implied warranty and some states do not allow the exclusion or limitation of incidental or consequential damages, so the above limitations may not apply in every instance. This warranty gives you specific legal rights which may vary from state to state.

WINCO reserves the right to change or improve its products without incurring any obligations to make such changes or improvement on products purchased previously.

### **EXCLUSIONS:**

WINCO does not warrant Engines. Engines are covered exclusively by the warranties of their respective manufacturers, see enclosed warranties.

WINCO does not warrant Batteries, or Other Component Parts that are warranted by their respective manufacturers.

WINCO does not warrant modifications or alterations which were not made by WINCO, Inc.

WINCO does not warrant products which have been subjected to misuse and/or negligence or have been involved in an accident.

**WINCO<sup>®</sup>**

INCORPORATED

225 SOUTH CORDOVA AVE

LE CENTER MN 56057

Phone: 507-357-6831

# MAINTENANCE LOG

DATE	ITEM	WORK PERFORMED

P/N 60706-184-8009-30

**WINCO INC**<sup>®</sup>  
A Division of **DT** Dyna Technology Inc  
225 SOUTH CORDOVA AVE  
LE CENTER MN 56057  
Phone: 507-357-6831  
[www.wincogen.com](http://www.wincogen.com)