

INSTRUCTION MANUAL

INTRODUCTION

The information in this manual covers alternators using static excitation. This type of excitation will be discussed in detail in later paragraphs of this manual. The information contained should be studied carefully and the instruction book kept at hand for ready reference. Read very carefully the paragraphs on proper installation and maintenance.

The equipment described is the result of careful engineering design and manufacturing techniques. It has been completely inspected and tested before shipment. Carefully inspect on delivery for evidence of shipping damage. If damage has occurred it should be noted on the freight bill in order that a claim can be filed to recover the cost of the damage. If the damage appears to be of a major nature, the generator should not be operated until the fault has been corrected.

If you wish to contact your dealer or the factory make sure you mention the model and serial number of the generator set as listed on the nameplate on the side of the alternator.

Promptly fill in and return the guarantee card enclosed in the front of the manual. Winpower alternators are designed to deliver voltage and current identical to that of a normal power line. Equipment that can be operated on normal power can also be operated by the alternator, provided the capacity is not exceeded. It should be remembered that the power line, for all practical purposes, is backed by an unlimited generator.

ALTERNATOR

The alternator uses a static system for excitation and control of the voltage regulation. Carefully read the paragraph which describes the static excitation. The speed at which the armature turns determines the frequency of the current. A 60 cycle, 4 pole generator must be operated at approximately 1800 RPM and a 50 cycle generator at approximately 1500 RPM. Two pole machines operate at 3600 RPM for 60 cycle or 3000 RPM for 50 cycle.

The governor of the driving engine must have good response and stability. Frequency and voltage will vary in direct relation to rotational speed. The governor should regulate within 5% from no load to rated load. Speed regulation of 5% will result in frequency variation of 3 cycles. This variation in frequency is of little consequence to most equipment to be powered. The engine must have sufficient power to maintain speed under load. The best of governors cannot control an overloaded engine.

WHAT IS STATIC EXCITED TYPE ALTERNATOR?

The word "static" means without motion; thus the term "static excited" means that the excitation current for the field is supplied without the use of outmoded rotating type of excitation. Commutators and commutator brushes with the inherent problems of sparking and maintenance are not used.

In the Winpower static excited alternator, the alternating current output of the generator is rectified by means of a silicon diode bridge. Resulting direct current is used to supply the stationary field coils.

The excitation system also includes a circuit to regulate voltage as the load is varied. This system also provides a means to "force the field" during sudden momentary overload such as motor starting.

The control circuit has various forms depending on capacity and operation requirements. The majority of the models use a control (series) field which varies the total field strength in relation to change in load current. An additional control field bridge is used to rectify the current.

Larger models use a transformer with the primary in series with the load and the secondary connected to the bridge. By this means capacity requirements for brushes, diodes, slip rings, etc. are reduced.

Depending on design consistent with cost and function, some models use a revolving armature and others use a revolving field. In a revolving armature machine, the excitation field(s) is stationary and the voltage producing winding revolves. The revolving field design is "turned inside out". Voltage producing windings are stationary and the field winding revolves. See illustration in later pages of this manual.

LOAD CONNECTION

The means for load connection varies depending on order requirements, capacity and type of use. For portable use receptacles are usually provided for plug-in connection. Permanent installations are normally provided with terminal strips for load connection. Permanent connection should be made by a qualified electrician with full knowledge of code requirements. Consult the wiring diagram included in the manual.

MAINTENANCE

Little maintenance is required other than routine inspection and cleaning. Bearings are pre-lubricated and will have long life unless damaged by accident or carelessness. Excessive belt tension and mis-alignment should be avoided when that type of drive is used.

The interior and ventilating air passages should be kept clean and unobstructed. Brushholders and slip rings must be kept free from dirt, oil, paint and moisture. If compressed air is available it can be used effectively for cleaning. Consult the engine instruction manual for engine maintenance.

Standby equipment should be operated periodically even though normal power has not failed. If a problem has developed it can be corrected before an emergency situation arises.

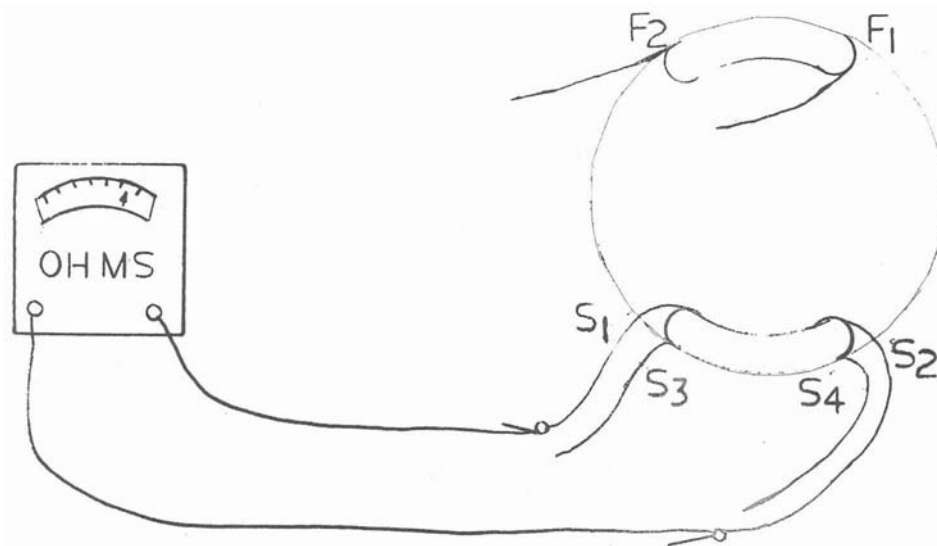

Note: The complete shunt field is wound in one coil and the series control field in the other.

Approximate Field Resistance at 25°C (77°F)

Coil		Resistance
H-1079	Shunt	89
H-1087	Series	.174 each Winding

TESTING A FIELD CIRCUIT

Disconnect field leads. Mark carefully for proper reconnection.

The series field resistance (S1 to S2, S3 to S4) is less than one ohm and is too low to measure with the average ohmmeter. A high resistance would indicate broken internal wires. There should be no deflection of the meter to an unpainted spot on the frame which would indicate a grounded coil. Make sure neither lead is in contact with the frame.

The resistance of the shunt field should be near to the range listed. An appreciable lower resistance would indicate shorted internal winding. Broken internal winding would result in no deflection. **Check also for a grounded coil.** A grounded coil can usually be corrected by repairing the insulation. Inspect for and smooth any sharp edge.

Note: Whenever the field coils have been removed and replaced or the generator disassembled, the field must be re-energized. For this purpose use a 120 to 25 volt AC stepdown transformer. The transformer should have a power cord on the 120 volt side. With the generator set in operation, plug the primary into a wall outlet. Insert the probes into one of the 120 volt receptacles in the load panel. Remove at once when voltage is indicated by a voltmeter connected to one of the other receptacles. **DO NOT USE A VARIABLE TRANSFORMER OR TEST LAMP. REVERSAL OF THE GROUND ON THE POWER LINE COULD BE DANGEROUS. THE FLASHING TRANSFORMER ISOLATES THE GROUND.**

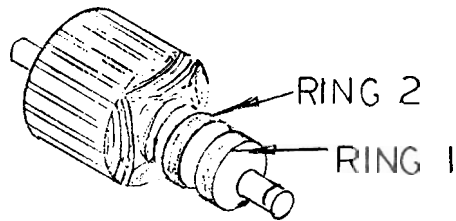

ARMATURE ASSEMBLY

Note: Before attempting to check an armature circuit, lift all brushes from slip rings.

The resistance of the armature is too low to be measured by the average ohmmeter. A circuit should be indicated between the rings.

If the armature circuit is complete, check for grounded windings from the rings to the armature shaft.

A "growler" is used in testing for shorted turn in the winding. This equipment can be found at any armature rewinding shop.

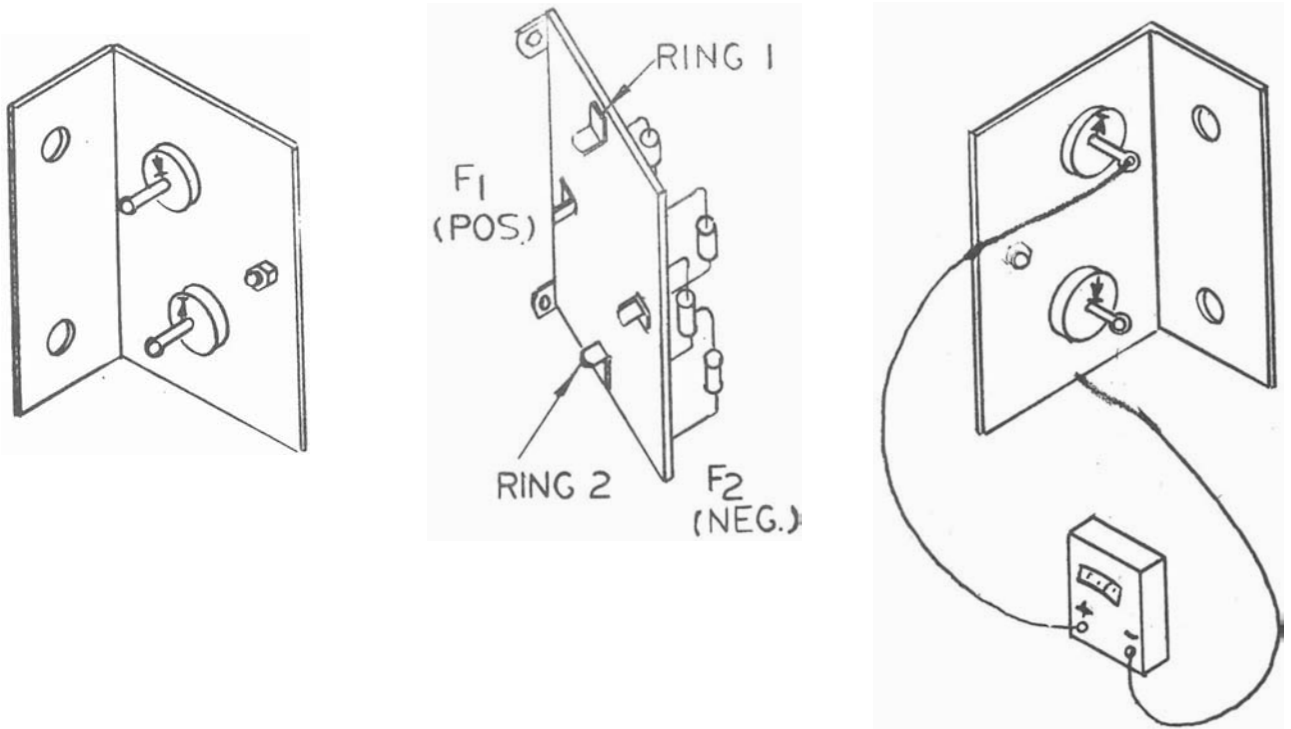

Note: Both diodes in each half of the control field bridge are pressed into the aluminum heat sink. Pressed in diodes require special tooling for replacement and cannot be changed in the field. Repair is made by replacement of assemblies.

Check for Defective Diode

1. Disconnect all external wiring from both AC and DC circuits. (Carefully mark the point of connection of each wire to assure proper reconnection.)
2. A diode that is in good order will conduct current in one direction and block in the opposite. The conducting direction is marked on the case by arrow (\rightarrow) on the larger and by a color band on the smaller (\leftarrow).
3. Use an ohmmeter (or a 1.5 volt flashlight battery and bulb as illustrated) to check the current direction. Connect positive at the base of the arrow and negative at the end to which the arrow points. (See illustration) A diode that conducts in both directions or neither direction is defective.

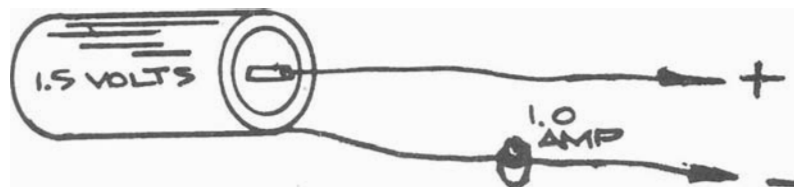

Alternate means for testing a diode if an ohmmeter is not available.

LOW OUTPUT VOLTAGE	
POSSIBLE CAUSE	REMEDY
Low Speed	1. Check for overload on the engine. 2. Defective governor. Check governor spring tension, tight or defective throttle levers and joints. 3. Defective engine.
High line loss. Indicated by lower voltage at load than at generator terminals.	Increase size of line wiring. Might also be the result of loose connections which will be indicated by excessive heating at the loose connections.
Shorted or grounded field coil.	See information for testing field circuits.
Defective compound field circuit.	See information for testing field circuits.
HIGH OUTPUT VOLTAGE	
Excessive speed.	Check governor linkage, spring tension, etc. Governor linkage must be free from dirt & gum.
EXCESSIVE HEATING	
Clogged ventilating inlet and/or outlet.	Clean and make sure interior is unobstructed.
Excessive heat from other equipment	Construct baffle or some means to direct heat in another direction.
Overload	Reduce load.
NO OUTPUT VOLTAGE	
Poor Brush Contact: Brushes tight in holder.	Clean Brushholder. Brush should move freely in holder.
Weak Brush Spring Tension	Brush spring tension should snap brush into contact with ring when lifted and released.
Film on Collector Rings caused by corrosive or dirty atmosphere.	Clean rings with fine sandpaper during rotation. Caution: Tape sandpaper to stiff cardboard for safety.
Defective Rectifier Bridge (See illustration for method of checking bridge.)	Replace defective bridge assembly. Find assembly number under DIODE ASSEMBLY in parts list.
Open field circuit (see illustration for method for checking).	Replace field coils.
Grounded or shorted field coil(s) (See illustration for method.)	Repair ground if possible. Replace shorted coils.
Loss of residual magnetism. This is a condition brought about by some unusual condition. It will always occur after disassembly.	See note under field assembly for procedure to restore magnetism.
Defective Armature: Shorted winding. This can be identified by the use of a "growler" at a competent re-winding shop. Grounded armature winding check by test lamp or high potential tester from collector rings to shaft. Open armature circuit. Measure circuit between rings with an ohmmeter. Note: 4 ring single phase armatures will have a circuit between rings 1 & 2 and rings 3 & 4 (numbered from bearing end). There should be no circuit on any other combination. All others should have a circuit between any pair of rings.	Replace the armature (Include generator model and serial number on the order.)

FM6V2-B PARTS LIST

REF. NO.	PART NO.	DESCRIPTION	REQUIRED
1	S-6650-2	End Cover	1
	3522	Screw 1/4-20 x 1/2	2
	1299	Washer	2
2	A-606-1	Fan	1
	1184	Washer	1
	1115	Washer	1
	3568	Screw 5/16-24 x 3/4	1
3	G-5654	Generator Base	1
	1185	Washer	8
	3578	Washer	4
	1116	Washer Int. T.T.	4
4	G-5572-5	Field Frame Ass'y	1
5	J-570	Coil Shield	4
6	G-5567	Field Pole	2
	1116	Washer	6
	3582	Screw 3/8-16 x 1-1/2	6
7	H-1079	Field Coil-Shunt Field	1
	H-1078	Field Coil-Series Field-Bottom Fr.	1
8	S-859	Lift Ring	1
	4616	Nut 1/2-13	1
9	G-5566-1	Brush Gear Assy (see detail)	1
	S-6722	Stud 5/16-24 x 2-1/2	4
	1115	Washer 5/16 Int. T.T.	12
	4612	Nut 5/16-24	12
10	V-1039	Handy Box	1
11	EE-910	Handy Box Cover	1
	1115	Washer 5/16 Int. T.T.	2
	3540-1	Screw 5/16-18 x 2-1/2	2
12	W-134	Grommet	1
13	G-5568-5	Armature Assembly	1
14	D-8	Bearing	2
15	11107	Retainer Ring	2
16	I-874-2	Drive End Bell	1
	1115	Washer 5/16 Int. T.T.	4
	3547	Screw 5/16-18 x 1-1/4 Lg.	4
17	S-6242	Bearing Retainer	2
	5805	Nut 1/4-20	4
	3526	Screw 1/4-20 x 1	4
	Z-2218	Wiring Diagram E-8412	

E-8412

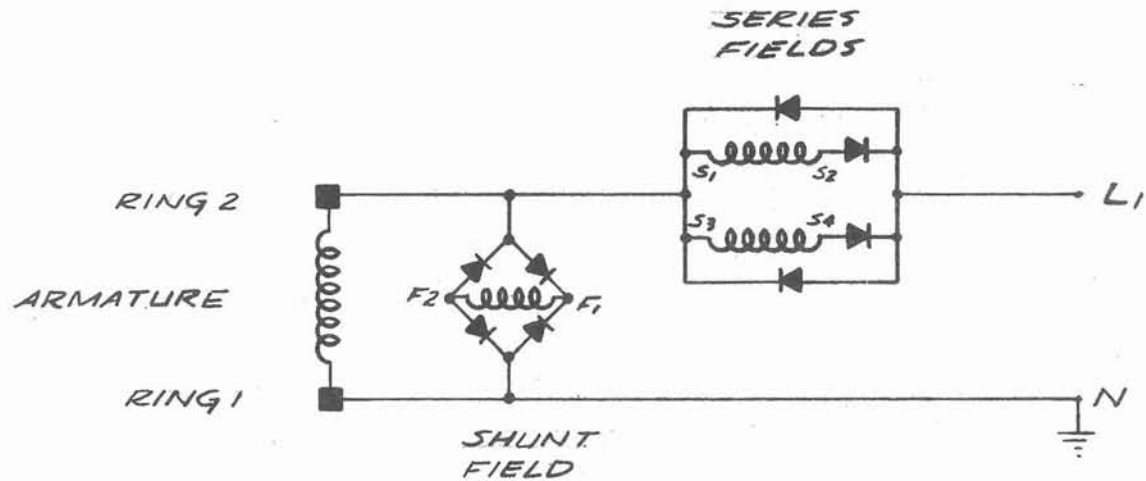

FM6V2-B

CHANGE					CHG. REQUEST	NO. REQ'D.	MICROFILM DATA	WIRING DIAGRAM	
CHANGE	WAS ORIGINALLY	DATE	CHK'D	CHG. REQUEST	NO. REQ'D.	MICROFILM DATA	SCALE	MODEL NO.	PART NO.
							~		Z-2218
TOLERANCE ON DIMENSIONS NOT OTHERWISE SPECIFIED					REMOVE ALL BURRS BREAK ALL SHARP MACHINED EDGES			DATE 1-11-71	CHK'D
							DWN T.C.G.		
								WINPOWER MFG. CO. NEWTON, IOWA	

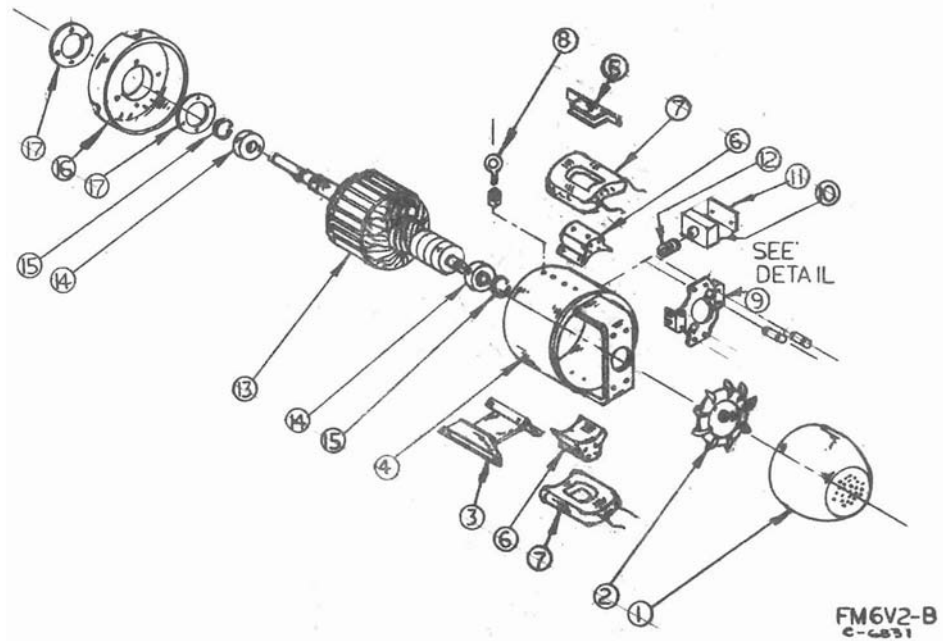

FM6V2-B
C-6831

CHANGE	WAS ORIGINALLY	DATE	CHK'D	CHG. REQUEST	NO. REQ'D	MICROFILM DATA
TOLERANCE ON DIMENSIONS NOT OTHERWISE SPECIFIED		DECIMAL ±		REMOVE ALL BURRS		
		FRACTIONAL ±		BREAK ALL SHARP MACHINED EDGES		
		ANGULAR ±				

ISOMETRIC DRAWING	
SCALE	MODEL NO.
DATE 1-29-71	PART NO.
BY DON R	CHK'D
WINPOWER MFG. CO. NEWTON, IOWA	

C-6831

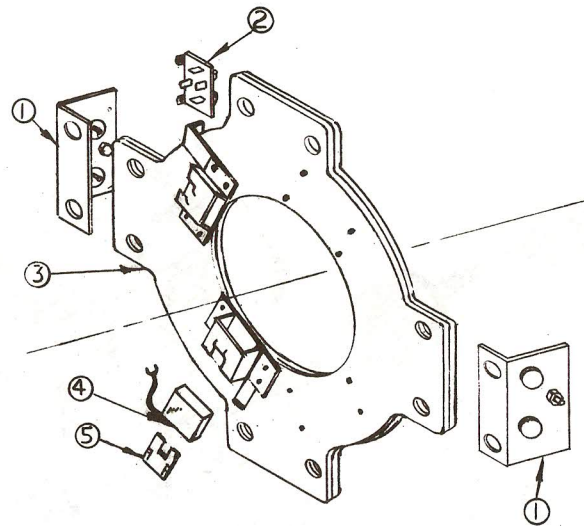

BRUSH GEAR AND RECTIFIER ASSEMBLIES

Ref. No.	Description	Part No.	Qty.
1	Series Field Rectifier Assembly	G-5570-6	2
2	Shunt Field Rectifier Assembly	G-5299	1
3	Brush Gear Assembly Complete	G-5566-1	1
4	Brushes	Y-51	4
5	Springs	G-3422	4

CHANGE	WAS ORIGINALLY	DATE	CHK'D	CHG. REQUEST	NO. REQ'D.	MICROFILM DATA
TOLERANCE ON DIMENSIONS NOT OTHERWISE SPECIFIED			DECIMAL \pm	REMOVE ALL BURRS BREAK ALL SHARP MACHINED EDGES	MATERIAL _____	
			FRACTIONAL \pm			
			ANGULAR \pm			

ISOMETRIC-BRUSHGENIC	
SCALE _____	MODEL NO. _____
DATE 1-29-71	PART NO. _____
BYW Done	CHK'D _____
WINPOWER MFG. CO. NEWTON, IOWA	

C-6332