

FM3V2-05

3600
R.P.M.

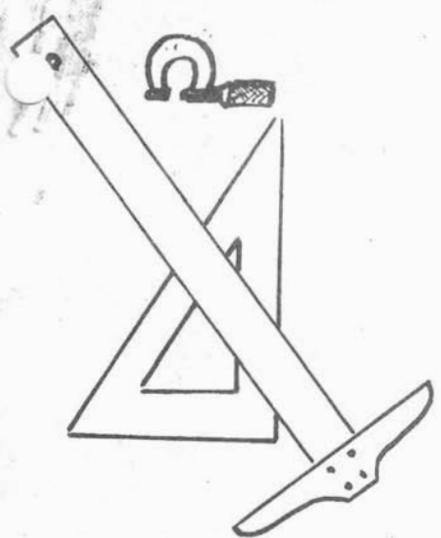

GENERATOR

Instruction Manual

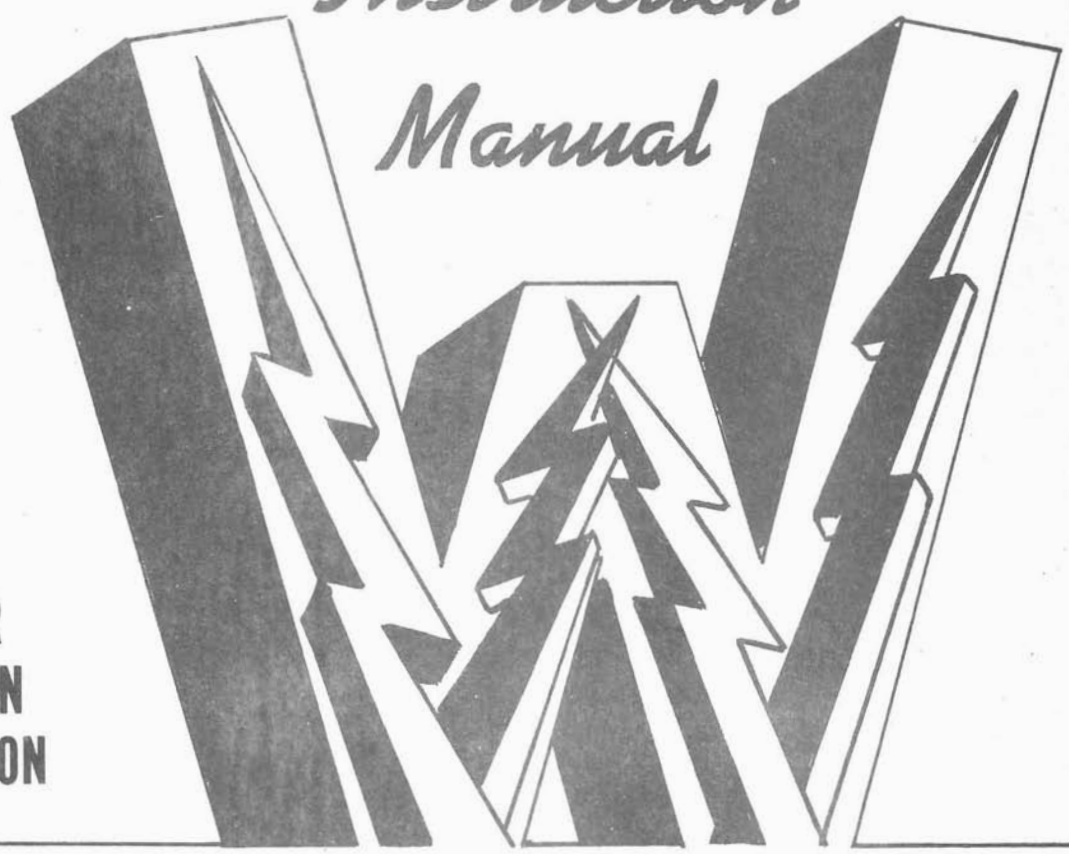

POWER
YOU CAN
DEPEND ON

**Better GENERATORS
through
Better TECHNOLOGY^v**

- GENERATOR ONLY
- AIR COOLED DIESEL GENERATOR SET
- AIR COOLED GASOLINE GENERATOR SET

**WIND
POWER**

MFG. CO. NEWTON, IOWA

50208

INSTRUCTION MANUAL

INTRODUCTION

The information in this manual covers revolving field type alternators using static excitation. This type of excitation will be discussed in detail in later paragraphs of this manual. **The information contained should be studied carefully and the instruction book kept at hand for ready reference.** Read very carefully the paragraphs on proper use and maintenance.

The equipment described is the result of careful engineering design and manufacturing techniques. **It has been thoroughly inspected and tested before shipment.** Carefully inspect on delivery for evidence of shipping damage. If damage has occurred it should be noted on the freight bill in order that a claim can be filed to recover the cost of the damage. **If the damage appears to be of a major nature, the fault should be corrected before using.**

If you wish to contact your dealer or the factory, make sure you mention the model and serial number as listed on the nameplate on the side of the alternator.

Winpower alternators are designed to deliver voltage and current identical to that of a normal power line. **Equipment that can be operated on normal power can also be operated by the alternator, provided the capacity of the alternator is not exceeded.** **It should be remembered that the power line, for all practical purposes, is backed by an unlimited generator.**

Promptly fill in and return the guarantee card enclosed in the front of the manual.

ALTERNATOR

The alternator is a revolving field type, using a static system for excitation and control of the voltage regulation. **The section below describes the static excitation.** The rotor in a two pole machine must revolve at 3600 RPM for 60 cycle current and at 3000 RPM for 50 cycle. Frequency varies in direct relation to the speed of rotation. The governor of the driving engine or tractor will therefore determine the variation in frequency. An unstable governor or one that droops in speed excessively under load will result in excessive frequency variation. A droop at 5% in speed will result in a frequency variation of 3 cycles. This variation is of little consequence for most equipment to be powered. The driving engine should have sufficient power to maintain speed under load. The best of governors cannot control an overloaded engine.

WHAT IS STATIC EXCITATION?

The word "static" means without motion; thus, the term "static excited" means that the control system which provides the current for the electro-magnetic field is provided without the use of an out-moded revolving DC armature. Commutators and commutator brushes with the inherent problem of sparking and maintenance are eliminated. The use of a mechanical voltage regulator with vibrating or multiple moving contacts is also eliminated.

Direct current is required for the electro-magnetic field. A single coil is wound in the alternator stator (the stationary winding) to provide the current for the base field. This coil is entirely separate from the main winding and is at right angles in mechanical position. The AC voltage generated in this coil is fed to a full wave silicon diode bridge to provide rectified direct current for the base field. As the field is the rotating component, the current connection is accomplished by the use of slip rings and brushes. The base field is connected to ring #1 (nearest to the bearing) and ring #3. The base field is designed to provide magnetic lines of force required to generate rated voltage with no load on the alternator.

In order to maintain close voltage regulation as the load is varied, a control field is used. The control circuit consists of an additional full wave bridge, in series with one load line, and a control winding on the field poles. The control field is connected to ring #1 and ring #2. When a load is connected to the alternator, this current is rectified and fed through the control field winding. By this means, the total strength of the field is varied in relation to the load.

The description of static excitation opened with the statement that "static" is defined as without motion. In later paragraphs the revolving field has been discussed. To avoid confusion, a word of explanation is in order. There must be some relative motion between the coils which generate voltage and the magnetic field which causes the voltage to be produced. In a revolving field generator, the winding that produces the voltage is stationary and the field poles revolve. The reverse is true in the case of a revolving armature generator; the field is stationary and the voltage producing winding rotates.

LOAD CONNECTION

Standard connection for 2000 watt, single voltage alternators use duplex grounding type receptacles. Special applications, to be used as part of other equipment, may provide a plate to accept conduit fittings. Short leads are brought out for connection.

Larger capacity machines are provided with an outlet box enclosing a terminal strip for connection. Optional panels are available for capacities above 2000 watts. These are designed to be installed in the field. A voltage indicator, a circuit breaker, 15 ampere duplex receptacle and a 50 ampere receptacle are included in the special panels. The voltage indicator uses a color band of red and green in place of a numbered scale. Voltage and frequency are correct in the green portion of the color band.

MAINTENANCE

Little maintenance is required other than routine inspection and cleaning. The bearings are pre-lubricated and will be a long life item unless damaged by accident or excessive driving belt tension.

The interior of the alternator should be clean and unobstructed. Slip rings and brushholders be kept free from dirt, oil, and moisture. If compressed air is available it can be used effectively for cleaning.

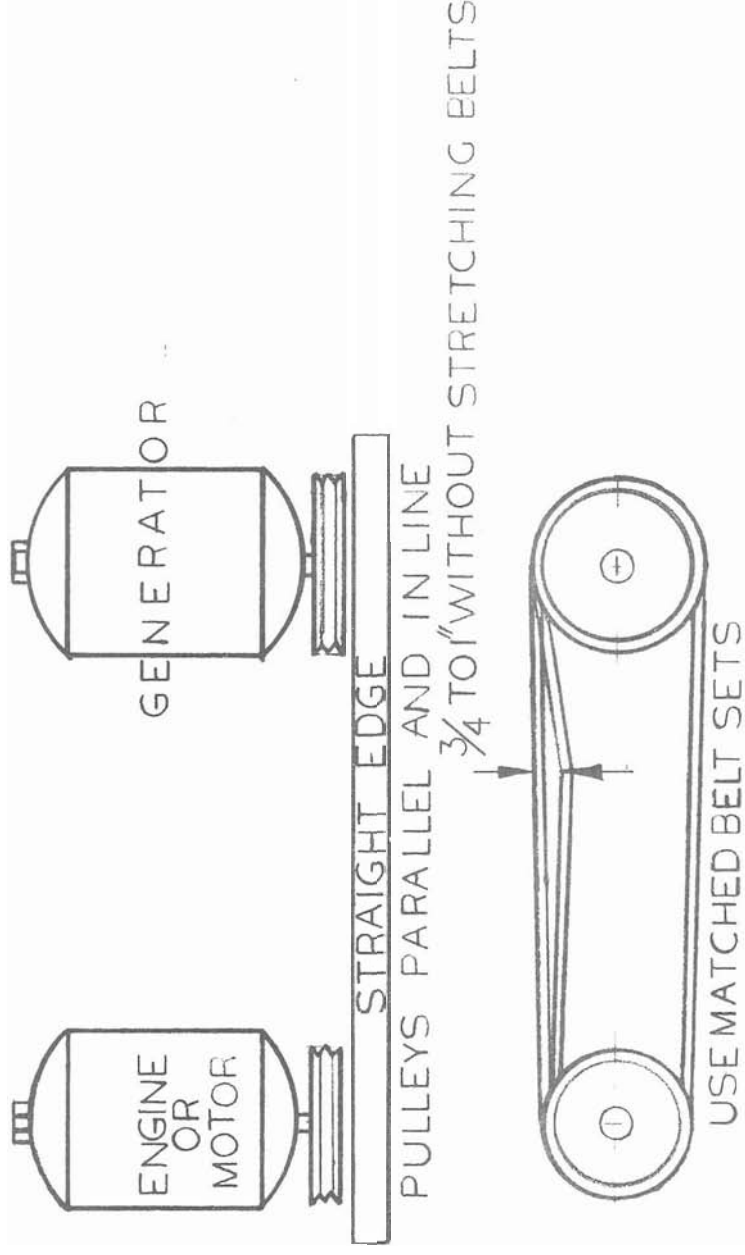

SHEAVE & BELT ALIGNMENT

SERVICE DIAGNOSIS

LOW OUTPUT VOLTAGE

POSSIBLE CAUSE	REMEDY
Low Speed	<ol style="list-style-type: none"> 1. Check for overload on the engine. 2. Defective governor. Check governor spring tension, tight or defective throttle levers and joints. 3. Defective engine.
High line loss. Indicated by lower voltage at load than at generator terminals	Increase size of line wiring. Might also be the result of loose connections which will be indicated by excessive heating at the loose connections.
Shorted or grounded field coil. In some cases one coil only, that is shorted or grounded, will reduce voltage to approximately one half of rating.	See information for testing field circuits.
Defective compound field circuit. Field connected to Rings #1 and #2	See information for testing field circuits.
Defective control field bridge.	See information on testing bridge assemblies.

HIGH OUTPUT VOLTAGE

Excessive speed	Check governor linkage, spring tension, etc. Governor linkage must be free from dirt & gum.
-----------------	---

EXCESSIVE HEATING

Clogged ventilating inlet and/or outlet.	Clean, make sure interior is unobstructed.
Excessive heat from other equipment	Construct baffle or some means to direct heat in another direction.
Overload	Reduce Load

NO OUTPUT VOLTAGE

Poor Brush Contact: Brushes tight in holder	Clean Brush Holder. Brush should move freely in holder.
Weak Brush Spring Tension	Brush spring tension should snap brush into contact with ring when lifted and released.
Film on Collector Rings caused by corrosive or dirty atmosphere.	Clean rings with fine sandpaper during rotation. Caution: Tape sandpaper to stiff cardboard for safety.
Defective Rectifier Bridge (See illustration for method of checking bridge)	Replace defective bridge assembly. Find assembly number under DIODE ASSEMBLY in parts list.
Open field circuit (see illustration for method for checking)	Replace Rotor Assembly.
Grounded or shorted field coil (s) (See illustration for method)	Replace Rotor Assembly.
Loss of residual magnetism. This is a condition brought about by some unusual condition. It will always occur after disassembly.	See note under field assembly for procedure to restore magnetism.
Defective Stator: Shorted winding. This can be identified by the use of a "growler" at a competent re-winding shop. Grounded winding. Check by test lamp from stator winding to frame. Open winding circuit. Check all circuits for continuity. IE: S ₂ to S ₁ , S ₄ to L ₁	Replace the Stator. See illustration for testing method. (Include generator model and serial number on the order.)

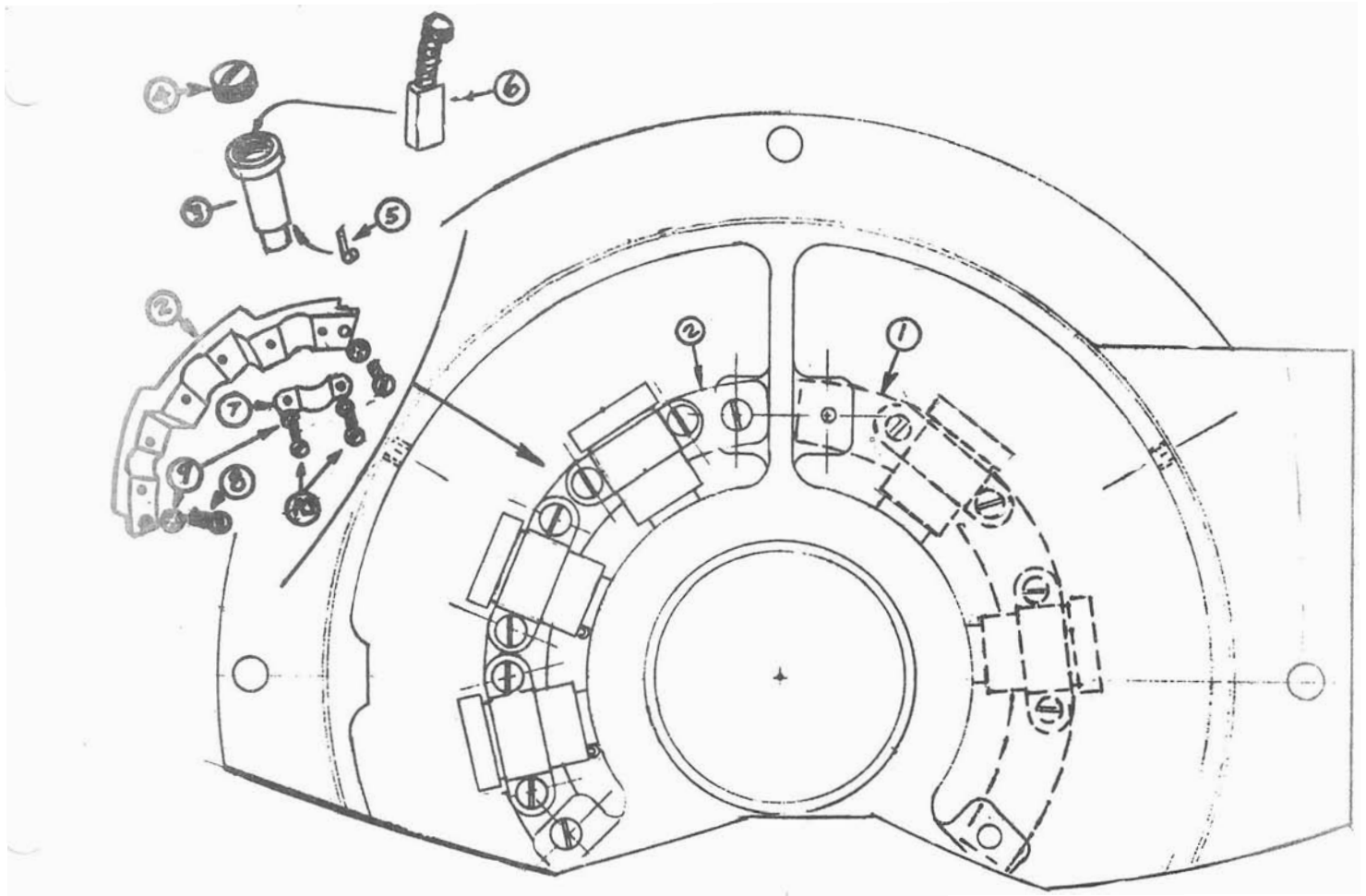

BRUSH HOLDER ASSEMBLY

Models rated at 2000 watts and under use one bracket assembly ② as shown in solid lines. Models above that rating have two brushes on rings #1 and #2 (numbering from end of shaft) and use added bracket ① as shown in dotted lines.

Note: When replacing brushes, the most simple method is to disconnect the entire bracket assembly by removing the screw at each end. The bracket can then be tilted forward for easy access to the brush holder caps.

- | | | | | | |
|----|---------|------------------------------|-----|--------|----------------------|
| 1. | A-745 | Brush holder bracket (right) | 6. | Y-114 | Brush |
| 2. | A-746 | Brush holder bracket (left) | 7. | S-6096 | Clamp |
| 3. | B-701 | Brush holder | 8. | #2005 | Screws |
| 4. | B-791-A | Cap | 9. | #1110 | Lock Washer |
| 5. | B-701-B | Clip | 10. | #2652 | Screw - Self tapping |

BRIDGE ASSEMBLIES

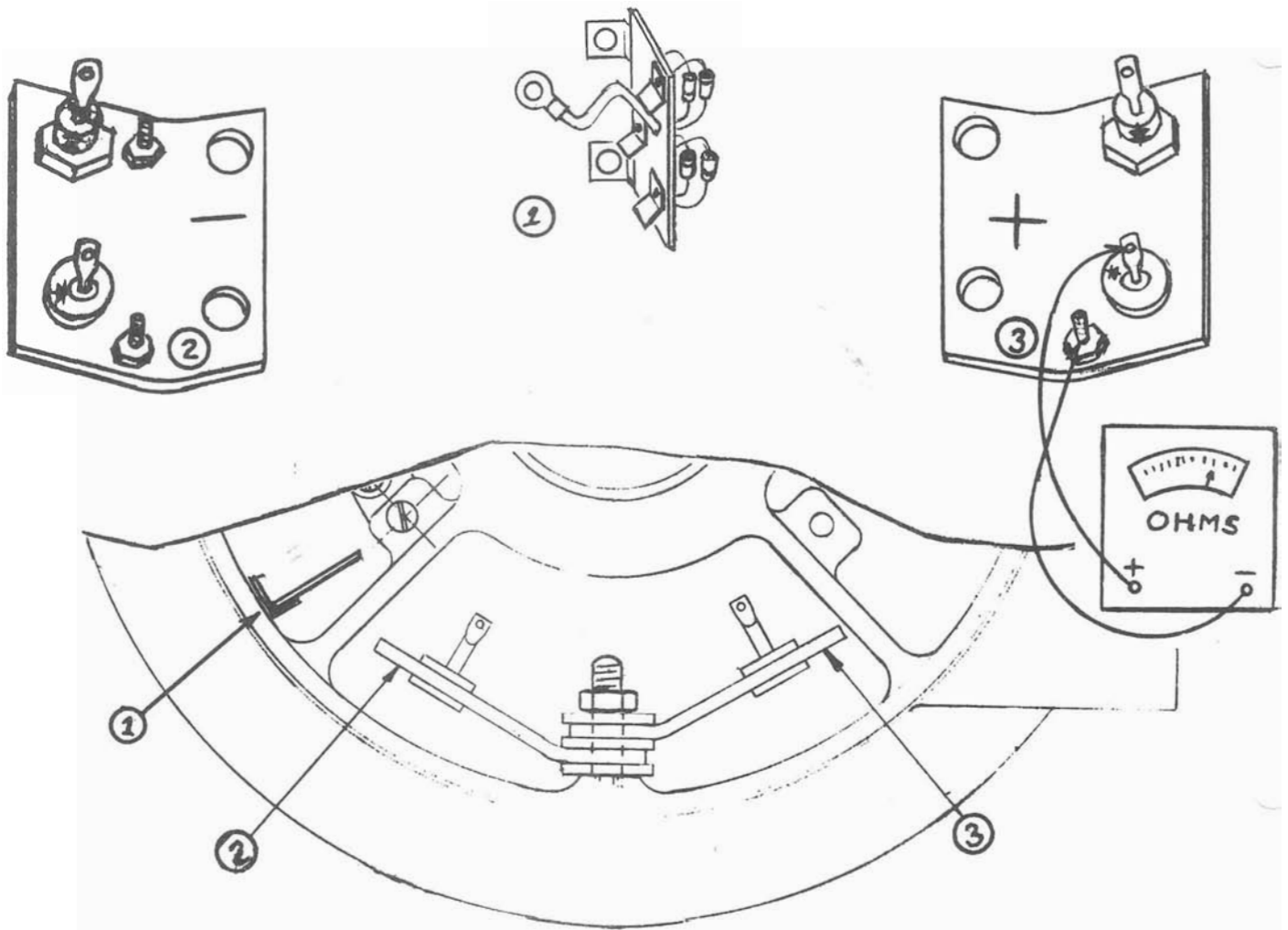

1. Base Field Rectifier Bridge Assembly
2. Negative Control Field Rectifier Bridge Assembly
3. Positive Control Field Rectifier Bridge Assembly

Note: Both diodes in each half of the control field bridge are pressed into the aluminum heat sink on Models BR2036B and BR4036B5. Models BR4036B, BR4036C and BR6036C have one diode in each half that is stud mounted. **Pressed in diodes require special tooling for replacement and cannot be changed in the field. Repair is made by replacement of assemblies.**

Check for Defective Diode

1. Disconnect all external wiring from both AC and DC circuits. (Carefully mark the point of connection of each wire to assure proper re-connection).
2. A diode that is in good order will conduct current in one direction and block in the opposite. The conducting direction is marked on the case by an arrow (\rightarrow) on the larger and by a color band on the smaller ($\overline{\text{CG}}$).
3. Use an ohmmeter (or a 1.5 volt flash light battery and bulb as illustrated) to check the current direction. **Connect positive at the base of the arrow and negative at the end to which the arrow points.** (See illustration) A diode that conducts in both directions or neither direction is defective.



Alternate means for testing a diode if an ohmmeter is not available.

FIELD ASSEMBLY

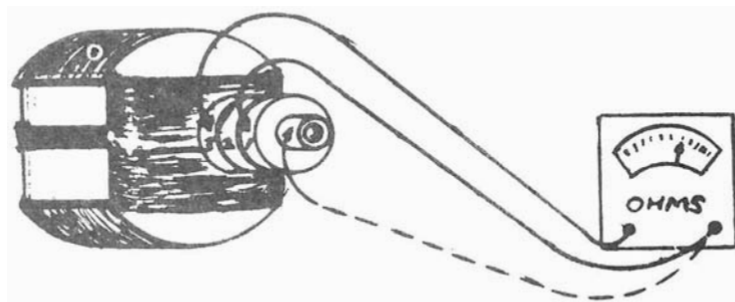

Resistance of Field Circuits at 25°C (77°F)

Model	Base Field (Ring #1 to 3)	Control Field (Ring #1 to 2)
BR4036B5	43 to 53 ohms	Less than 1 ohm
BR2036B	32 to 42 ohms	Less than 1 ohm
BR4036B	43 to 53 ohms	Less than 1 ohm
BR4036C	43 to 53 ohms	Less than 1 ohm
BR6036C	47 to 57 ohms	Less than 1 ohm

Note: When ordering replacement field assemblies, be sure to include model and serial number from nameplate on alternator frame.

TESTING A FIELD CIRCUIT

Make sure that all brushes are not in contact with the slip rings. If the alternator has not been disassembled, paper inserted between the brush and slip ring will serve as insulation. The complete brushholder bracket can be removed if this procedure is preferred, by removing the screws and nuts at each end of the bracket. The brush gear may use one bracket or two brackets, depending on the capacity of the alternator. When two are used, both must be insulated or disconnected.

To measure the resistance of the base field, touch the ohmmeter leads to ring #1 and #3 as shown in the illustration. Measure from rings #1 and #2 for the control field.

A resistance appreciably lower than shown on the table indicates shorted turns in one or both field coils. The resistance of less than one ohm on the control field is too low to measure accurately with the average ohmmeter. A complete circuit between rings should be indicated. A high resistance would indicate a broken connection.

A grounded field circuit can be identified by connecting the meter from the slip rings to the rotor shaft.

NOTE: Occasionally an alternator will lose residual magnetism. It is very unusual unless the alternator has been dis-assembled, in which case it will be necessary to "flash the field" on the first start.

(continued)

FIELD ASSEMBLY (Continued)

A step down transformer with a nominal 125 volt primary winding and from 15 to 30 volt secondary can be used for this purpose. **The primary** should have a cord with a plug for a wall receptacle. The secondary should have extension leads with insulated probes. With the alternator operating, plug into the wall outlet and insert the probes momentarily into the 125 volt convenience outlet. For equipment not furnished with the outlet, touch the probes to the connection of L1 and L2. A momentary contact is all that is required. The transformer assembly can be purchased from the factory at a nominal cost if not available locally.

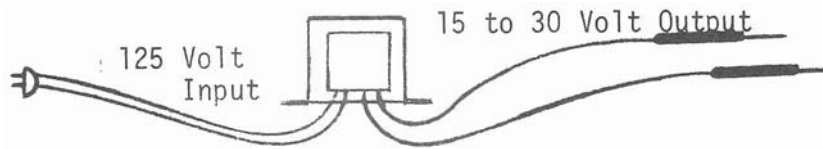

STATOR ASSEMBLY

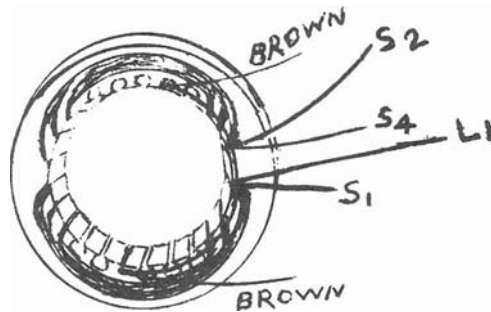

Note: When ordering replacement stator assemblies be sure to include the model and serial number from the nameplate on the side of the generator.

The stator assembly has a winding to develop voltage for the base field. The lead extensions from this winding are colored brown. Connection from this winding is to the base bridge.

A single, two pole winding is used for two wire, single voltage models. This winding connects to the control (Series) field bridge. The control bridge is divided into a positive and a negative side and is in series with the load. (See bridge assembly illustration)

Three wire, dual voltage models use two identical, two pole windings. Each winding generates 125 volts. The voltage from either line to neutral is, therefore, 125. From L1 to L2 the winding is in series for 250 volt output.

When a fault in the stator is suspected each individual winding should be checked. The resistance of the separate windings will be low, less than one ohm, but a complete circuit should be indicated. IE: #S₁ to #S₂, #S₄ to #L₁.

The various windings should also be checked for ground. For this purpose connect an ohmmeter from a bare spot on the frame to one lead of each coil. A meter deflection indicates a grounded winding.

When all stator leads are disconnected, there should be no circuit from one winding to any other. If a circuit is indicated the winding is shorted.

If any of the above conditions are indicated, the stator assembly must be replaced.

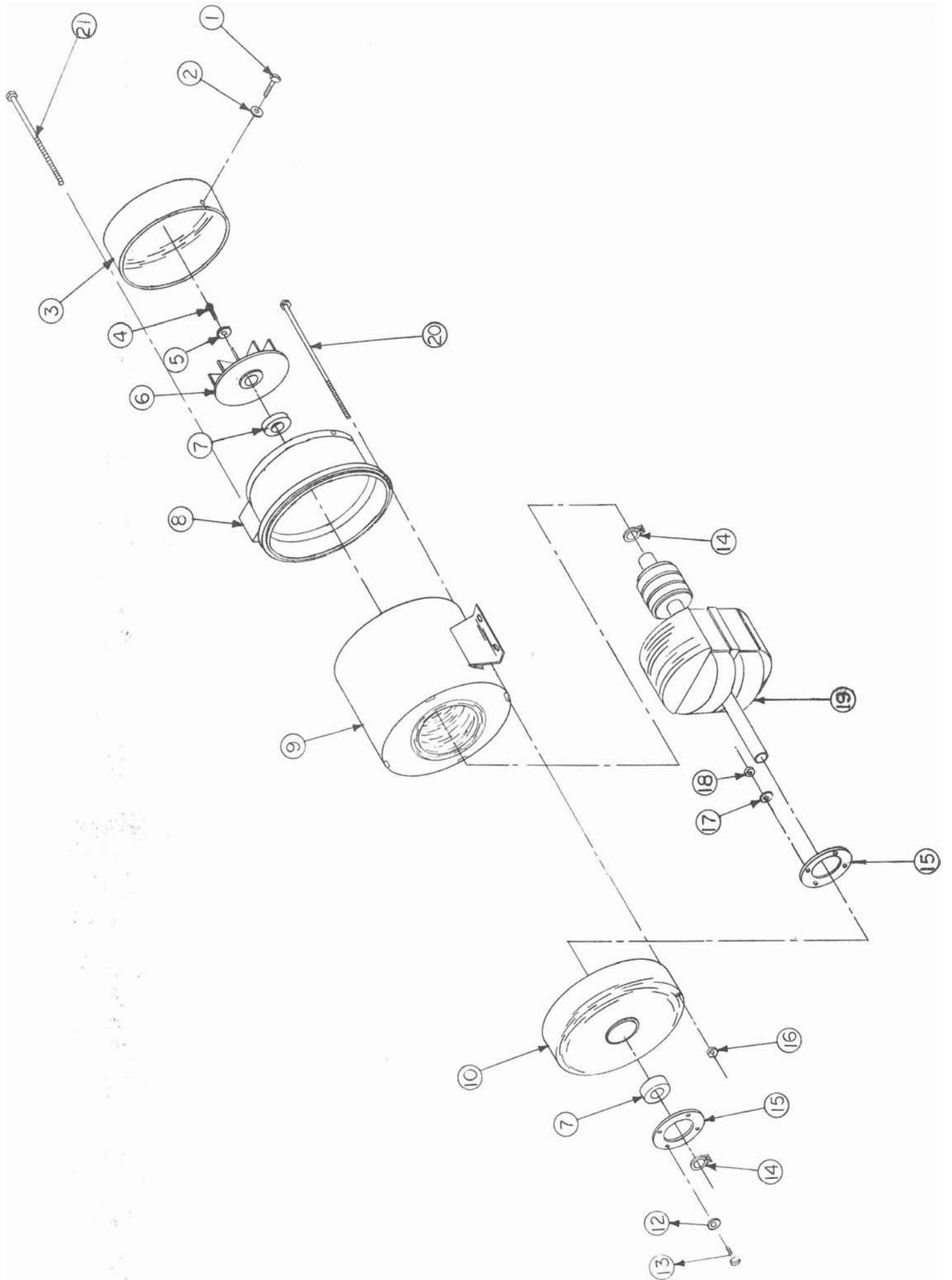

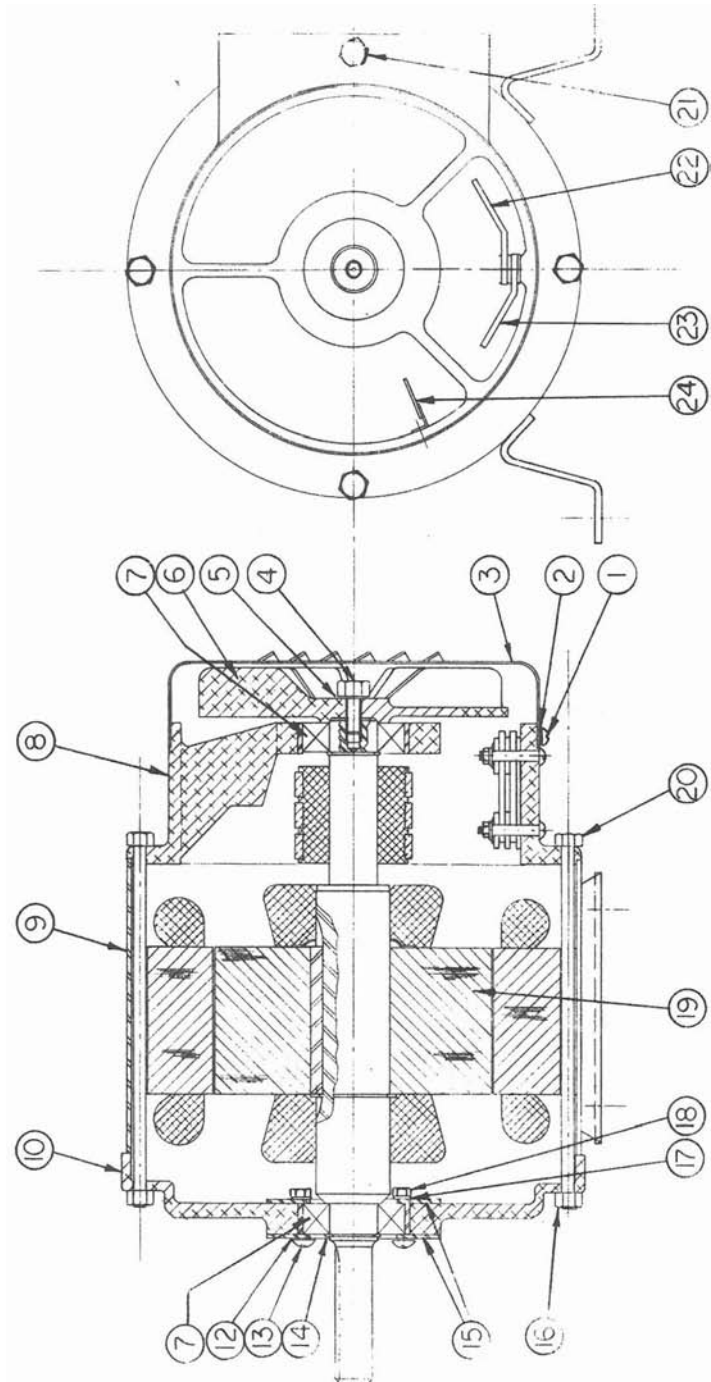

PARTS LIST
FM3V2-DS

<u>PART NO.</u>	<u>DESCRIPTION</u>	<u>QUANTITY</u>
G-5208-7	Stator Ring Assembly	1
G-5285-7	Rotor Assembly	1
D-59	Bearing	2
A-722-4	Drive End Bell	
S-6242	Bearing Retainer	2
4074-4	Thru-Bolt 1/4-20x9-1/4"	1
4074-2	Thru-Bolt 1/4-20x7-1/4"	3
5805	Nut 1/4-20	4
A-727	Fan	1
V-1059	End Hood	
EE-900	Outlet Box	
6105	Grommet	2
EE-910	Outlet Box Cover Blank	1
S-6391	Cover Plate	
A-746	Brushholder Bracket - Left	1
A-745	Brushholder Bracket - Right	1
B-701	Brushholder	5
B-701-1	Cap	5
S-6096	Clamp Brushholder	5
G-5297-2	Series Field Rectifier Assy., Pos.	1
G-5298-2	Series Field Rectifier Assy., Neg.	1
G-5299	Shunt Field Rectifier Assembly	1
Y-114	Brushes	5

WIRING DIAGRAM

Z-2133 E-8147

MAIN STATOR

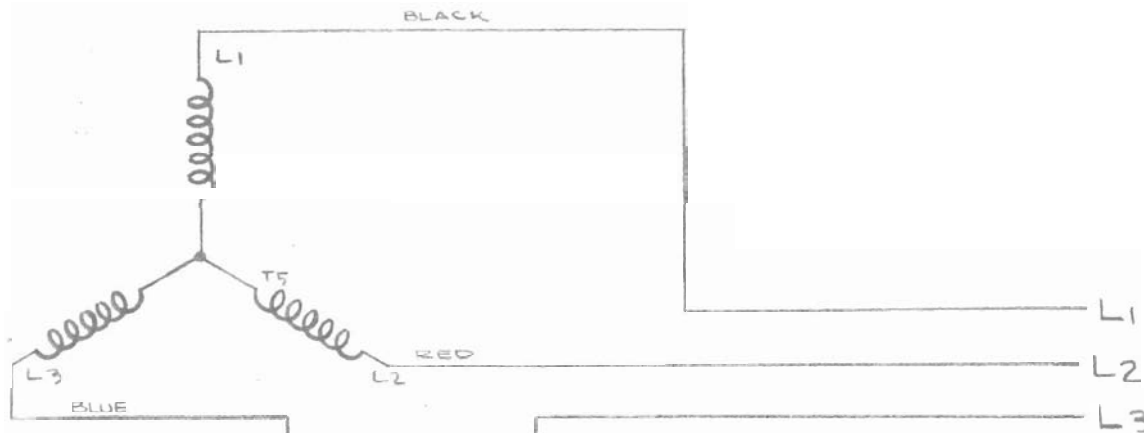

EXCITER STATOR

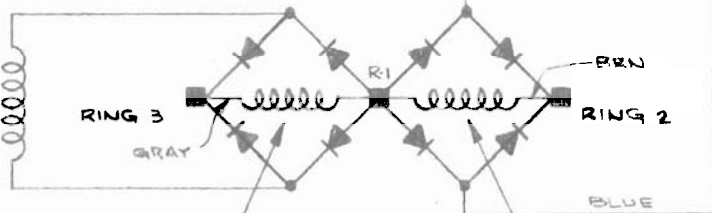

SHUNT FIELD

SERIES FIELD

APR 6 1970

A	GEN. REVISION F-1685	4-1-70	T.C.G.							
CHANGE	WAS ORIGINALLY	DATE	CHK'D	CHG. REQUEST						
TOLERANCE ON DIMENSIONS NOT OTHERWISE SPECIFIED			DECIMAL ±	REMOVE ALL BURRS BREAK ALL SHARP MACHINED EDGES	NO. REQ'D.	MICROFILM DATA				
			FRACTIONAL ±							
			ANGULAR ±							
MATERIAL										

WIRING DIAGRAM	
SCALE ~	MODEL NO.
DATE 2-2-70	PART NO. Z-2133
DWN TCG.	CHK'D

WINPOWER MFG. CO.
NEWTON, IOWA