

WINGO[®] INC

A Division of **DTE** Dyna Technology Inc

INSTALLATION INSTRUCTIONS TDM76 TRAILER KIT

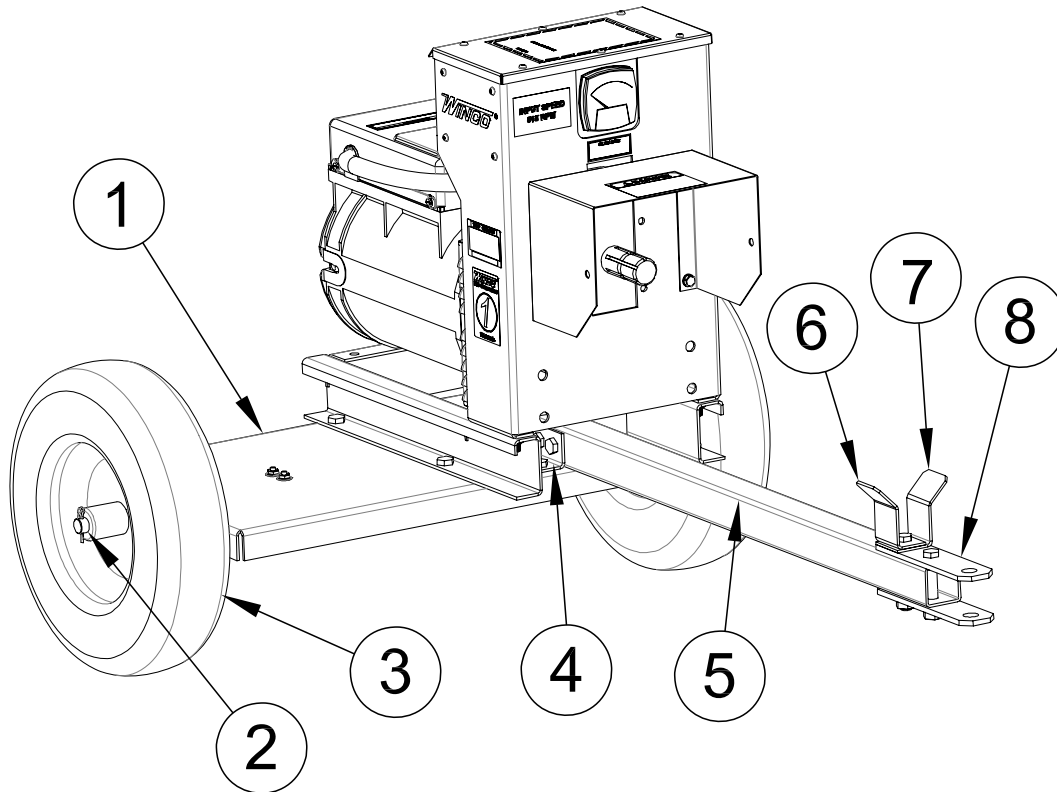

COMPONENT LIST

REF. #	PART #	DESCRIPTION	QTY.
1	300084-1	Base	1
2	300085-1	Axle	1
3	43657-000	Wheel	2
4	300081-1	Tongue Support	2
5	300083-1	Tongue	1
6	300161-2	Shaft Support	1
7	300161-1	Shaft Support	1
8	300082	Hitch	2
18	64006-000	Decal	1
	TDM76-1	Parts Bag	1
	16343-000	Axle Protector	2

STEP 1

- Open hardware bag and separate components.

FASTENERS & MISC. COMPONENTS (not shown in actual size)

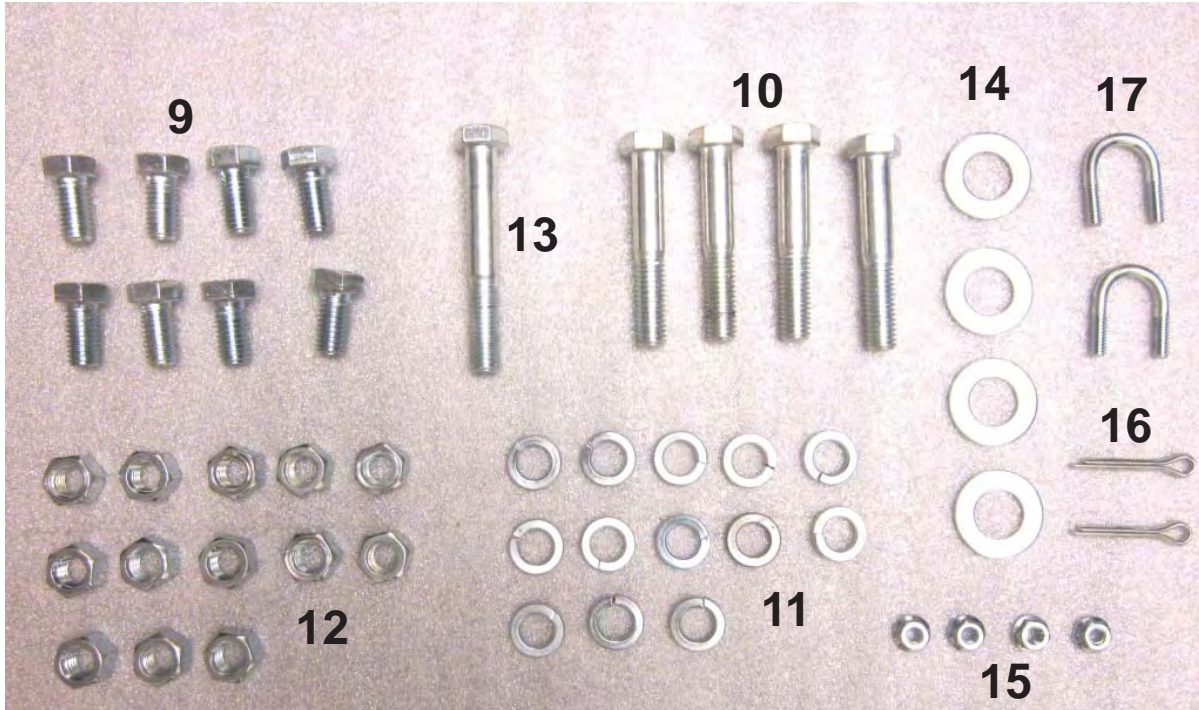

HARDWARE & FASTENER LIST

REF #	PART #	DESCRIPTION	QTY
9	48178-000	1/2" X 1" Bolt	8
10	57580-007	1/2" X 3" Bolt	4
11	636-000	1/2" Split Lock Washer	13
12	1744-000	1/2" Hex Nut	13
13	57580-002	1/2" X 3 1/2" Bolt	1
14	1178-000	Flat Washer	4
15	16248-000	1/4" Flange Nut	4
16	20979-000	Cotter Pin	2
17	300163	U-Bolt	2

STEP 2

- Attach tongue supports (ref. 4) to the base (ref. 1) using the hardware provided (ref. 9, 11, 12). Place tongue (ref. 5) into the tongue supports (ref. 4) and attach using the hardware provided. (ref. 10, 11, 12). Place hitch pieces (ref. 8) and tongue supports (ref. 6, 7) on the tongue (ref. 5) and attach using the hardware provided (ref. 10, 11, 12, 13).

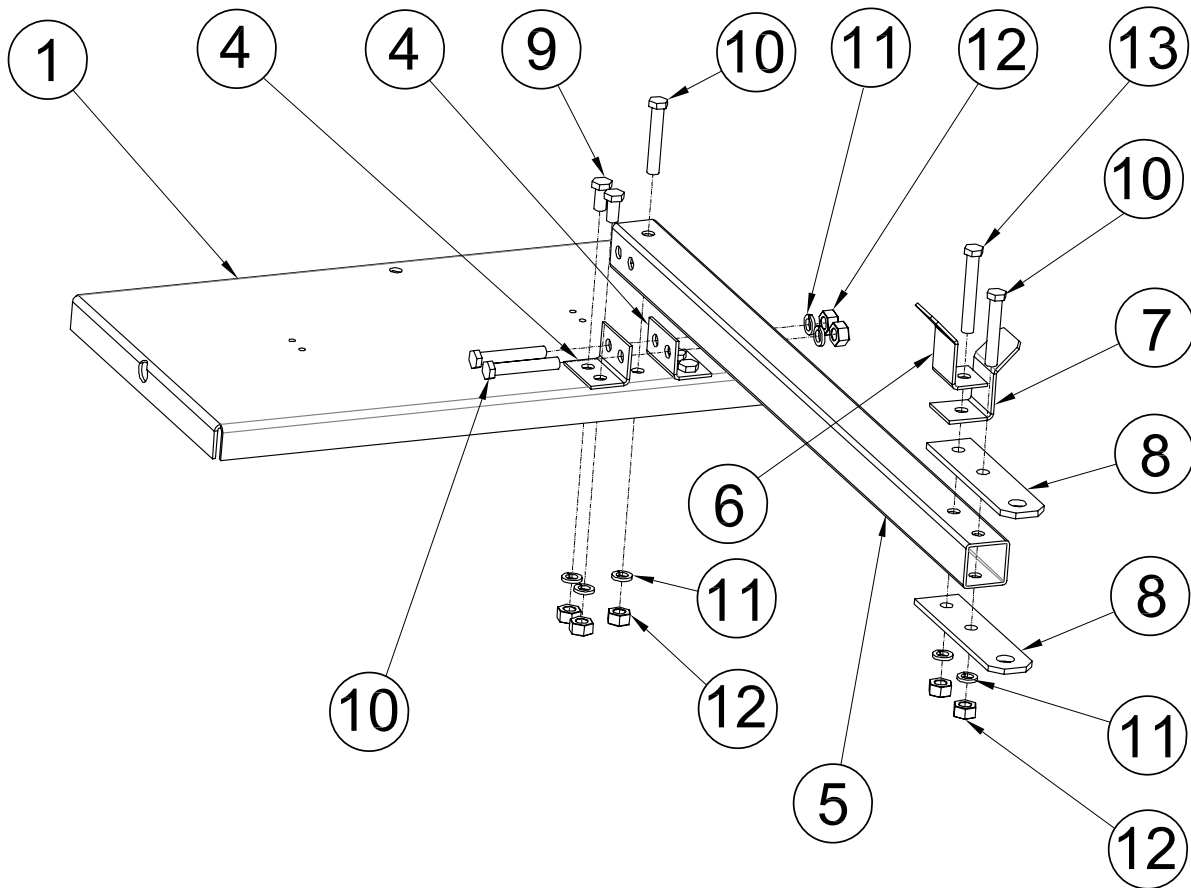

STEP 3

- Slide the axle (ref. 2) through the holes in the base (ref. 1). Slide one washer (ref. 14) onto each end of the axle. Lift the base and tongue assembly and slide the wheels (ref. 3) on the axle. Place the other two washers (ref. 14) on the axle. Place the cotter pins (ref. 16) through the axle and bend to secure.

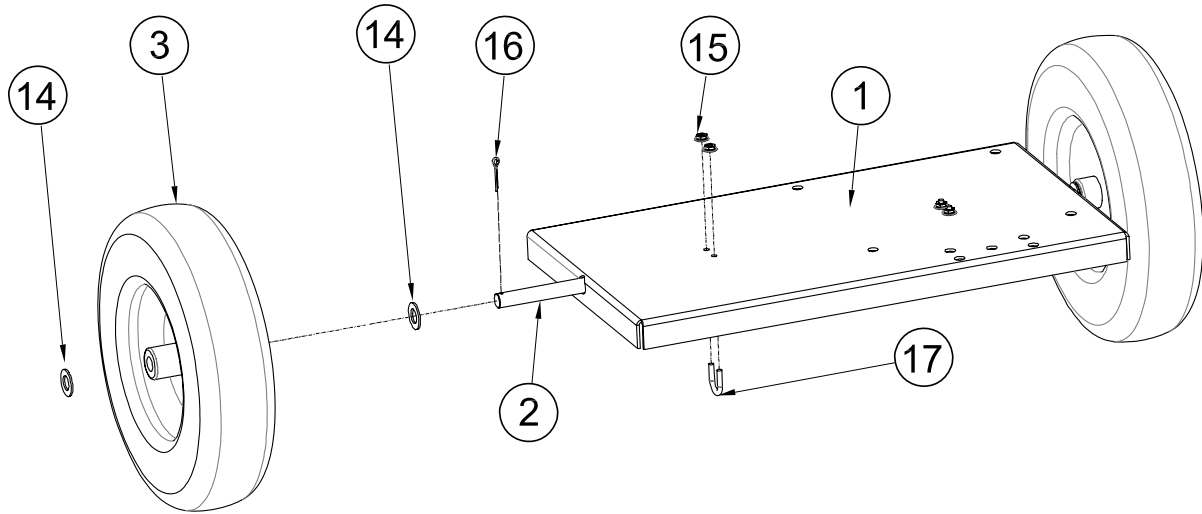

STEP 4

- Place the generator on the base and mount using the hardware provided (ref. 9, 11, 12). Apply decal (ref. 18) to base. Grease wheel bearings as needed.

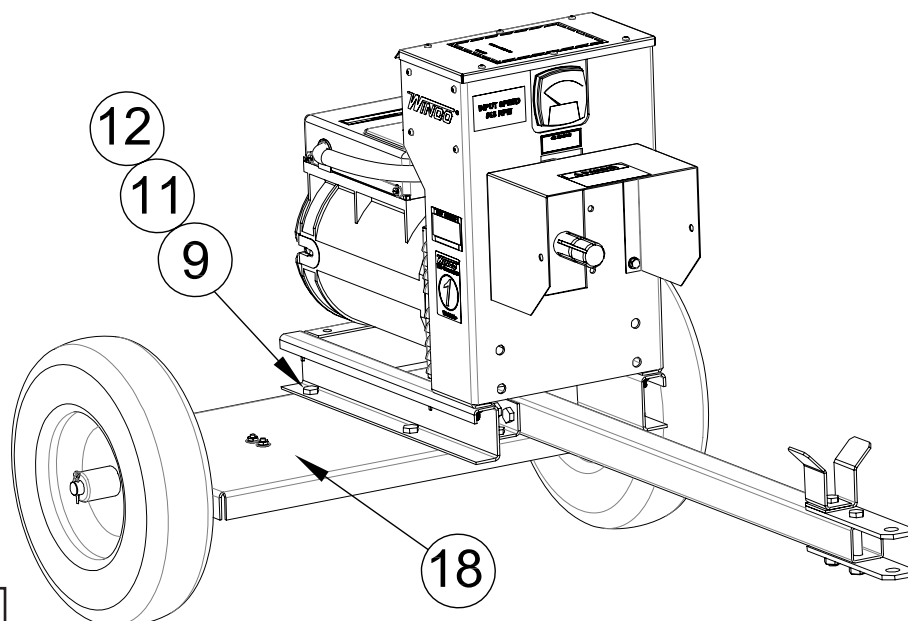

Winco Inc.
Service Dept.
507-357-6831