

# HONDA Engine Model Number: GC160

This information has been extracted out of the Honda engine operators manual No. 31ZL8601 00X31-ZL8-6010 For additional information see the complete Honda Manual.

## MAINTENANCE SCHEDULE

ITEM	REGULAR SERVICE PERIOD (1)		Before use	First month or 5 Hrs.	Every season or 25 Hrs.	Every season or 50 Hrs.	Every 100 Hrs.	Every 150 Hrs.	Refer to page	
	Perform at every indicated month or operating hour interval, whichever comes first.									
• Engine oil	Check		○						25	
	Change			○		○ (3)			26	
• Air filter	Check		○						29	
	Clean				○ (2)					
	Replace							○ (200 Hrs.)	30	
• Spark plug	Check-Clean						○		31	
	Replace							○ (200 Hrs.)		
• Spark arrester (optional part)	Clean						○		33	
• Fuel tank and filter	Clean						○ (4)		—	
• Idle speed	Check-Adjust							○ (4)	—	
• Valve clearance	Check-Adjust							○ (4)	—	
• Fuel line	Check	Every 2 years (Replace if necessary) (4)								—

## ENGINE OIL RECOMMENDATIONS

Oil is a major factor affecting performance and service life. Use 4-stroke automotive detergent oil.

SAE 10W-30 is recommended for general use. Other viscosities shown in the chart may be used when the average temperature in your area is within the recommended range.

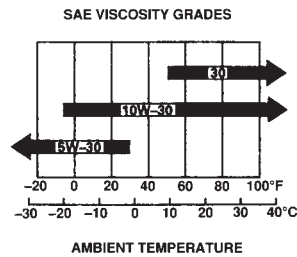

The SAE oil viscosity and service classification are in the API label on the oil container. Honda recommends that you use API SERVICE category SF or SG

## ENGINE OIL LEVEL CHECK

Check the engine oil level with the engine stopped and in a level position.

1. Remove the oil filler cap/dipstick and wipe it clean.
2. Insert and remove the dipstick without screwing it into the filler neck. Check the oil level shown on the dipstick.
3. If the oil level is low, fill to the edge of the oil filler hole with the recommended oil (see page 28).
4. Reinstall the oil filler cap.

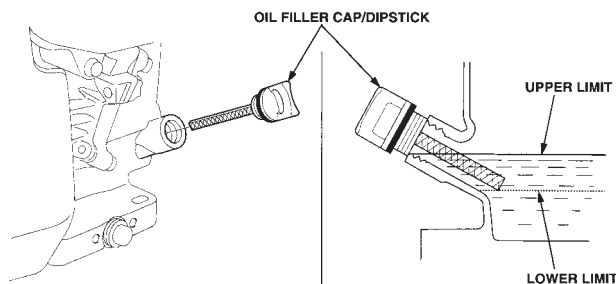

## ENGINE OIL CHANGE

Drain the used oil while the engine is warm. Warm oil drains quickly and completely.

1. Place a suitable container below the engine to catch the used oil, then remove the oil filler cap/dipstick and the drain plug.
2. Allow the used oil to drain completely, then reinstall the drain plug, and tighten it securely.

Please dispose of used motor oil in a manner that is compatible with the environment. We suggest you take used oil in a sealed container to your local recycling center or service station for reclamation. Do not throw it in the trash, pour it on the ground, or down a drain.

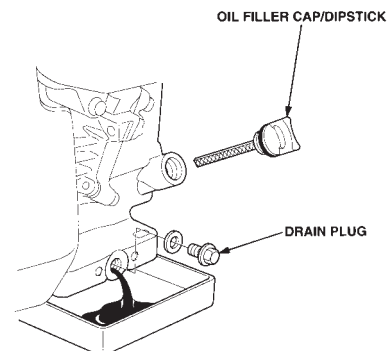

3. With the engine in a level position, fill to the outer edge of the oil filler hole with the recommended oil (see page 28).

Engine oil capacity: 0.61 US qt (0.58 ℓ)

### NOTICE

Running the engine with a low oil level can cause engine damage.

The Oil Alert system (applicable engine types) will automatically stop the engine before the oil level falls below the safe limit. However, to avoid the inconvenience of an unexpected shutdown, fill to the upper limit, and check the oil level regularly.

4. Screw in the oil filler cap/dipstick securely.

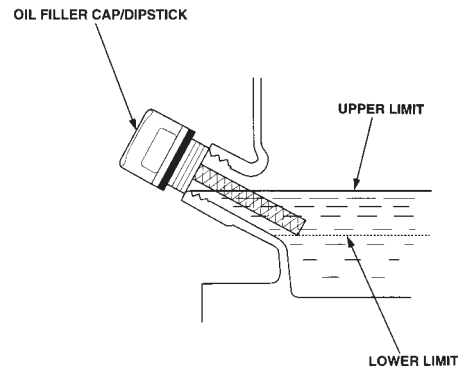

### NOTICE

Running the engine with a low oil level can cause engine damage.

The Oil Alert system (applicable engine types) will automatically stop the engine before the oil level falls below safe limits. However, to avoid the inconvenience of an unexpected shutdown, always check the engine oil level before startup.

# HONDA Engine Model Number: GC160

## REFUELING

### Fuel tank capacity

GC135: 0.45 US gal (1.7 ℓ)

GC160: 0.53 US gal (2.0 ℓ)

With the engine stopped, remove the fuel tank cap and check the fuel level. Refill the tank if the fuel level is low.

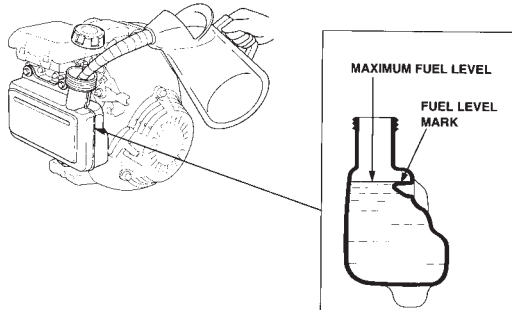

Refuel in a well-ventilated area before starting the engine. If the engine has been running, allow it to cool. Refuel carefully to avoid spilling fuel. Do not fill above the fuel level mark. After refueling, tighten the fuel tank cap securely.

Never refuel the engine inside a building where gasoline fumes may reach flames or sparks. Keep gasoline away from appliance pilot lights, barbecues, electric appliances, power tools, etc.

Spilled fuel is not only a fire hazard, it causes environmental damage. Wipe up spills immediately.

### NOTICE

Fuel can damage paint and plastic. Be careful not to spill fuel when filling your fuel tank. Damage caused by spilled fuel is not covered under warranty.

## FUEL RECOMMENDATIONS

Use unleaded gasoline with a pump octane rating of 86 or higher.

These engines are certified to operate on unleaded gasoline. Unleaded gasoline produces fewer engine and spark plug deposits and extends exhaust system life.

Never use stale or contaminated gasoline or an oil/gasoline mixture. Avoid getting dirt or water in the fuel tank.

Occasionally you may hear a light “spark knock” or “pinging” (metallic rapping noise) while operating under heavy loads. This is no cause for concern.

If spark knock or pinging occurs at a steady engine speed, under normal load, change brands of gasoline. If spark knock or pinging persists, see an authorized Honda servicing dealer.

### NOTICE

Running the engine with persistent spark knock or pinging can cause engine damage.

Running the engine with persistent spark knock or pinging is misuse, and the Distributor's Limited Warranty does not cover parts damaged by misuse.

## AIR FILTER INSPECTION

Press the latch tabs on the fuel tank side of the air cleaner cover, and remove the cover. Check the filter to be sure it is clean and in good condition.

If the filter is dirty, clean it as described on page 30. Replace the filter if it is damaged.

Reinstall the filter and air cleaner cover.

### NOTICE

Operating the engine without an air filter, or with a damaged air filter, will allow dirt to enter the engine, causing rapid engine wear. This type of damage is not covered by the Distributor's Limited Warranty.

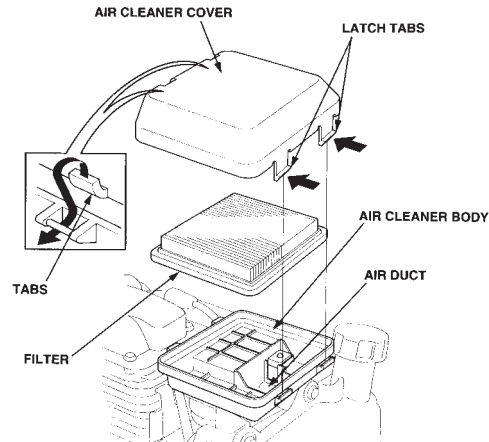

## SPARK PLUG SERVICE

Recommended spark plug: BPR6ES (NGK)

### NOTICE

An incorrect spark plug can cause engine damage.

1. Disconnect the spark plug cap, and remove any dirt from around the spark plug area.
2. Remove the spark plug with a 13/16-inch spark plug wrench.

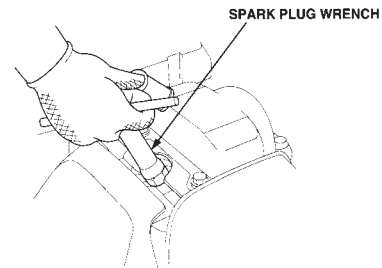

3. Inspect the spark plug. Replace it if the electrodes are worn, or if the insulator is cracked or chipped. Clean the spark plug with a wire brush if you are going to reuse it.

4. Measure the spark plug electrode gap with a suitable gauge. The gap should be 0.028—0.031 in (0.70—0.80 mm). Correct the gap, if necessary, by carefully bending the side electrode.

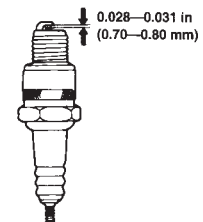

5. Install the spark plug carefully, by hand, to avoid cross-threading.
6. After the spark plug seats, tighten with a 13/16-inch spark plug wrench to compress the washer.

If reinstalling the used spark plug, tighten 1/8—1/4 turn after the spark plug seats.

If installing a new spark plug, tighten 1/2 turn after the spark plug seats.

### NOTICE

A loose spark plug can overheat and damage the engine. Overtightening the spark plug can damage the threads in the cylinder head.

7. Attach the spark plug cap.