

ILLUSTRATED PARTS LIST

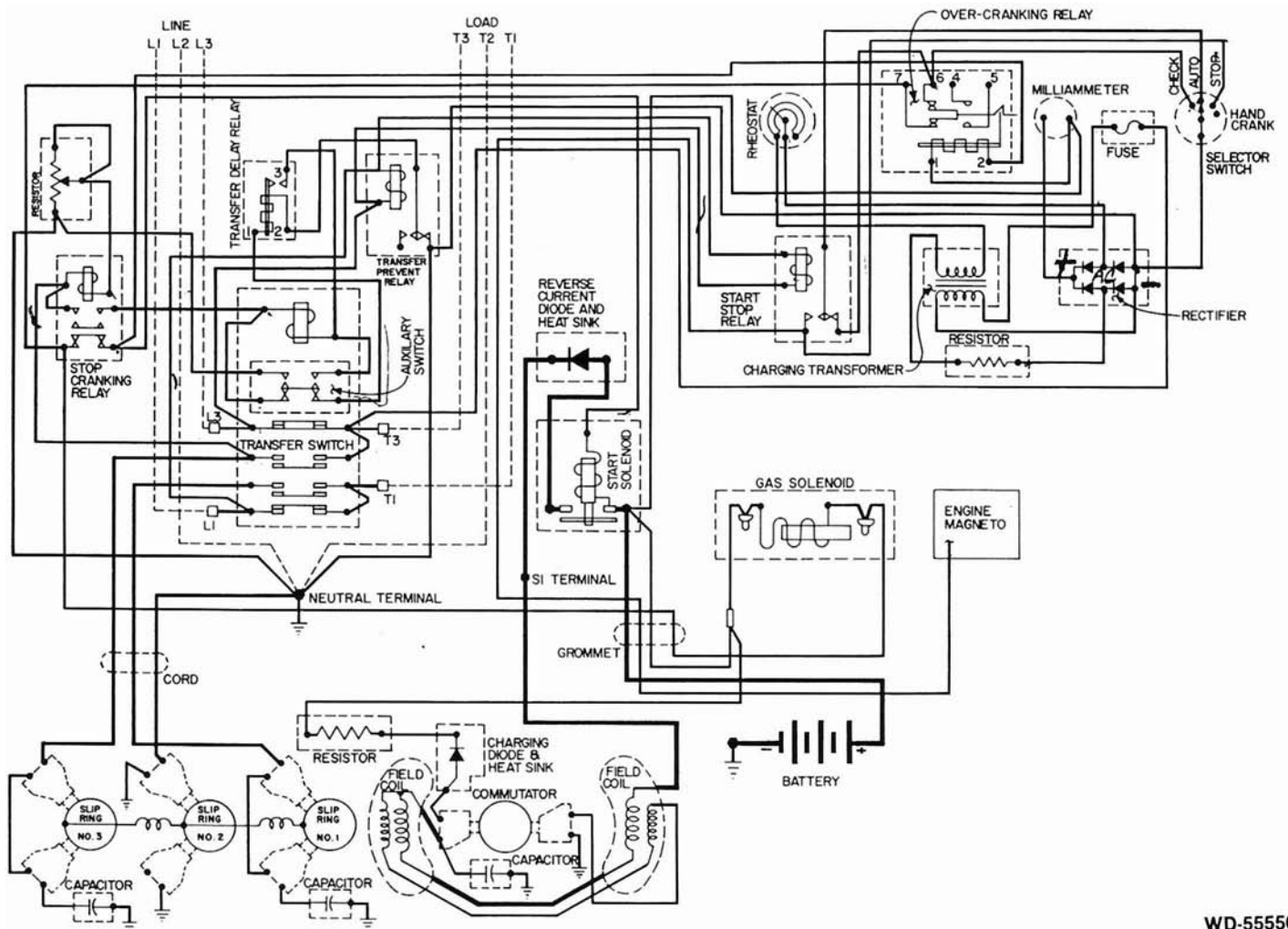

WD-55550

SCHEMATIC DIAGRAM

This IPL contains wiring, illustration, parts list, ordering information and technical data to perform routine maintenance on this generator. Consult factory with model no., serial no. and test data for further assistance.

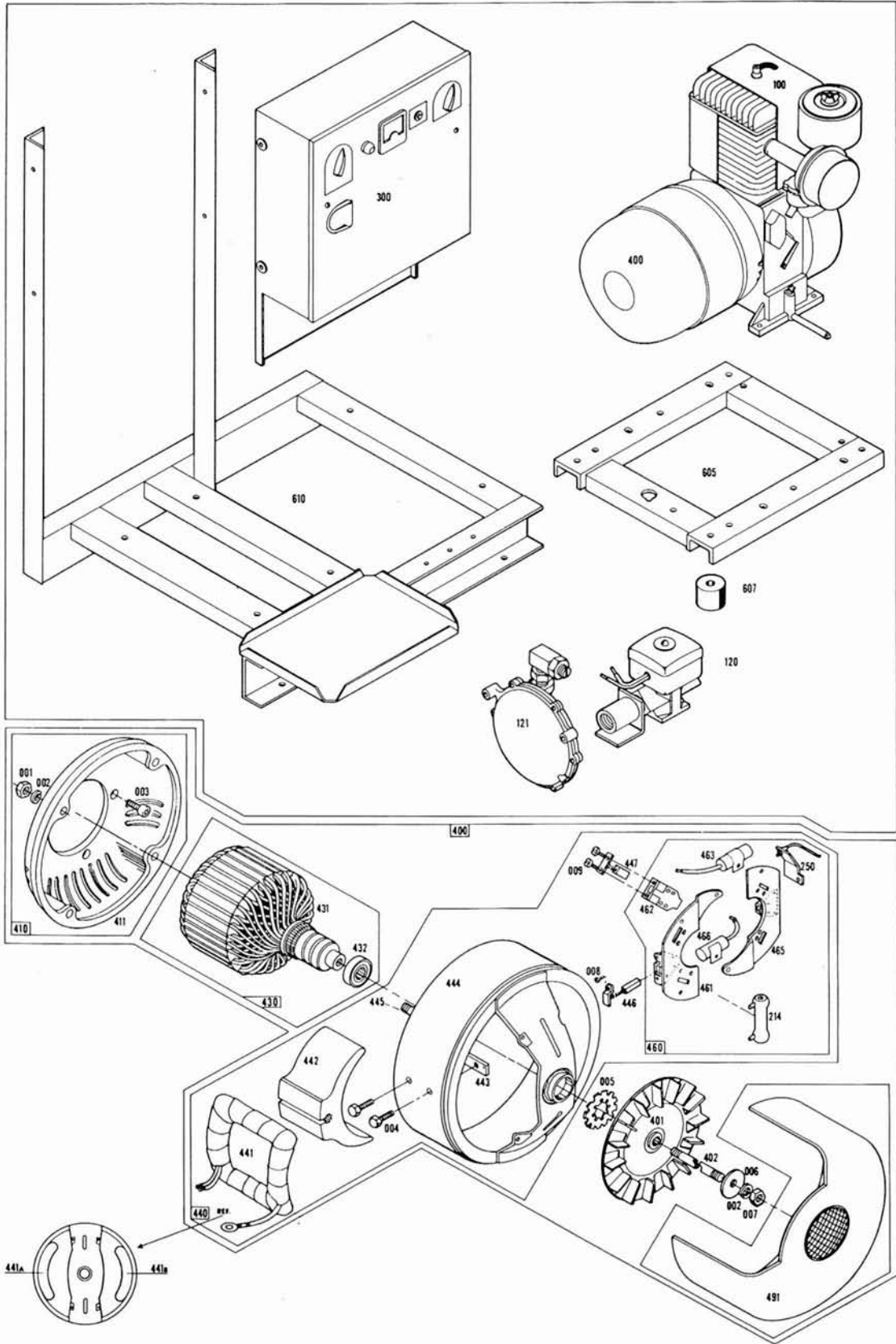

REF. NO.	DESCRIPTION	QTY.	PART NO.	REF. NO.	DESCRIPTION	QTY.	PART NO.
000	Hardware						
001	Nut 5/16-18	4	458	441A	Field Coil	1	55422
002	Lockwasher Split 5/16	5	480	441B	Field Coil	1	55422-1
003	Cap Screw	4	3290	442	Pole Shoe	2	23207
004	Cap Screw	4	9416	443	Pole Shoe Retainer	2	23208
005	Lockwasher	1	55224	444	Field Shell and Bracket	1	55417
006	Flatwasher 11/32 ID	1	23558	445	Stud	4	23451
007	Nut 5/16-24	1	23605	446	Brush DC	2	41393
008	Screw 10-24 x 3/8	3	4637	447	Brush AC	6	23607
009	Screw 8-32 x 5/16	12	40746	460	Brush Rack Assembly	1	55423
100	Drive B & S 252411 02919-01	1	59158	214	Resistor <i>DS</i>	1	41984
120	Solenoid (Fuel shut off)	1	42942	250	Heat Sink and Diode Ass'y.	1	15047-
121	Regulator (Secondary)	1	55559	461	Riveted Brush Rack Ass'y.	1	41744
123	Load Block	1	55560	462	Brush Holder	6	23500
				463	Capacitor AC	2	41221
				465	Riveted Brush Rack	1	41744-1
400	Generator Assembly	1	58380-2	466	Capacitor DC	1	41180
401	Fan Assembly	1	55101	491	End Cover	1	55438-6
402	Special Shaft	1	23197-7				
411	End Bracket	1	54178	605	Sub Frame Assembly	1	57963
430	Armature Assembly	1	55317	607	Shock Mount	8	20191
431	Armature	1	55317-1	610	Main Frame	1	58977
432	Bearing	1	55223	—	Flexible exhaust line	1	24140-2
440	Field Shell & Coil Ass'y.	1	55421		(not shown)		

002

PARTS ORDERING INFORMATION REQUIRED

To fill your order for service parts, please advise the complete Generator model number and serial number, part number(s), and part description. If in doubt, consult the factory prior to placing the order. Send all parts orders to WINCO, Division of Dyna Technology, Inc., 225 South Cordova Ave., Le Center, MN 56057.



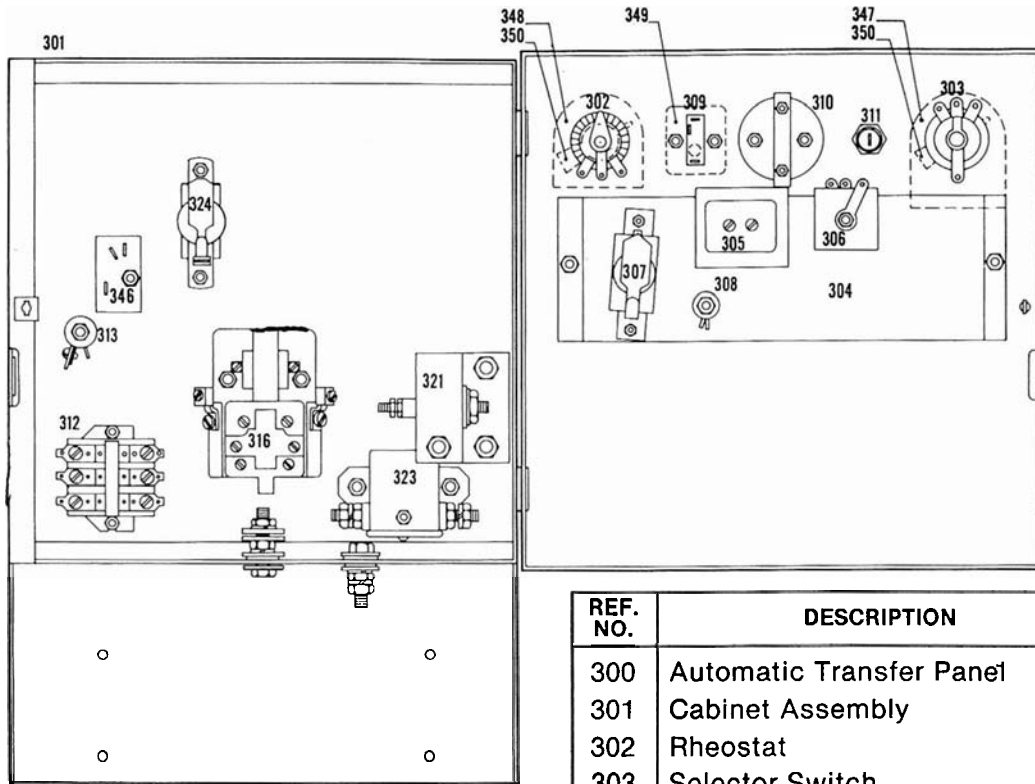

I-59155

TECHNICAL DATA

GENERATOR SPECIFICATIONS:

Watts—5000 Volts—115/230 Amps.—21.7
PH-1; Hz-60; RPM—3600

Nominal Voltage: No Load: Full Load:
115/230 Volts A.C. 132/264 Volts A.C. 112/224 Volts A.C.

Resistance:

Field Coils— $2.2 \pm .12$ ohms
Armature—Less than 1 ohm ring to ring

Excitation Voltage:

Approximately 28 Volts D.C.

Separately Excited:

12 VDC to the Positive Field Lead
50 to 70 VAC Output

REF. NO.	DESCRIPTION	QTY.	PART NO.
300	Automatic Transfer Panel	1	59155
301	Cabinet Assembly	1	59235
302	Rheostat	1	24786
303	Selector Switch	1	57946
304	Mounting Bracket	1	59240
305	Transformer	1	46755
306	Rectifier	1	91452-000
307	Relay (start/stop)	1	59944-006
308	Resistor	1	24787
309	Relay (over cranking)	1	48585
310	Milliammeter	1	22188
311	Fuse holder	1	2489
311A	Fuse 250V IA 3AG	1	22219
312	Relay (stop cranking)	1	59944-015
313	Resistor	1	23635
316	Contact Switch Kit (30 A contacts)	1	64573-003
321	Heat Sink and Rectifier	1	51060-000
323	Start Solenoid	1	24061
324	Relay (transfer prevent)	1	59944-006
346	Thermal Delay Relay	1	48525
347	Selector Switch Dial Plate	1	21962
348	Rheostat Dial Plate	1	8777
349	Instruction Plate	1	53324
350	Knob	2	8778
—	Auxiliary Contact Kit for Contactor Sw. (not shown)	1	46759

WINGO®

Division of
DYNA TECHNOLOGY, INC.
225 South Cordova
Le Center, MN 56057
Phone (612) 357-6821
Telex 290753