

### ILLUSTRATED PARTS LISTS

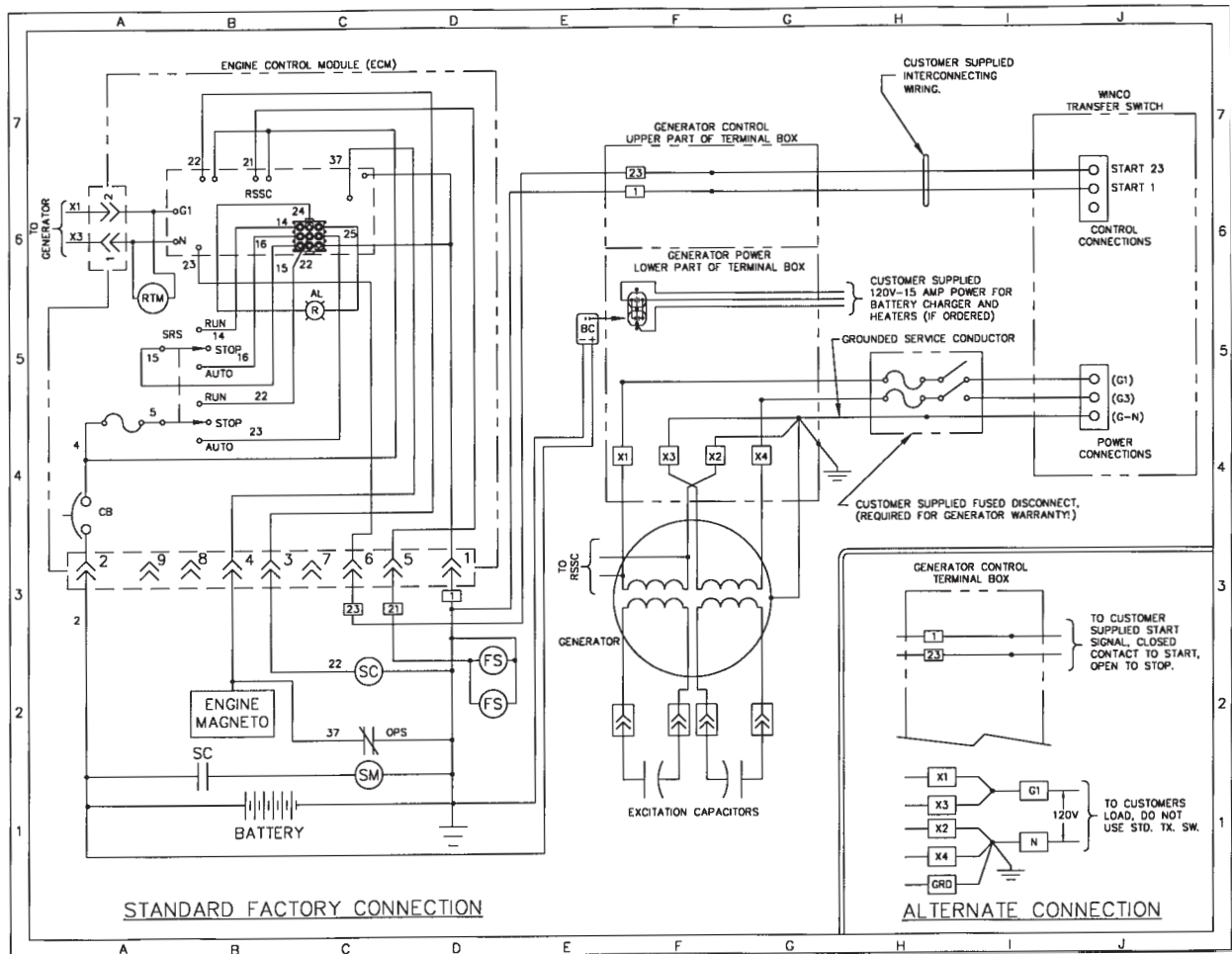

### LEGEND

AL	ALARM LAMP
BC	BATTERY CHARGER
CB	CIRCUIT BREAKER
FS	FUEL SOLENOID
G1, G3 & G-N	GENERATOR LEAD IDENTIFICATION
X1, X2, X3 & X4	GENERATOR PHASE LEADS
N	NEUTRAL
RSSC	REMOTE START STOP CONTROL MODULE
SC	STARTER MOTOR CONTACTOR
SM	STARTER MOTOR
SRS	AUTO-STOP-RUN SWITCH
RTM	RUNNING TIME METER

## AC AND DC GENERATOR SCHEMATIC

# ENGINE GENERATOR ASSEMBLY

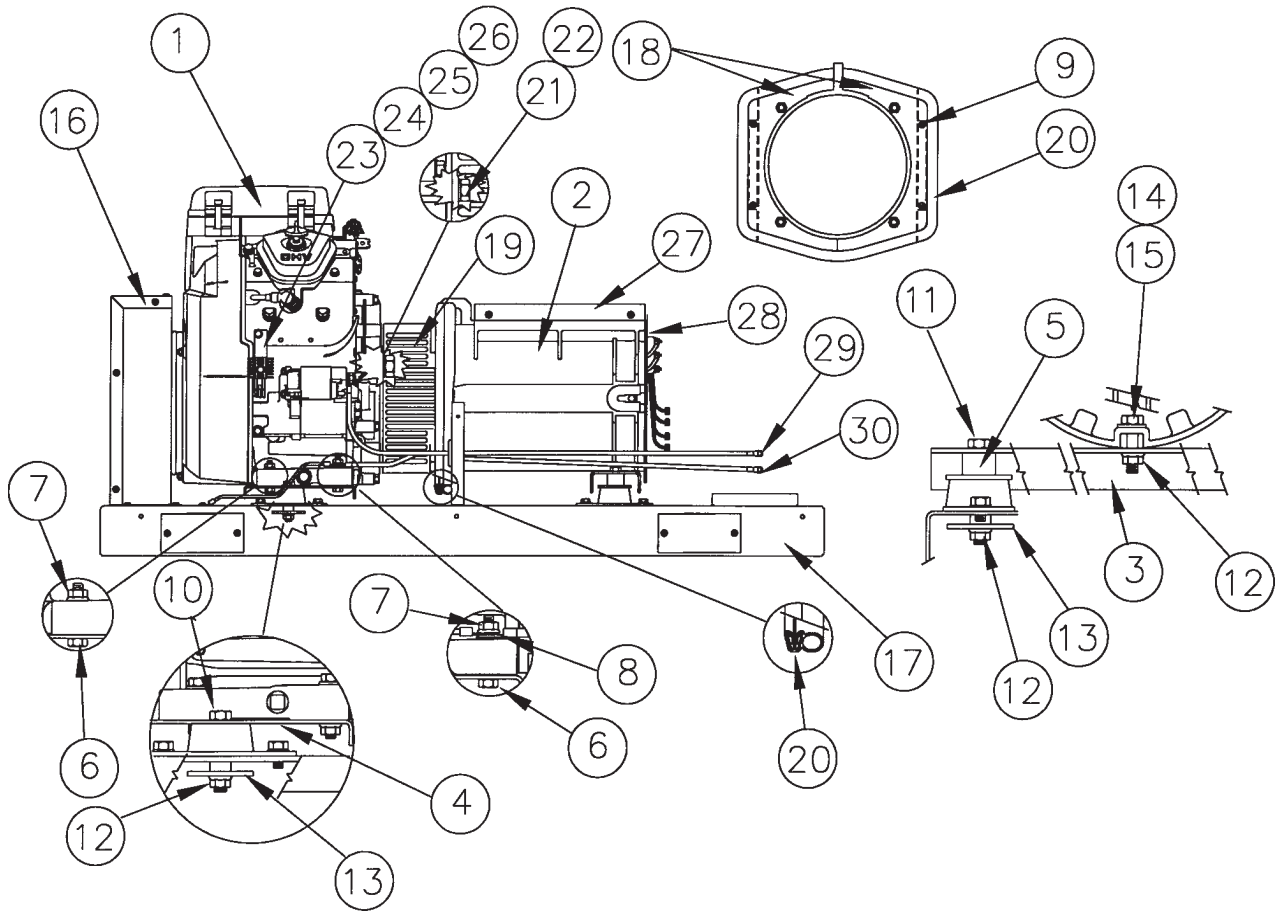

REF	Description	QTY	PSS10	PSS12
1	Engine, Honda GX620K1VXC2 Code 637220 GX670VXC2 Code 637220	1	99779-000	99780-000
2	Generator	1	300323-1	300323-2
3	Generator Shockmount Support	1	300275-11	300275-11
4	Engine Shockmount Support	1	300250-13	300250-14
5	Spacers	2	300040-1	300040-1
6	5/16-18 X 1-1/2 Hex Head Bolt	4	468-000	468-000
7	5/16-18 Hex Flange Nuts	4	16249-000	16249-000
8	5/16 Flat Washer	2	526-000	526-000
9	#10 X 3/8 Self Tapping Screw	18	21698-001	21698-001
10	3/8-16 X 2-1/2 Hex Head Bolt	2	91658-007	91658-007
11	3/8-16 X 3-1/2 Hex Head Bolt	2	91658-014	91658-014
12	3/8-16 Hex Flange Nut	5	16250-000	16250-000
13	3/8 ID X 2" Flat Washer	6	98806-000	98806-000
14	3/8-16 X1-1/4 Hex Head Bolt	1	91658-002	91658-002
15	3/8 Flat Washer	1	8472-000	8472-000
16	Air Inlet Cover	1	300405-2	300405-2
17	Base Assembly	1	300384-13	300384-13
18	Generator Air Baffle	2	64587-001	64587-001
19	Generator Heat Shield Side Panel	2	64857-006	64857-006
20	Air Seal 37 Inches	1	16338-002	16338-002
21	3/8-16 X 1 Grade 5 Hex Head Bolt	4	91658-001	91658-001

REF	Description	QTY	PSS10	PSS12
22	3/8 Split Lockwasher	4	481-000	481-000
23	Bat. Charging Rectifier Mtg Brkt	1	51788-001	51788-001
24	M6 X 1.00 Hex Flange Nut	4	64841-001	64841-001
25	M6 X 1.00 X 12 MM Hex Head Bolt	1	75139-012	75139-012
26	¼ Split Lockwasher	1	479-000	479-000
27	Generator Cover	1	300322-410	300322-410
28	Terminal Box Adapter	1	300330-410	300330-410
29	Battery Cable Positive	1	15767-011	15767-011
30	Battery Cable Negative	1	15767-007	15767-007

## ENGINE GENERATOR BASE ASSEMBLY

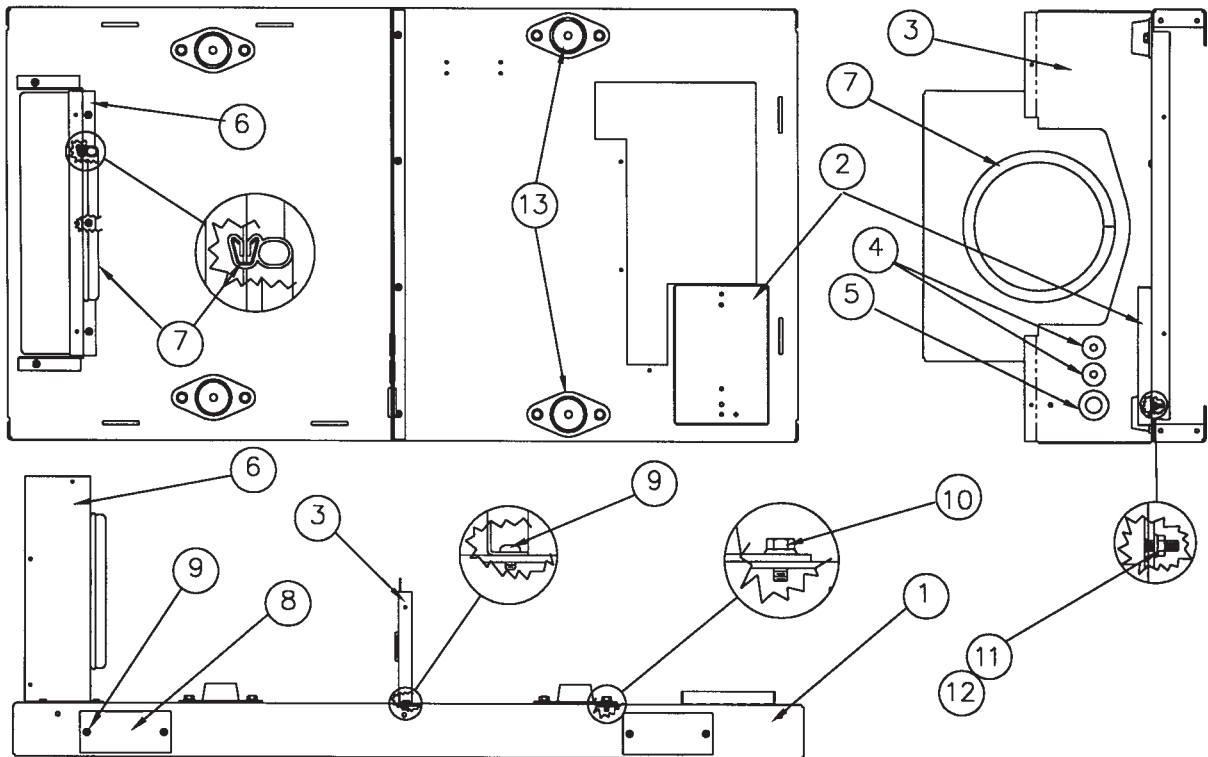

REF	Part Number	QTY	Description
1	3000376-2	1	Base
2	15676-000	1	Battery Tray
3	64857-002	1	Engine Partition Bottom Panel
4	23917-002	2	Grommet
5	16302-000	1	Grommet
6	300404-5	1	Engine Air Inlet Adapter
7	16338-003	1	Air Seal 25.5"
8	300274-14	4	Lifting Hole Cover Plate
9	21698-001	17	#10 X 3/8 Self Tapping Screw
10	55440-000	8	¼ X 20 X 1/2 Hex Head Self Tapping Screw
11	95568-000	2	#10 - 24 X ½ Thread Stud
12	99671-000	2	#10 - 24 Hex Flange Nut
13	98807-000	4	Shockmount

## AC & DC ELECTRICAL WIRING

REF	Part Number	QTY	Description
1	64630-001	1	Spacer Channel
2	16294-401	1	Engine Control Module
3	300354-1	1	AC Wiring Harness
4	300352-003	1	DC Wiring Harness
5	300323-113	1	Terminal Block
7	91658-003	1	3/8 – 16 X 1 1/2 Hex Head Bolt
8	16250-000	1	3/8 – 16 Flange Nut
9	8472-000	1	3/8 Flat Washer
10	300278-3	1	Terminal Box Half
11	300321-1	1	Terminal Box Cover
12	300309-11	1	Terminal Box Divider
13	300278-4	1	Terminal Box Half
14	24749-000	1	Receptacle
15	16287-000	1	Battery Charger
16	300308-1	1	Battery Charger Hold Down
17	16302-000	1	Grommet
18	21698-001	24	#10 X 3/8 Self Tapping Screw
19	48042-000	2	Ground Lug
20	476-000	1	1/4 – 20 X 5/8 Hex Head Bolt
21	16248-000	1	1/4 - 20 Hex Flange Nut
22	23917-000	1	Grommet

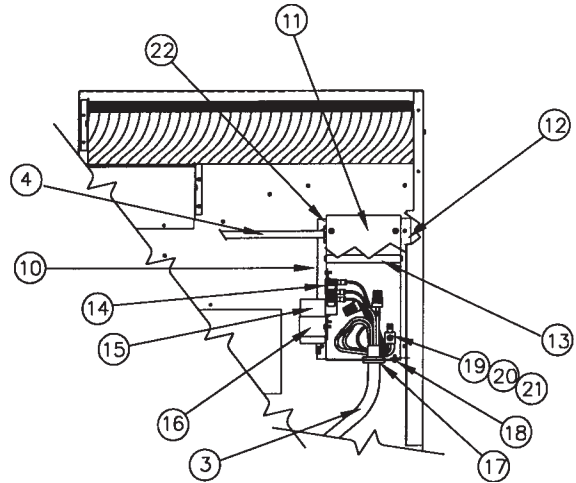

BLACK CAPACITOR LEADS  
RED CAPACITOR LEADS

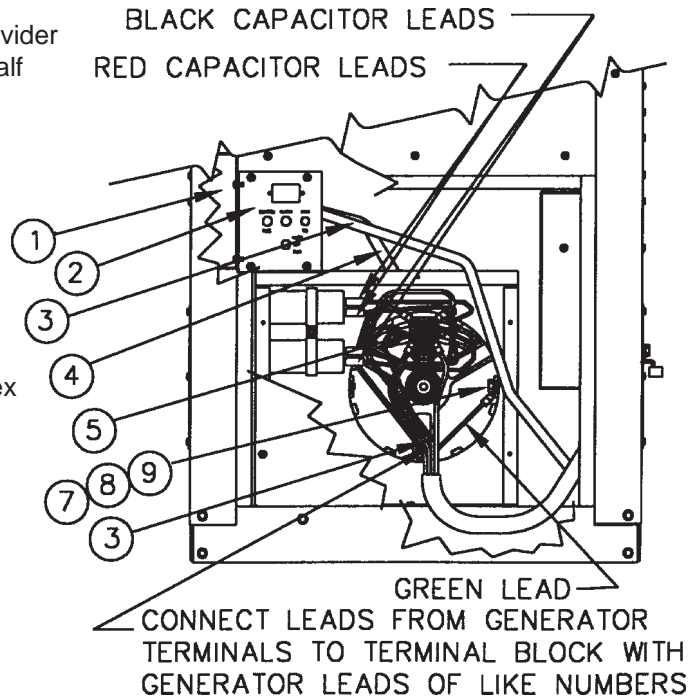

## ENGINE OIL DRAIN

REF	Part Number	QTY	Description
1	300349	1	Oil Drain Valve
2	300349-1	1	Oil drain Adapter M12 X 1.5 to 3/8"
3	62286-001	1	1 1/2" I.D. Neoprene Hose 12"
4	62999-004	1	Hose Clamp
5	62825-001	1	Tubular Split Spacer
6	64616-070	1	M6 X 1.0 X70MM Socket Head Cap Screw
7	479-000	1	1/4" Split Lockwasher
8	96187-000	1	Oil Drain Gasket

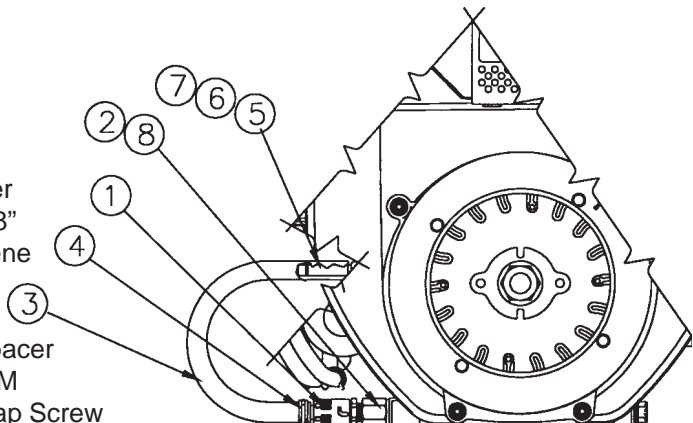

## LP/NG FUEL SYSTEM

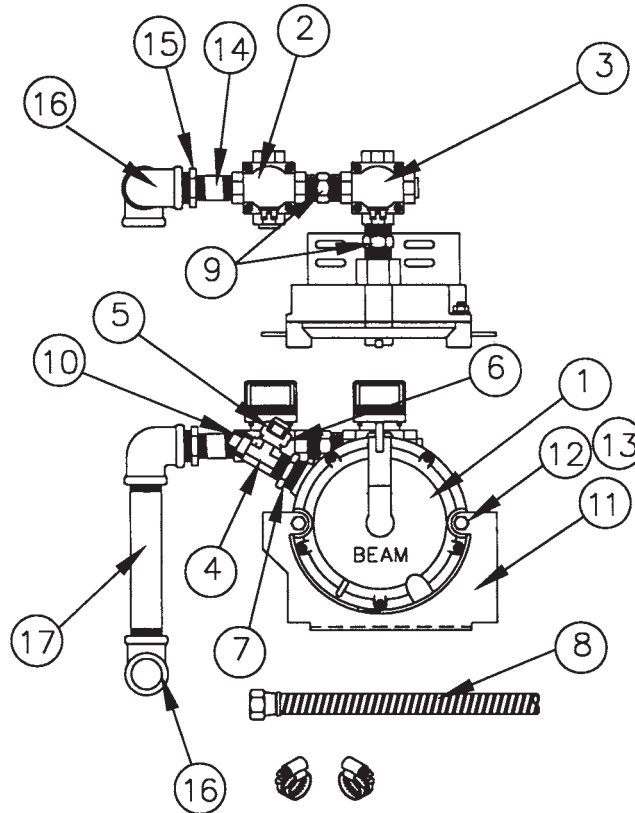

REF #	Part Number	QTY	Description
1	T202ANL-E*	1	Regulator
2	FL-30639*	1	Solenoid
3	FL-30638*	1	Solenoid
4	F4-30637*	1	Tee Fitting
5	J1-30655-002*	1	Orifice Insert 5.4mm LP
6	C2-30035*	1	Cap Nut ½ SAE Flare
7	F4-30635*	1	Fitting ¾ NPT X ½ NPT Bushing
8	AH1-30634*	1	Fuel Hose ½ X 40" with ½ Female Flare Fitting & Clamp
9	F4-30633*	2	Fitting ½ Hex Nipple
10	J1-30655-003*	1	Orifice Insert 6.7mm NG
11	16332-000	1	Mounting Bracket
12	1679-000	2	¼ - 20 X 1 ½ Hex Head Bolt
13	16248-000	2	¼ - 20 Flange Nut
14	21089-000	1	½" X 1 ½" Pipe Nipple
15	81075-000	1	¾ to ½ Hex Pipe Reducer
16	50244-000	2	¾ 90 Degree Elbows
17	54074-000	1	¾" X 5 ½" Pipe Nipple

\* These are IMPCO Carburetion, Inc. part numbers. These parts are only available as a kit from WINCO, Inc. The PSS10H kit is P/N 16331-001 and the PSS12H kit is P/N 16331-002.

## ENCLOSURE ASSEMBLY

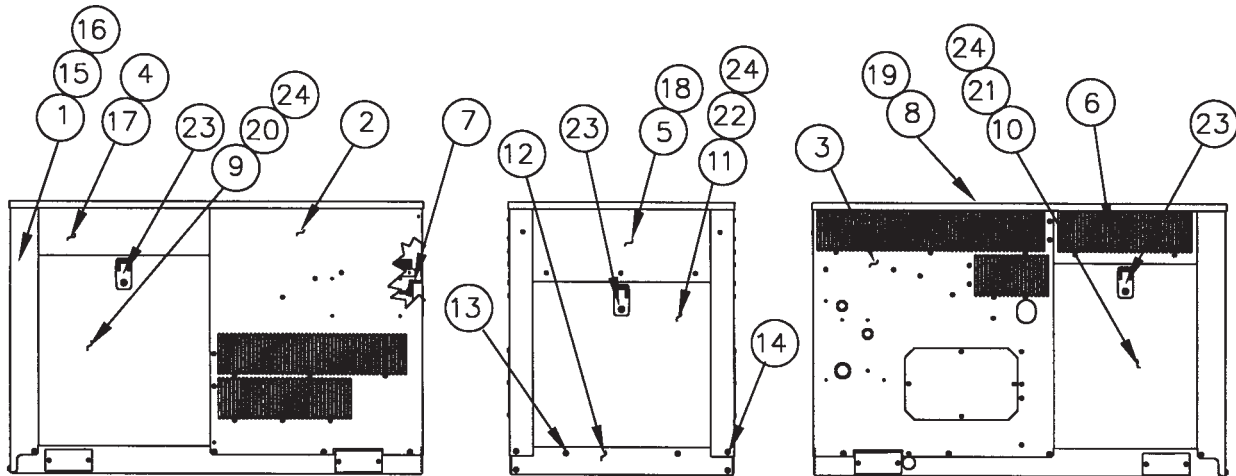

REF	Part Number	QTY	Description
1	64736-001	1	Housing Front Panel
2	16334-001	REF	Housing Left Side Panel
3	16334-002	REF	Housing Right Side Panel
4	300411-6	1	Left Door Top Panel
5	300411-8	1	Rear Door Top Panel
6	16334-005	REF	Right Door Top Panel
7	16334-006	REF	Engine Partition Assembly
8	15677-001	1	Roof Panel
9	300418-5	1	Left Door
10	300418-3	1	Right Door
11	300418-2	1	Rear Door
12	300378-01	1	Lower Rear Panel
13	55440-000	8	¼-20 X ½ Hex Head Self Tapping Screw
14	21698-001	85	#10 x 3/8 Self Tapping Screws
15	99788-014	1	Foam Insulation Front Panel
16	99788-016	1	Foam Insulation Front Panel
17	99788-023	1	Foam Insulation Left Door Top Panel
18	99788-024	1	Foam Insulation Rear Door Top Panel
19	99788-030	1	Foam Insulation Roof Panel
20	99788-033	1	Foam Insulation Left Door
21	99788-034	1	Foam Insulation Right Door
22	99788-035	1	Foam Insulation Rear Door
23	95229-005	3	Door Latch
24	62912-000	19.5	Neoprene Strip for Doors (ft)

### 16334-005 - RIGHT DOOR TOP PANEL

REF	Part Number	QTY	Description
1	300411-7	1	Right Side Door Top Panel
2	300318-5	1	Air Baffle
3	99788-025	1	Foam Insulation
4	21698-001	8	#10 X 3/8 Self Tapping Screw

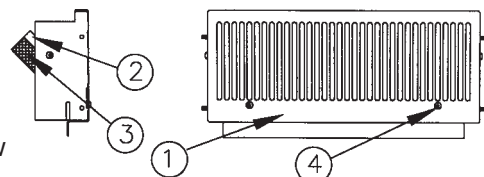

### 16334-001 - LEFT SIDE PANEL

REF	Part Number	QTY	Description
1	15664-001	1	Left Side Panel
2	99788-017	1	Foam Insulation
3	99788-018	1	Foam Insulation
4	99788-019	1	Foam Insulation
5	99788-020	1	Foam Insulation
6	3000318-2	1	Air Baffle
7	300318-1	1	Air Baffle
8	300317-4	1	Louver End Piece
9	300317-6	1	Louver End Piece
10	21698-001	21	#10 X 3/8 Self Tapping Screw
11	55440-000	3	¼ - 20 X ½ Hex Head Self Tapping Screw

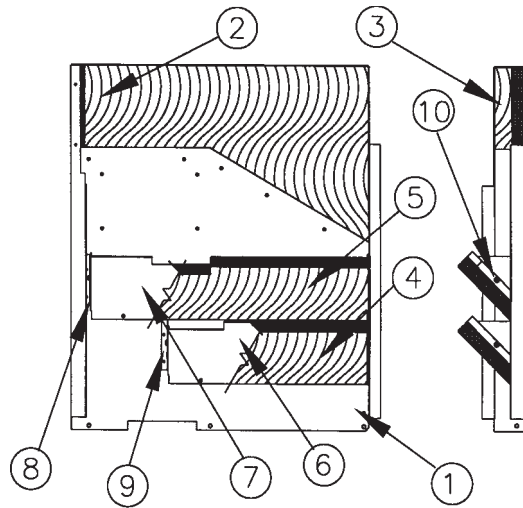

### 16334-002 - RIGHT SIDE PANEL

REF	Part Number	QTY	Description
1	15665-001	1	Right Side Panel
2	99788-021	1	Foam Insulation
3	99788-022	1	Foam Insulation
4	300274-11	1	Cover Plate
5	300318-3	1	Air Baffle
6	300318-4	1	Air Baffle
7	300317-4	1	Louver End Piece
8	300317-3	1	Louver End Piece
9	300317-5	1	Louver End Piece
10	21698-001	26	#10 X 3/8 Self Tapping Screw
11	55440-000	3	¼ - 20 X ½ Hex Head Self Tapping Screw
12	95586-001	2	#10 - 24 X ½ Thread Stud
13	99671-000	2	#10 - 24 Hex Flange Nut

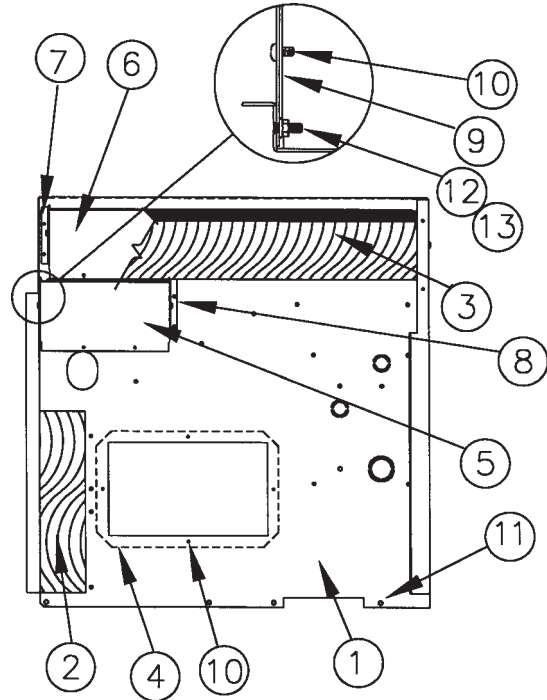

### 16334-006 - ENGINE PARTITION ASSEMBLY

REF	Part Number	QTY	Description
1	64857-004	1	Engine Partition Panel
2	99788-026	1	Foam Insulation
3	99788-027	1	Foam Insulation
4	99788-028	1	Foam Insulation
5	21698-001	2	#10 X 3/8 Self Tapping Screw
6	16302-000	1	Grommet

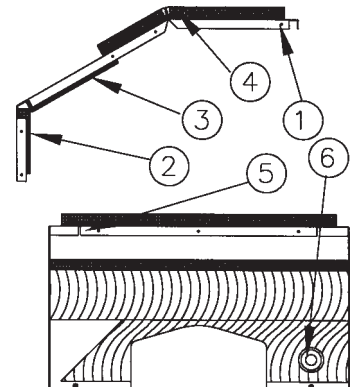

## DECAL INSTALLATION

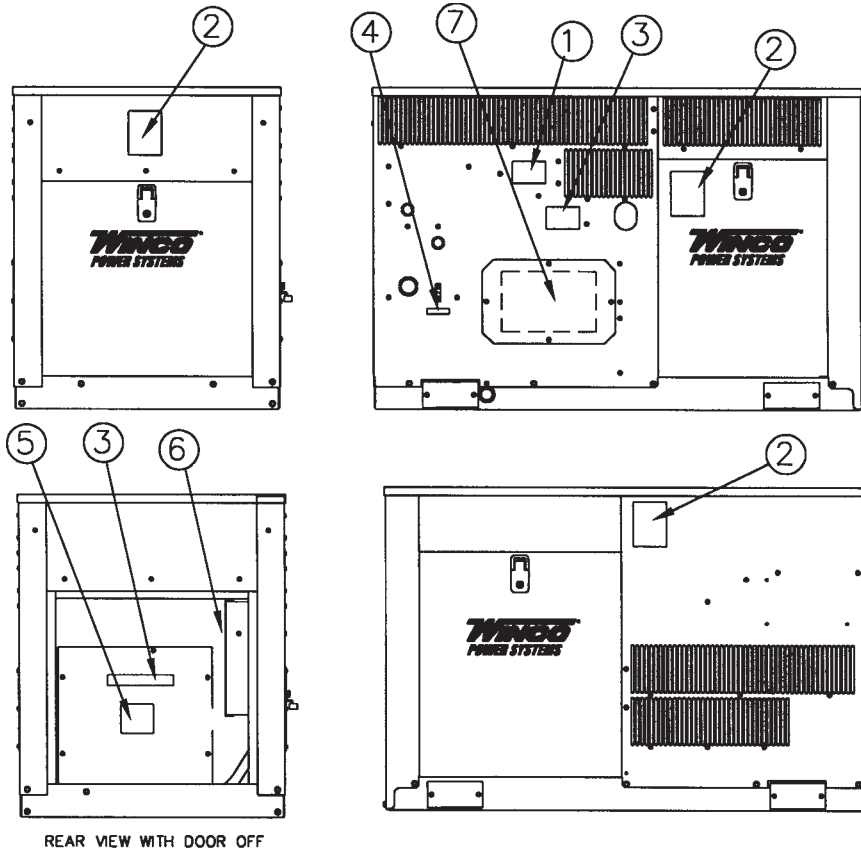

REAR VIEW WITH DOOR OFF

REF	Part Number	QTY	Description
1	63941-001	1	Hot Surface Decal
2	97813-000	1	Automatic Start Decal
3	15209-000	1	Safety Decal Set
4	15750-001	1	Ground Decal
5	63966-003	1	Nameplate
6	15768-004	1	Connection Decal
7	97338-005	1	Fuel Change-Over Decal

## MUFFLER & HEAT SHIELD

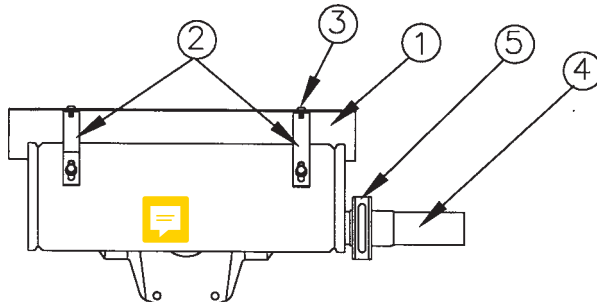

REF	Part Number	QTY	Description
1	300296-2	1	Heat Shield
2	51788-002	2	Heat Shield Bracket
3	21698-001	2	#10 X 3/8 Self Tapping Screw
4	99316-002	1	Exhaust Pipe
5	93489-015	1	Exhaust Clamp
NI	16237-001	1	Spark Arrestor Kit





## GENERATOR ASSEMBLY

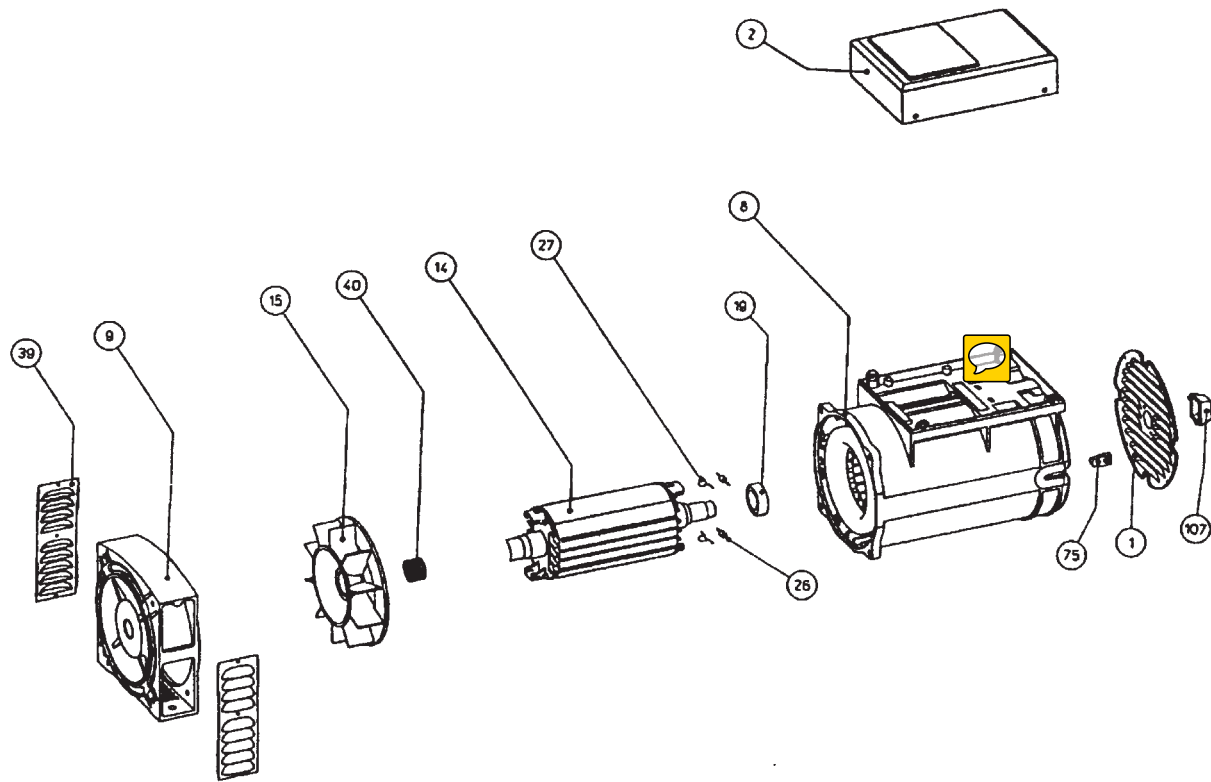

REF	PSS10H/B	QTY	DESCRIPTION	PSS12H/A
1	300330-410	1	Terminal Box Adapter	300330-410
2	300322-410	1	Generator Cover	300322-410
8	300323-103	1	Stator	300323-203
9	300323-104	1	Engine Bracket	300323-204
14	300323-105	1	Rotor	300323-205
15	300323-106	1	Fan	300323-206
19	54665-000	1	Bearing	54665-000
26	300323-107	1	Diode	300323-207
27	300323-108	1	Varistor	300323-208
39	64857-006	2	Protection Screen	64857-006
40	300323-110	1	Tolerance Ring	300323-210
107	300323-111	1	Rubber Cap	300323-211

# OUTLINE DRAWING

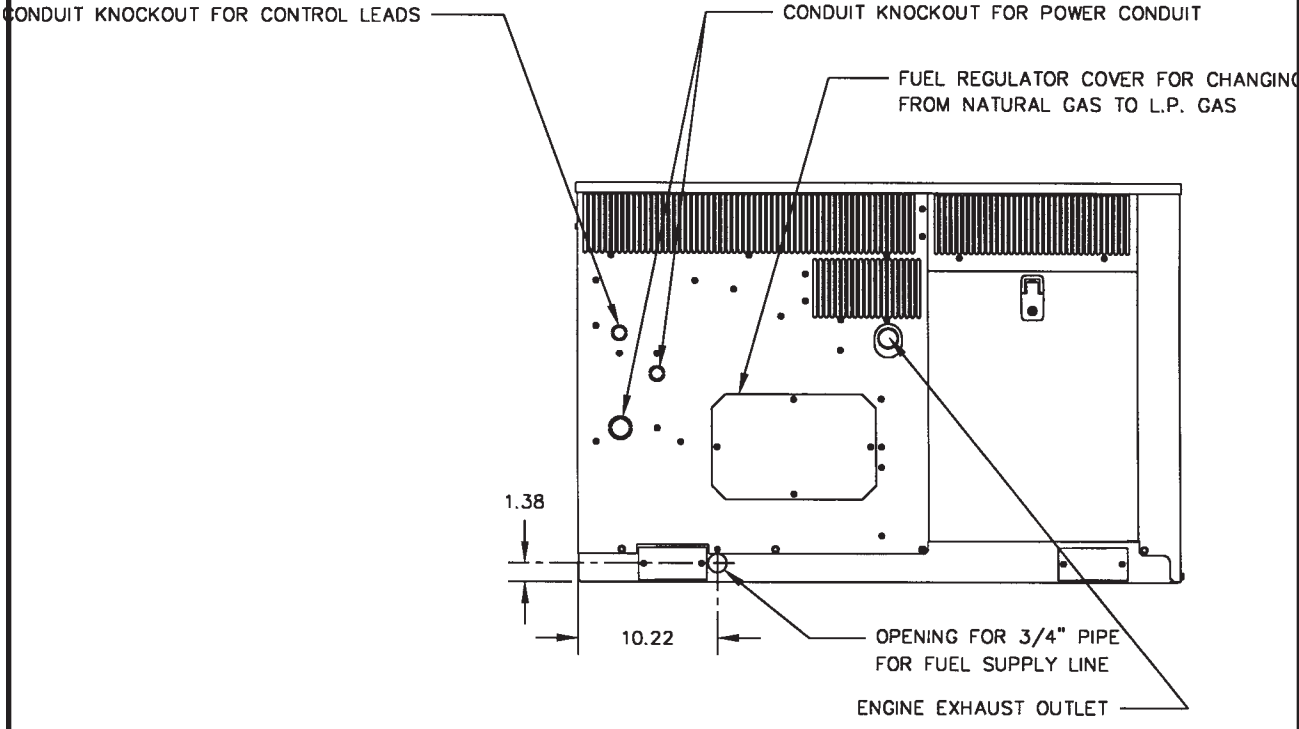
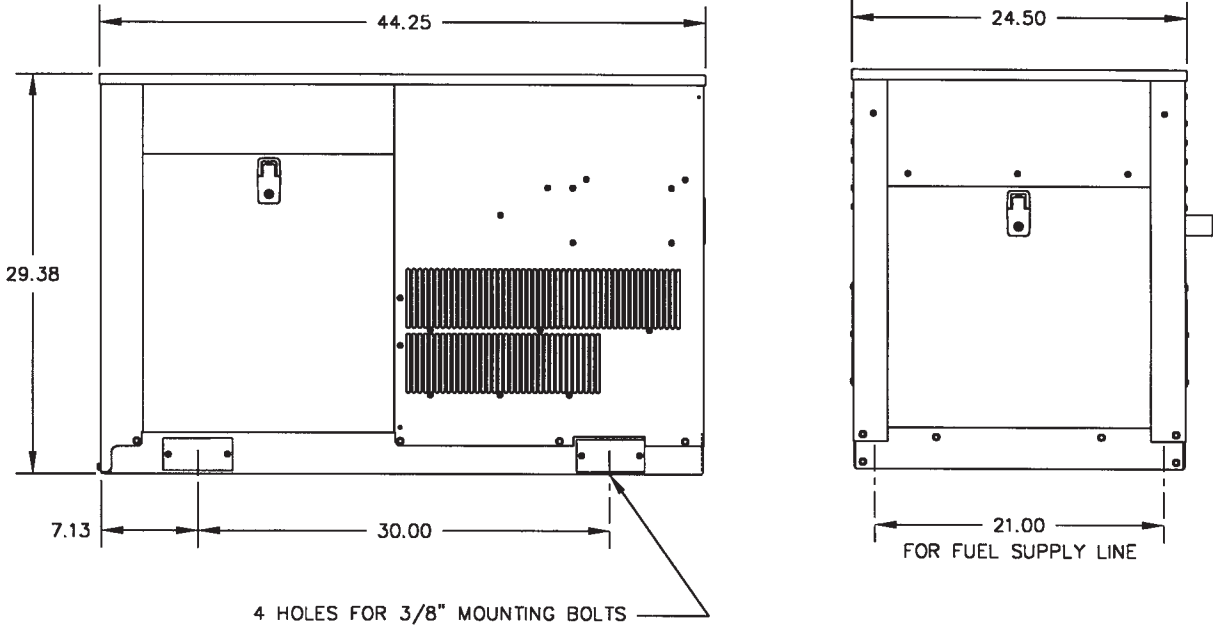

# NOTES

P/N 60701-134 - 3064-10

**WINGO INC**<sup>®</sup>  
A Division of **DTE** Dyna Technology Inc  
225 South Cordova Avenue  
Le Center MN 56057  
507-357-6831  
[www.wincogen.com](http://www.wincogen.com)