

GR LEGEND - B=BAT C=CONT. E=ENG. F=FUEL G=GEN.  
 (GROUP) H=HOUSING R=RADIATOR Z=MISC.  
 SHD15000-4R/A, -17R/A

GR	DESCRIPTION	PART #	/--< 3PH >--\		
			< -4R QTY. >	< -17R QTY. >	
1 B*	BAT. CABLE ASY 1GA (NEG)	53220-040	1	1	1
2 B*	BAT. CABLE ASY 1GA (POS)	53220-039	1	1	2
3 B*	BATTERY - 12VGP21 650CCA	60765-004	1	1	3
4 B*	BATTERY MTG. BRKT.	96166-000	1	1	4
5 B*	HOLD DOWN BRACKET	96718-000	1	1	5
6 B*	HOLD DOWN ROD	96717-000	2	2	6
7					7
8 C*	CIR.BRK. 15A-1PL-12VDC	94387-402	1	1	8
9 C*	CIR.BRK.15A-1PL	91286-000	1	1	9
10 C*	CIR.BRK.40A-3PL-240V	58483-006	1	--	10
11 C*	CIR.BRK.35A-3PL-240V	58483-002	--	1	11
12 C*	CIR.BRK.70A-2PL-240V	57030-006	1	--	12
13 C*	CIR.BRK.60A-2PL-240V	57030-005	--	1	13
14 C*	CONTROL PANEL ASSY. -4R	97415-404	1	--	14
15 C*	CONTROL PANEL ASSY.-17R	97415-402	--	1	15
16 C*	D.C. VOLTMETER	94395-000	1	1	16
17 C*	ENGINE CONT PREWIRE	95689-002	1	1	17
18 C*	FUEL GAUGE	95648-000	1	1	18
19 C*	GLOW PLUG INDICATOR	96578-002	1	1	19
20 C*	GROUND STRAP ASSY.	95231-001	1	1	20
21 C*	LAMP 14V BULB (PANEL)	94988-000	1	1	21
22 C*	LAMP HOLDER (PANEL)	94987-000	1	1	22
23 C*	LAMP 14V (INDICATOR)	94983-000	10	10	23
24 C*	LAMP SOCKET	94982-000	5	5	24
25 C	LENS-HIGH COOL TEMP (R)	94984-007	1	1	25
26 C	LENS-LOW OIL PRESS (R)	94984-002	1	1	26
27 C	LENS-OVERSPEED (R)	94984-001	1	1	27
28 C	LENS-OVERCRANK (R)	94986-004	1	1	28
29 C	LENS-PREHEAT (Y)	94985-006	1	1	29
30 C*	OIL PRESSURE GAUGE	94396-000	1	1	30
31 C*	WATER TEMP. GAUGE	94397-000	1	1	31
32 C	PERIPHERAL SEAL	96927-004	1	1	32
33 C*	RECEPT NEMA 5-15R	24749-000	1	1	33
34 C*	TERMINAL BLOCK-POWER	51795-000	1	1	34
35 C*	TERMINAL BLOCK-CONTROL	22148-000	1	1	35
36 C	RECEPT. CONNECTOR	96925-003	1	1	36
37 C*	RELAY-PRI 120 VAC SPDT	59944-001	1	1	37
38 C*	RUNNING TIME METER	58166-006	1	1	38
39 C*	LAMP TEST SWITCH-SP MOM	94388-404	1	1	39
40 C*	PANEL LIGHT SWITCH-SPST	94388-402	1	1	40
41 C*	START/AUTO SWITCH-DPDT	94388-401	1	1	41
42 C*	START SOLENOID 12VDC	80980-000	1	1	42
43 C*	SPECIAL GLOW SOLENOID	80601-000	1	1	43
44 C*	DIODE - GLOW SOLENOID	45876-000	1	1	44
45					45

A121B.  
72190-411

GR LEGEND - B=BAT C=CONT. E=ENG. F=FUEL G=GEN.  
 (GROUP) H=HOUSING R=RADIATOR Z=MISC.  
 SHD15000-4R/A, -17R/A

GR	DESCRIPTION	PART #	/ - < 3PH > - \		
			< -4R QTY. >	< -17R QTY. >	
46 E*	AIR FILTER & ELEMENT	97275-001	1	1	46
47 E*	BANJO BOLT 12M1.25	97432-000	1	1	47
48 E*	BANJO UNION	97431-000	1	1	48
49 E*	BREATHER PIPE ASSY.	97440-000	1	1	49
50 E	DC WIRING HARNESS	97273-401	1	1	50
51 E*	DRIVE DISK	96377-000	2	2	51
52 E	EL-HOS.ADPT.1/8X1/4	56879-000	2	2	52
53 E*	ENG-KUBOTA VH-1100	96578-001	1	1	53
54 E*	EXHAUST PIPE WELD	97270-001	1	1	54
55 E*	FLYWHEEL HOUSING	96066-000	1	1	55
56 E	HALF COUPL. 1-1/4	97259-000	1	1	56
57 E	HOSE- 1.25ID RB	81103-000	1	1	57
58 E	HX.RED.BUSH.3/8X1/2	56372-000	1	1	58
59 E	MP FIT. 1/4-18NP	91747-000	1	1	59
60 E	MTG. BRACKET, AIR CLNR.	93484-007	2	2	60
61 E*	MUFFLER WELDMENT	97438-000	1	1	61
62 E*	OIL PRESSURE SWTICH	72254-002	1	1	62
63 E*	RESTRICTION GAUGE	97279-000	1	1	63
64 E*	VOLTAGE REG. 12V	96577-005	1	1	64
65 E*	WATER TEMP. SW. MOD.	72255-004	1	1	65
66					66
67 F*	ELECTRIC FUEL PUMP	81332-001	1	1	67
68 F	FILLER NECK	97250-002	1	1	68
69 F*	FUEL FILTER	97303-000	1	1	69
70 F*	FUEL SOLENOID MOD.	97302-400	1	1	70
71 F*	FUEL TANK 21.5 GAL	96118-000	1	1	71
72 F	HOSE- 1/4ID RB (FT)	40078-000	6	6	72
73 F	SENDER, FUEL LEVEL	98433-000	1	1	73
74					74
75 G*	ARM/HUB ASSY. (-4) 3PH	63850-001	1	--	75
76 G*	ARM/HUB ASSY. (-17) 3PH	63850-003	--	1	76
77 G*	ARM/HUB ASSY. (-517) 3PH	63850-004	--	**	77
78 G*	BR HLDR & RACK ASSY -3PH	63940-001	1	1	78
79 G*	BR HLDR & RACK ASSY -3PH	63940-000	1	1	79
80 G*	BRUSH ASSY. - AC	24981-000	16	16	80
81 G*	BRUSH HLDR MTG PLATE	53975-000	6	6	81
82 G*	BRUSH HOLDER SPACER	52559-000			82
83 G*	BRUSH HOLDER - AC	23500-402	16	16	83
84 G*	CAPACITOR ASSY.	41221-000	3	3	84
85 G*	END COVER ASSY	55438-015	1	1	85
86 G*	FAN ASSY.	23404-000	1	1	86
87 G*	FIBER SPACER	23532-000	16	16	87
88 G*	FIELD COIL ASSY. -LEFT	63938-000	1	1	88
89 G*	FIELD COIL ASSY. -RIGHT	63938-001	1	1	89
90 G*	FLD RING & BRKT ASY	97288-000	1	1	90

GR LEGEND - B=BAT C=CONT. E=ENG. F=FUEL G=GEN.  
 (GROUP) H=HOUSING R=RADIATOR Z=MISC.  
 SHD15000-4R/A, -17R/A

GR	DESCRIPTION	PART #	/ - < 3PH > - \		
			< -4R QTY. >	< -17R QTY. >	
91	G* FLD SHL & COIL ASSY	63939-000	1	1	91
92	G* NOTCHED BEARING	59062-000	1	1	92
93	G* POLE SHOE ASSY 8"	43473-000	2	2	93
94	G* POLE SHOE RETAINER	63937-000	2	2	94
95	G* RECTIFIER	91452-000	1	1	95
96	G* SLIP RING - 2 RINGS	50742-000	2	2	96
97					97
98	H* ANGLE CLIP	97233-000	1	1	98
99	H* BASE WELDMENT	96153-000	1	1	99
100	H* CONTROL COVER WELD	96570-000	1	1	100
101	H* CONTROL PANEL HINGE	96576-000	1	1	101
102	H* CONTROL PANEL WELD	96574-000	1	1	102
103	H* ENGINE MOUNT WELD	96182-000	2	2	103
104	H* ENG/GEN BASE WELD	96158-000	1	1	104
105	H HOUSING WELD. -ENG END	96475-000	1	1	105
106	H* GEN MOUNT WELD	96370-000	2	2	106
107	H* GRILL WELDMENT	96766-000	1	1	107
108	H* LOWER SIDE COVER (L)	96517-000	1	1	108
109	H* LIFTING CHANNEL WELD	96642-000	1	1	109
110	H* LIFTING ROD	96648-000	2	2	110
111	H* PROP ROD WELD - STRAIGHT	97228-000	1	1	111
112	H* PROP ROD WELD - BENT	97232-000	1	1	112
113	H* REAR LOWER COVER ASY	96569-000	1	1	113
114	H* CONTROL MTG PANEL	96790-000	1	1	114
115	H* HOUSING WELD. -GEN END	96550-000	1	1	115
116	H* LOWER SIDE COVER (R)	96516-000	1	1	116
117	H* ROOF ASSY.	97446-400	1	1	117
118	H* SERVICE DOOR ASSY.	97445-400	1	1	118
119	H* SHOCKMOUNT	97260-000	4	4	119
120	H* SIDE DOOR ASSY.	97444-400	1	1	120
121					121
122	R BRACKET, COOLANT BTL	94339-000	1	1	122
123	R COLLANT RECOVERY	94338-000	1	1	123
124	R ENG WIRING HARNESS	97334-001	1	1	124
125	R FAN GUARD WELD	96843-000	1	1	125
126	R FAN SHROUD	96511-000	1	1	126
127	R* FAN SPACER	95854-001	1	1	127
128	R* LWR.HOSE PIPE ADPT.	97267-000	1	1	128
129	R* RADIATOR	97250-001	1	1	129
130	R RADIATOR MOUNT	96769-000	2	2	130
131	R RAD.HOS.1.5IDX1.5ID	92979-018	1	1	131
132	R UPR.RAD.HOSE 1.5ID	93372-000	1	1	132
133					133
134	Z DECAL - REMOTE OP. INST.	97338-002	1	1	134
135	Z DECAL - ENGINE SERVICE	97334-000	1	1	135

GR LEGEND - B=BAT C=CONT. E=ENG. F=FUEL G=GEN.  
 (GROUP) H=HOUSING R=RADIATOR Z=MISC.

SHD15000-4R/A, -17R/A

GR	DESCRIPTION	PART #	/--< 3PH >--\		
			< -4R QTY. >	< -17R QTY. >	
136					136
137 Z*	COMPLETE UNIT ASSEMBLY	97561-004	1	--	137
138 Z*	COMPLETE UNIT ASSEMBLY	97561-002	--	1	138
139 **	ENGINE OPERATOR'S MANUAL	96578-003	1	1	139
140 **	UNIT OPERATOR'S MANUAL	60706-059	1	1	140
141 **	REPAIR PARTS LIST	60701-072	1	1	141

	KUBOTA P/N	ENERGX #
OIL FILTER	15241-32099	N/A
AIR FILTER	>>>----->	97275-0XX
FUEL FILTER ASSY	>>>----->	97303-000
5 MICRON ELEMENT	>>>----->	97303-001
10 MICRON ELEMENT	>>>----->	97303-011

	SHD15000-4R/A	SHD15000-17R/A
COMPLETE UNIT	- 97651-004	97561-002
DC SCHEMATIC	- 97422-001	97422-001
AC WIRING	- 97415-004	97415-002
DC WIRING	- 97815-000	97815-000
CONTROL PANEL	- 97815-002	97815-000
CONTROL BOX	- 97560-005	97560-002
ENG GEN SET	- 97263-003	97263-001
BR.RACK WIRING	- 63849-007	63849-005

AC RESIDUAL VOLTS	7.0 VAC L-L	7.0 VAC L-L
AC OUT- 12VDC	200 VAC L-L	200 VAC L-L
FIELD RESISTANCE	26.5 OHMS	26.5 OHMS
WINDING SPEC. (SS#)	1511	1512
ARM. CONNECTION (AC#)	133	362

467

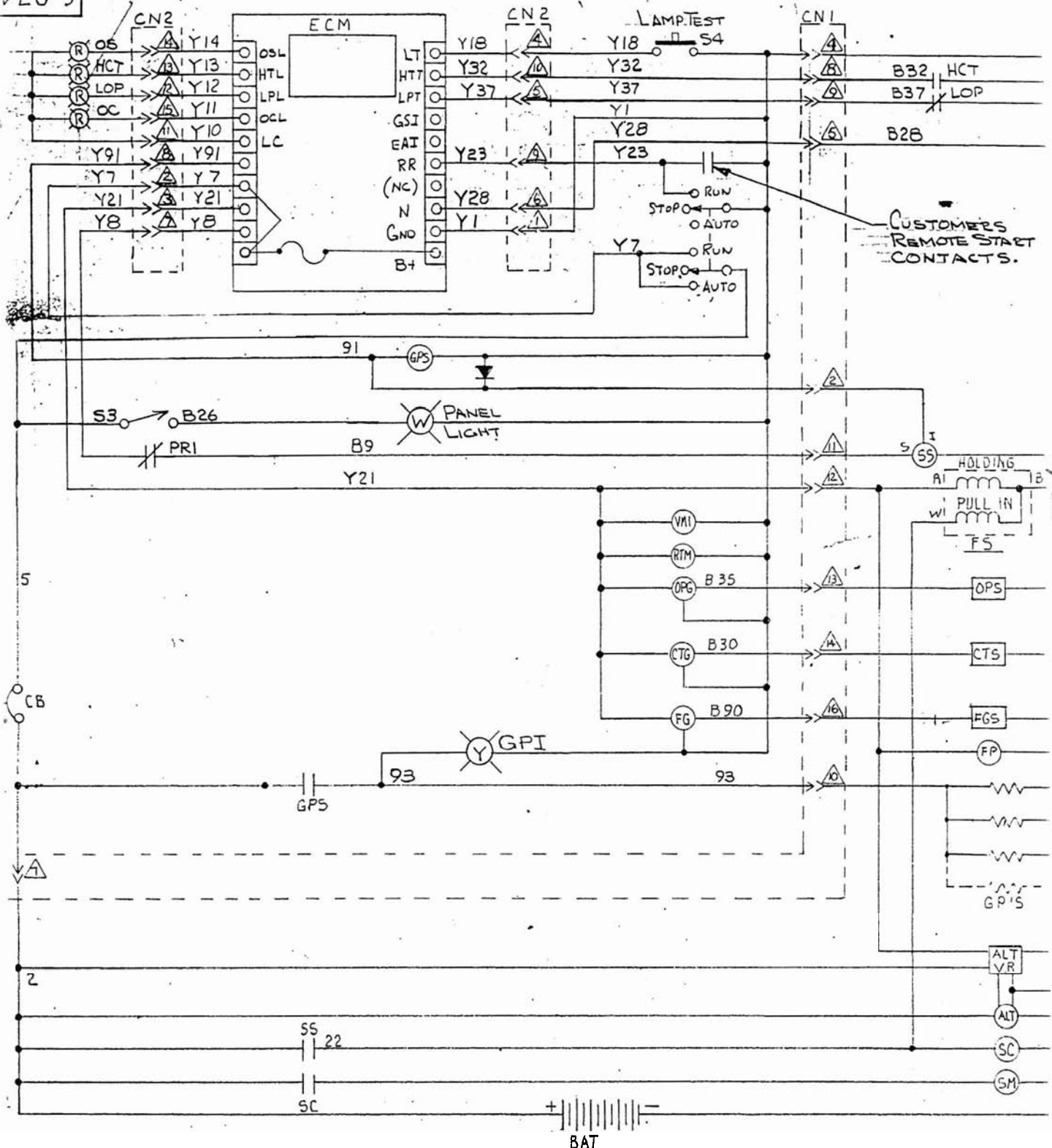

97422-1  
SHD 15000-4R/A  
-17R/A

**LEGEND**

ALT	ALTERNATOR	FS	FUEL RACK SOLENOID	RC	RECEPTACE
ALT-VR	ALTERNATOR VOLTAGE REGULATOR	GND	GROUND	RTM	RUNNING TIME
BAT	BATTERY	GP'S	GLOW PLUGS	SI	SWITCH
CB	CIRCUIT BREAKER	GPI	GLOW PLUG INDICATOR	SC	START CONTACT
CR	CONTROL RELAY	GPS	GLOW PLUG SOLENOID	SM	STARTING MOTOR
CTG	COOLANT TEMPERATURE GAUGE	HCT	HIGH COOLANT TEMPERATURE	SN	SYSTEMS NO
CTS	COOLANT TEMPERATURE SENDER	LOP	LOW OIL PRESSURE SWITCH	SS	START SOLENOID
ETS	ETHER TEMPERATURE SWITCH	OPG	OIL PRESSURE GAUGE	TD	TIME DELAY
FG	FUEL GAUGE	OPS	OIL PRESSURE SENDER	VM	VOLT METER
FGS	FUEL GAUGE SENDER	OS	OVER SPEED		
FP	FUEL PUMP	PR	PROTECTIVE RELAY		

*Glows / Remote*

97422-1