

GR LEGEND - B=BAT C=CONT. E=ENG. F=FUEL G=GEN.  
 (GROUP) H=HOUSING R=RADIATOR Z=MISC.

60HZ SHD15000 (-3E/A), -4E/A, -17E/A /1PH\ /-< 3PH>-\  
 50HZ SHD12000 -517E/A < | -3E | -4E | -17E | >  
 GR | DESCRIPTION PART # < | QTY. | QTY. | QTY. | >

GR	DESCRIPTION	PART #	<   QTY.	QTY.	QTY.	>
1 B*	BAT. CABLE ASY 1GA (POS)	53220-039	1	1	1	1
2 B*	BAT. CABLE ASY 1GA (NEG)	53220-040	1	1	1	2
3 B*	BATTERY - 12VGP21 650CCA	96166-000	1	1	1	3
4 B*	BATTERY MTG. BRKT.	96166-000	1	1	1	4
5 B*	HOLD DOWN BRACKET	96718-000	1	1	1	5
6 B*	HOLD DOWN ROD	96717-000	2	2	2	6
7						7
8 C*	CIR.BRK. 15A-1PL-12VDC	94387-402	1	1	1	8
9 C*	CIR.BRK.15A-1PL	91286-000	1	1	1	9
10 C*	CIR.BRK.20A-1PL	91286-001	2	2	2	10
11 C*	CIR.BRK.20A-2PL-240V	57030-001	1	1	1	11
12 C*	CIR.BRK.30A 1PL	91286-009	1	1	1	12
13 C*	CIR.BRK.30A-3PL-240V	58483-001	--	1	1	13
14 C*	CIR.BRK.40A-3PL-240V	58483-00X	--	--	--	14
15 C*	CIR.BRK.50A-2PL-240V	57030-000	2	1	1	15
16 C*	CONTROL PANEL ASSY. -3E	97415-400	1	--	--	16
17 C*	CONTROL PANEL ASSY. -4E	97415-40X	--	1	--	17
18 C*	CONTROL PANEL ASSY.-17E	97415-401	--	--	1	18
19 C*	D.C. VOLTMETER	94395-000	1	1	1	19
20 C*	ENGINE CONTROL (ECM)	95689-000	1	1	1	20
21 C*	FUEL GAUGE	95648-000	1	1	1	21
22 C*	GAUGE, COOLANT TEMP.	94397-000	1	1	1	22
23 C*	GAUGE, OIL PRESSURE	94396-000	1	1	1	23
24 C*	GLOW PLUG INDICATOR	96578-002	1	1	1	24
25 C*	GROUND STRAP ASSY.	95231-001	1	1	1	25
26 C*	LAMP 14V BULB (PANEL)	94988-000	1	1	1	26
27 C*	LAMP 14V (INDICATOR)	94983-000	8	8	8	27
28 C*	LAMP HOLDER (PANEL)	94987-000	1	1	1	28
29 C*	LAMP SOCKET (INDICATOR)	94982-000	4	4	4	29
30 C	LENS-HIGH COOL TEMP (R)	94984-007	1	1	1	30
31 C	LENS-LOW OIL PRESS (R)	94984-002	1	1	1	31
32 C	LENS-OVERSPEED (R)	94984-001	1	1	1	32
33 C	LENS-SYSTEM NORMAL (G)	94986-001	1	1	1	33
34 C	PERIPHERAL SEAL	96927-004	1	1	1	34
35 C*	RECEPT NEMA 5-15R	24749-000	1	1	1	35
36 C*	RECEPT NEMA 5-20R	50766-000	1	1	1	36
37 C*	RECEPT NEMA 6-50R	57325-000	1	--	--	37
38 C*	RECEPT NEMA L5-20R	56279-000	1	1	1	38
39 C*	RECEPT NEMA L5-30R	56359-000	1	1	1	39
40 C*	RECEPT NEMA L6-20R	56281-000	1	1	1	40
41 C*	RECEPT NEMA L6-30R	57473-000	--	1	1	41
42 C*	RECEPT SPL-125/250V 50A	91889-000	1	1	1	42
43 C	RECEPT. CONNECTOR	96925-003	1	1	1	43
44 C*	RELAY-12 VDC SPDT	59944-002	1	1	1	44
45 C*	RUNNING TIME METER	58166-006	1	1	1	45
46 C*	START SWITCH	72252-001	1	1	1	46

DecB

94387-702

GR LEGEND - B=BAT C=CONT. E=ENG. F=FUEL G=GEN.  
 (GROUP) H=HOUSING R=RADIATOR Z=MISC.

60HZ SHD15000 (-3E/A), -4E/A, -17E/A /1PH\ /-< 3PH>-\  
 50HZ SHD12000 -517E/A <|-3E|-4E|-17E|>  
 GR| DESCRIPTION PART # <|QTY.|QTY.|QTY.|>

47	C*	START/GLOW SOLENOID	80980-000	2	2	2	47
48	C*	SWITCH, LAMP TEST-SP MOM	94388-404	1	1	1	48
49	C*	SWITCH, PANEL LIGHT-SPST	94388-402	1	1	1	49
50							50
51	E*	AIR FILTER & ELEMENT	97275-001	1	1	1	51
52	E*	AIR RESTRICTION GAUGE	97279-000	1	1	1	52
53	E*	BANJO BOLT 12M1.25	97432-000	1	1	1	53
54	E*	BANJO UNION	97431-000	1	1	1	54
55	E*	BREATHER PIPE ASSY.	97440-000	1	1	1	55
56	E	DC WIRING HARNESS	97273-400	1	1	1	56
57	E*	DRIVE DISK	96377-000	2	2	2	57
58	E	EL-HOS.ADPT.1/8X1/4	56879-000	2	2	2	58
59	E	ENG WIRING HARNESS	97334-001	1	1	1	59
60	E*	ENG-KUBOTA VH-1100	96578-001	1	1	1	60
61	E*	EXHAUST PIPE WELD	97270-001	1	1	1	61
62	E*	FLYWHEEL HOUSING	96066-000	1	1	1	62
63	E	HALF COUPL. 1-1/4	97259-000	1	1	1	63
64	E	HOSE- 1.25ID RB	81103-000	1	1	1	64
65	E	HX.RED.BUSH.3/8X1/2	56372-000	1	1	1	65
66	E	MP FIT. 1/4-18NP	91747-000	1	1	1	66
67	E	MTG. BRACKET, AIR CLNR.	93484-007	2	2	2	67
68	E*	MUFFLER WELDMENT	97438-000	1	1	1	68
69	E*	OIL PRESSURE SWTICH	72254-002	1	1	1	69
70	E*	VOLTAGE REG. 12V	96577-005	1	1	1	70
71	E*	WATER TEMP. SW. MOD.	72255-004	1	1	1	71
72							72
73	F*	ELECTRIC FUEL PUMP	81332-001	1	1	1	73
74	F	FILLER NECK	97250-002	1	1	1	74
75	F*	FUEL FILTER	97303-000	1	1	1	75
76	F*	FUEL SOLENOID MOD.	97302-400	1	1	1	76
77	F*	FUEL TANK 21.5 GAL	96118-000	1	1	1	77
78	F	HOSE- 1/4ID RB (FT)	40078-000	6	6	6	78
79	F*	SENDER, FUEL LEVEL	98433-000	1	1	1	79
80							80
81	G*	ARM/HUB ASSY. (-3) 1PH	96375-000	1	--	--	81
82	G*	ARM/HUB ASSY. (-4) 3PH	63850-001	--	1	--	82
83	G*	ARM/HUB ASSY. (-17) 3PH	63850-003	--	--	1	83
84	G*	ARM/HUB ASSY. (-517) 3PH	63850-004	--	**	**	84
85	G*	BR HLDR & RACK ASSY -1PH	54242-001	1	--	--	85
86	G*	BR HLDR & RACK ASSY -1PH	54242-000	1	--	--	86
87	G*	BR HLDR & RACK ASSY -3PH	63940-000	--	1	1	87
88	G*	BR HLDR & RACK ASSY -3PH	63940-001	--	1	1	88
89	G*	BRUSH ASSY. - AC	24981-000	12	16	16	89
90	G*	BRUSH ASSY. -'Q'	53949-000	2	--	--	90
91	G*	BRUSH HLDR MTG PLATE	53975-000	6	6	6	91
92	G*	BRUSH HOLDER SPACER	52559-000	2	2	2	92

95864-1  
 F850 w/o  
 connack

GR LEGEND - B=BAT C=CONT. E=ENG. F=FUEL G=GEN.  
 (GROUP) H=HOUSING R=RADIATOR Z=MISC.

60HZ SHD15000 (-3E/A), -4E/A, -17E/A /1PH\ /-< 3PH>-\  
 50HZ SHD12000 -517E/A < -3E -4E -17E >  
 GR | DESCRIPTION PART # < QTY. QTY. QTY. >

GR	DESCRIPTION	PART #	< QTY.	QTY.	QTY.	>
93 G*	BRUSH HOLDER - AC	23500-402	12	16	16	93
94 G*	BRUSH HOLDER -'Q'	23500-400	2	--	--	94
95 G*	CAPACITOR ASSY.	41221-000	3	3	3	95
96 G*	FAN ASSY.	23404-000	1	1	1	96
97 G*	FIBER SPACER	23532-000	14	16	16	97
98 G*	FIELD COIL ASSY. -1PH(L)	52563-000	1	--	--	98
99 G*	FIELD COIL ASSY. -1PH(R)	52563-001	1	--	--	99
100 G*	FIELD COIL ASSY. -3PH(L)	63938-000	--	1	1	100
101 G*	FIELD COIL ASSY. -3PH(R)	63938-001	--	1	1	101
102 G*	FLD RING & BRKT ASY	97288-000	1	1	1	102
103 G*	FLD SHL & COIL ASSY -1PH	97287-000	1	--	--	103
104 G*	FLD SHL & COIL ASSY -3PH	63939-000	--	1	1	104
105 G*	NOTCHED BEARING	59062-000	1	1	1	105
106 G*	POLE SHOE ASSY 8"	43473-000	2	2	2	106
107 G*	POLE SHOE RETAINER -1PH	43474-000	2	--	--	107
108 G*	POLE SHOE RETAINER -3PH	63937-000	--	2	2	108
109 G*	RECTIFIER	91452-000	1	1	1	109
110 G*	SLIP RING - 2 RINGS	50742-000	2	2	2	110
111 G*	WELDED END CVR ASSY	55438-015	1	1	1	111
112						112
113 H*	ANGLE CLIP	97233-000	1	1	1	113
114 H*	BASE WELDMENT	96153-000	1	1	1	114
115 H*	CONTROL COVER WELD	96570-000	1	1	1	115
116 H*	CONTROL MTG PANEL	96790-000	1	1	1	116
117 H*	CONTROL PANEL HINGE	96576-000	1	1	1	117
118 H*	CONTROL PANEL WELD	96574-000	1	1	1	118
119 H*	ENGINE MOUNT WELD	96182-000	2	2	2	119
120 H*	ENG/GEN BASE WELD	96158-000	1	1	1	120
121 H*	GEN MOUNT WELD	96370-000	2	2	2	121
122 H*	GRILL WELDMENT	96766-000	1	1	1	122
123 H*	HOUSING WELD. - GEN END	96550-000	1	1	1	123
124 H	HOUSING WELD. -ENG END	96475-000	1	1	1	124
125 H*	LIFTING CHANNEL WELD	96642-000	1	1	1	125
126 H*	LIFTING ROD	96648-000	2	2	2	126
127 H*	LOWER SIDE COVER (L)	96517-000	1	1	1	127
128 H*	LOWER SIDE COVER (R)	96516-000	1	1	1	128
129 H*	PROP ROD WELD - STRAIGHT	97228-000	1	1	1	129
130 H*	PROP ROD WELD - BENT	97232-000	1	1	1	130
131 H*	REAR LOWER COVER ASY	96569-000	1	1	1	131
132 H*	ROOF ASSY.	97446-400	1	1	1	132
133 H*	SERVICE DOOR ASSY. ←	97445-400 -	1	1	1	133 - 97471-0
134 H*	SHOCKMOUNT	97260-000	4	4	4	134
135 H*	SIDE DOOR ASSY.	97444-400 -	1	1	1	135-97471-
136	<i>(Key EM502) 97264 LATCH Lock 97264-0</i>		2	2	2	136 97249-
137 R	BRACKET, COOLANT BTL.	94339-000	1	1	1	137
138 R	COLLANT RECOVERY BTL.	94338-000	1	1	1	138

*BASE DOOR w/ prop Rod*

GR LEGEND - B=BAT C=CONT. E=ENG. F=FUEL G=GEN.  
 (GROUP) H=HOUSING R=RADIATOR Z=MISC.

60HZ	SHD15000 (-3E/A), -4E/A, -17E/A	/1PH\ /-< 3PH>-\ <   -3E   -4E   -17E   >	
50HZ	SHD12000 -517E/A	<   QTY.   QTY.   QTY.   >	
GR	DESCRIPTION	PART #	
139 R	FAN GUARD WELD	96843-000	1   1   1   139
140 R	FAN SHROUD	96511-000	1   1   1   140
141 R*	FAN SPACER	95854-001	1   1   1   141
135 R*	LWR.HOSE PIPE ADPT.	97267-000	1   1   1   135
136 R*	RADIATOR	97250-001	1   1   1   136
137 R	RADIATOR MOUNT	96769-000	2   2   2   137
138 R	RAD.HOS.1.5IDX1.5ID	92979-018	1   1   1   138
139 R	UPR.RAD.HOSE 1.5ID	93372-000	1   1   1   139
140			140
141 Z	DECAL - ELECT. OP. INST.	97338-000	1   1   1   141
142 Z	DECAL - ENGINE SERVICE	97334-000	1   1   1   142
143 Z*	COMPLETE UNIT ASSEMBLY	96754-000	1   --   --   143
144 Z*	COMPLETE UNIT ASSEMBLY	97561-00X	--   1   --   144
145 Z*	COMPLETE UNIT ASSEMBLY	97561-001	--   --   1   145
146 **	ENGINE OPERATOR'S MANUAL	96578-003	1   1   1   146
147 **	REPAIR PARTS LIST	60701-071	1   1   1   147
148 **	UNIT OPERATOR'S MANUAL	60706-057	1   1   1   148

	KUBOTA P/N	ENERGX #
OIL FILTER	15241-32099	N/A
AIR FILTER	>>----->	97275-0XX
FUEL FILTER ASSY	>>----->	97303-000
5 MICRON ELEMENT	>>----->	97303-001
10 MICRON ELEMENT	>>----->	97303-011

	SHD15000-(3E/A)	SHD15000-4E/A	SHD15000-17E/A
COMPLETE UNIT -	96754-000	97561-00X	97561-001
DC SCHEMATIC -	97422-000	97422-000	97422-000
AC WIRING -	97415-000	97415-00X	97415-001
DC WIRING -	97262-000	97262-001	97262-001
CONTROL PANEL -	97262-000	97262-00X	97262-001
CONTROL BOX -	97443-000	97560-00X	97560-001
ENG GEN SET -	97263-000	97263-003	97263-001
BR.RACK WIRING -	96376-000	63849-007	63849-005
AC RESIDUAL VOLTS	7.0 VAC L-L	7.0 VAC L-L	7.0 VAC L-L
AC OUT- 12VDC	200 VAC L-L	200 VAC L-L	200 VAC L-L
FIELD RESISTANCE	21.0 OHMS	26.5 OHMS	26.5 OHMS
WINDING SPEC. (SS#)	1509	1511	1512
ARM. CONNECTION (AC#)	254	133	362

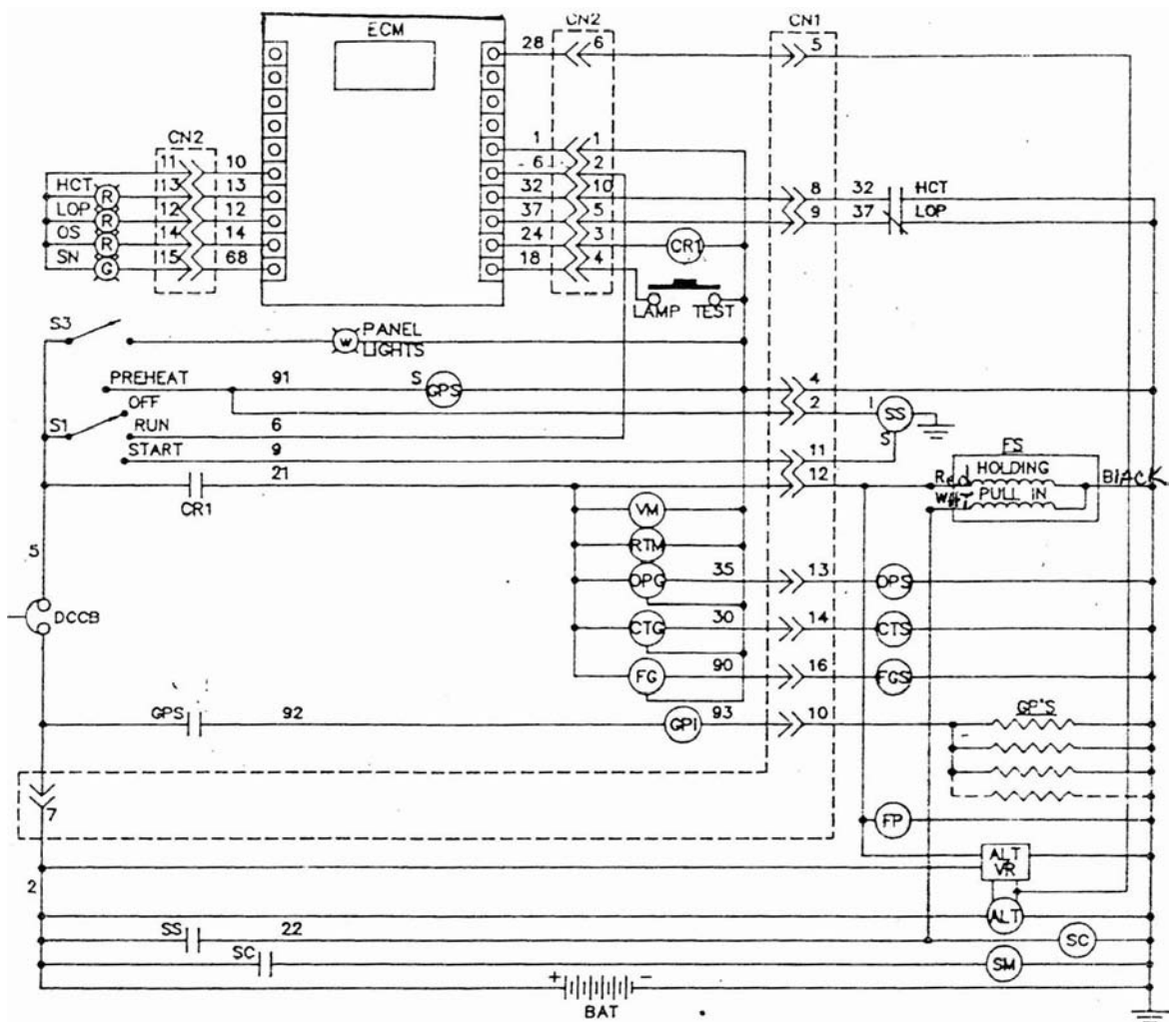

**LEGEND**

ALT	ALTERNATOR	FS	FUEL RACK SOLENOID	OS	OVERSPEED
ALT-VR	ALTERNATOR VR	GND	GROUND	RC	RECEPTACLE CONNECTOR
BAT	BATTERY	GP'S	GLOW PLUGS	RTM	RUNNING TIME METER
CB	CIRCUIT BREAKER	GPI	GLOW PLUG INDICATOR	S	SWITCH
CTG	COOLANT TEMP. GAUGE	GPS	GLOW PLUG SOLENOID	SC	START CONTACTOR
CTS	COOLANT TEMP. SENDER	GPS	LOW COOLANT TEMP.	SM	STARTING MOTOR
FG	FUEL GAUGE	LOP	LOW OIL PRESSURE	SN	SYSTEMS NORMAL
FGS	FUEL GAUGE SENDER	OPG	OIL PRESSURE	SS	START SOLENOID
FP	FUEL PUMP	OPS	OIL PRESSURE SENDER	VM	VOLTMETER

