

REVISIONS					
REV.	IRN	DESCRIPTION	DATE	BY	APP'D
A	C6068	ORIGINAL	8/29/2018	BWZ	DRD

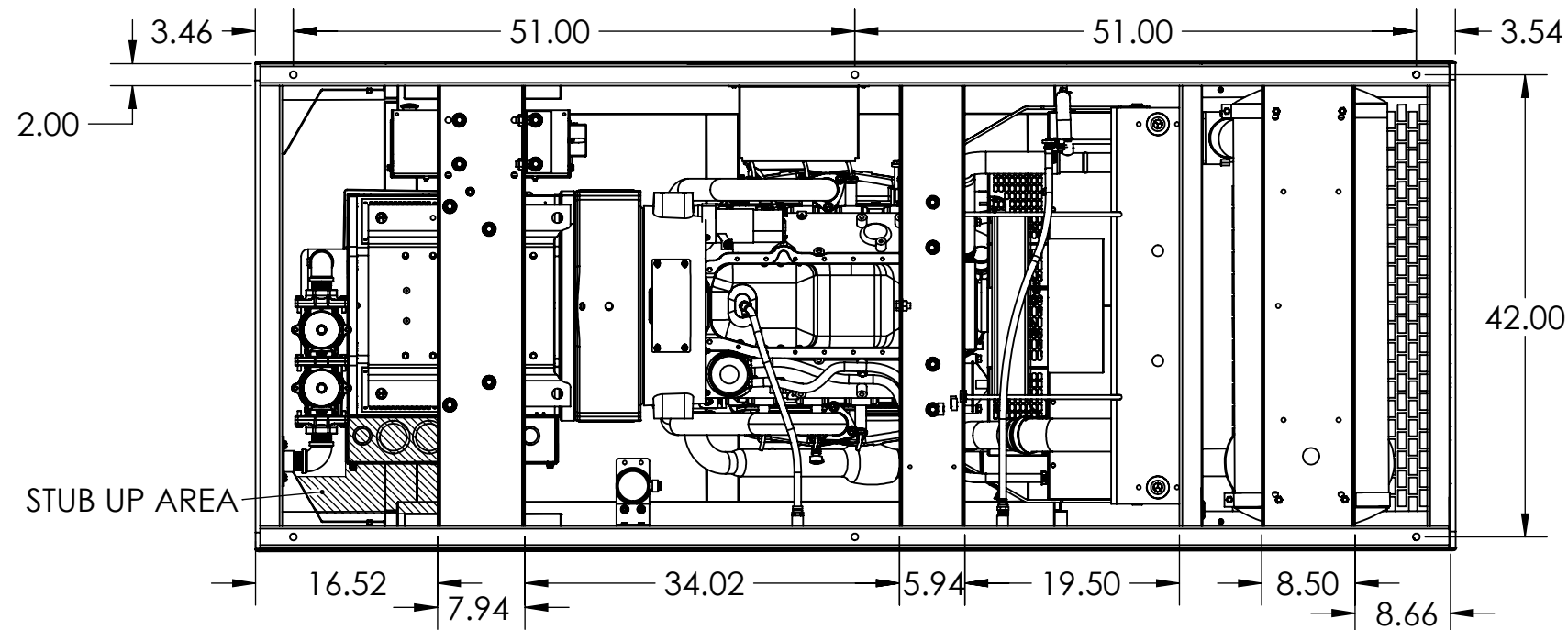

<p>THIS DRAWING CONTAINS PROPRIETARY INFORMATION BELONGING TO WINGCO. UNAUTHORIZED USE IS PROHIBITED.</p> <p>ALL DIMENSIONS INCH</p>	DRAWN BY	DATE	CHK'D BY	DATE	ENG APPR.	DATE	
	MML	7/10/2017			DRD	8/30/15	
	TOLERANCE:	+/- 0.0625 DECIMAL		+/- 1 DEG ANGULAR		TITLE:	PSS90 OUTLINE DRAWING
	MODEL:	ULPSS90-3D		PART:		O-524	1 of 2

REVISIONS					
REV.	IRN	DESCRIPTION	DATE	BY	APP'D
A	C6068	ORIGINAL	8/29/2018	BWZ	DRD

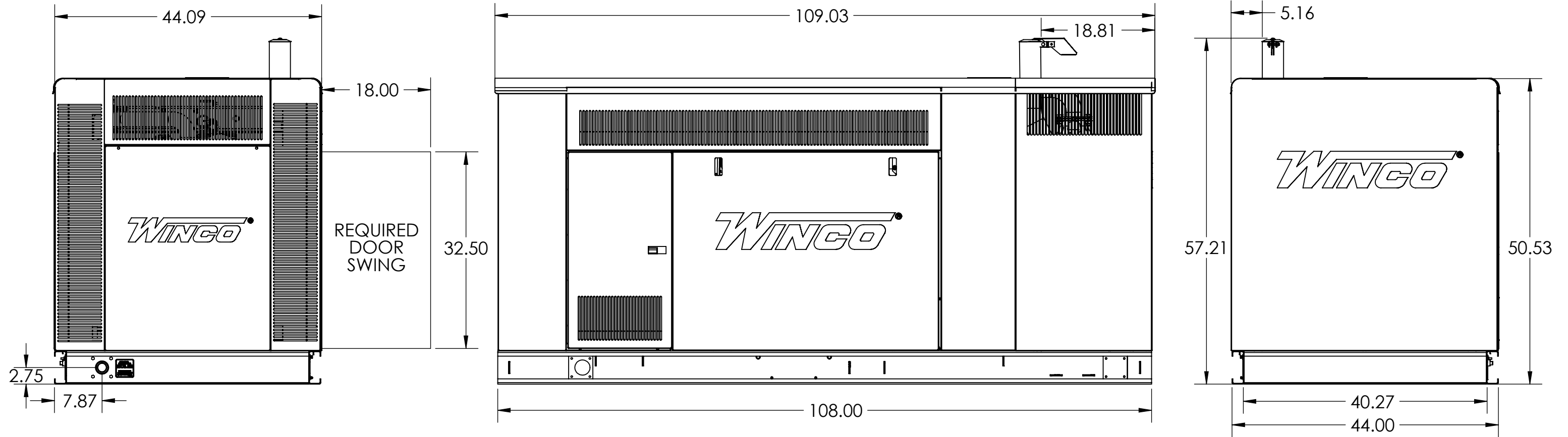
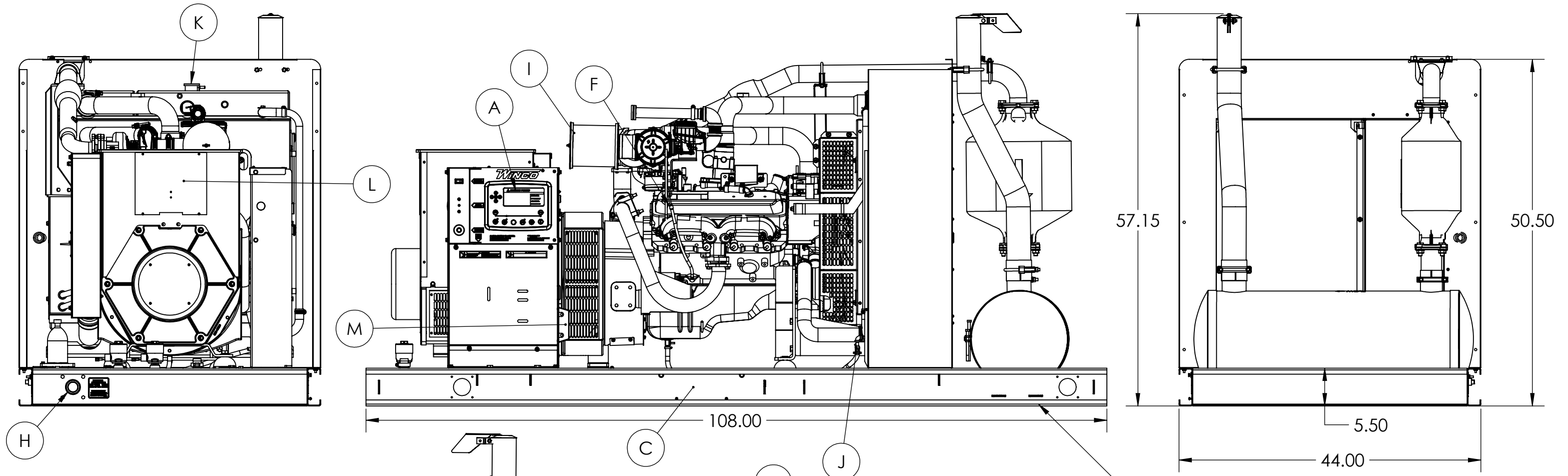

FRAME HAS THE SAME MOUNTING HOLE LOCATIONS AS THE HOUSED UNIT

KEY COMPONENTS	
A	ENGINE CONTROL
B	MAIN LINE CIRCUIT BREAKER
C	GROUP 24 BATTERY (NOT INCLUDED)
D	OIL FILL
E	OIL DRAIN
F	OIL DIPSTICK
G	OIL FILTER
H	FUEL INLET
I	AIR FILTER
J	COOLANT DRAIN
K	COOLANT FILL
L	AVR
M	BATTERY CHARGER

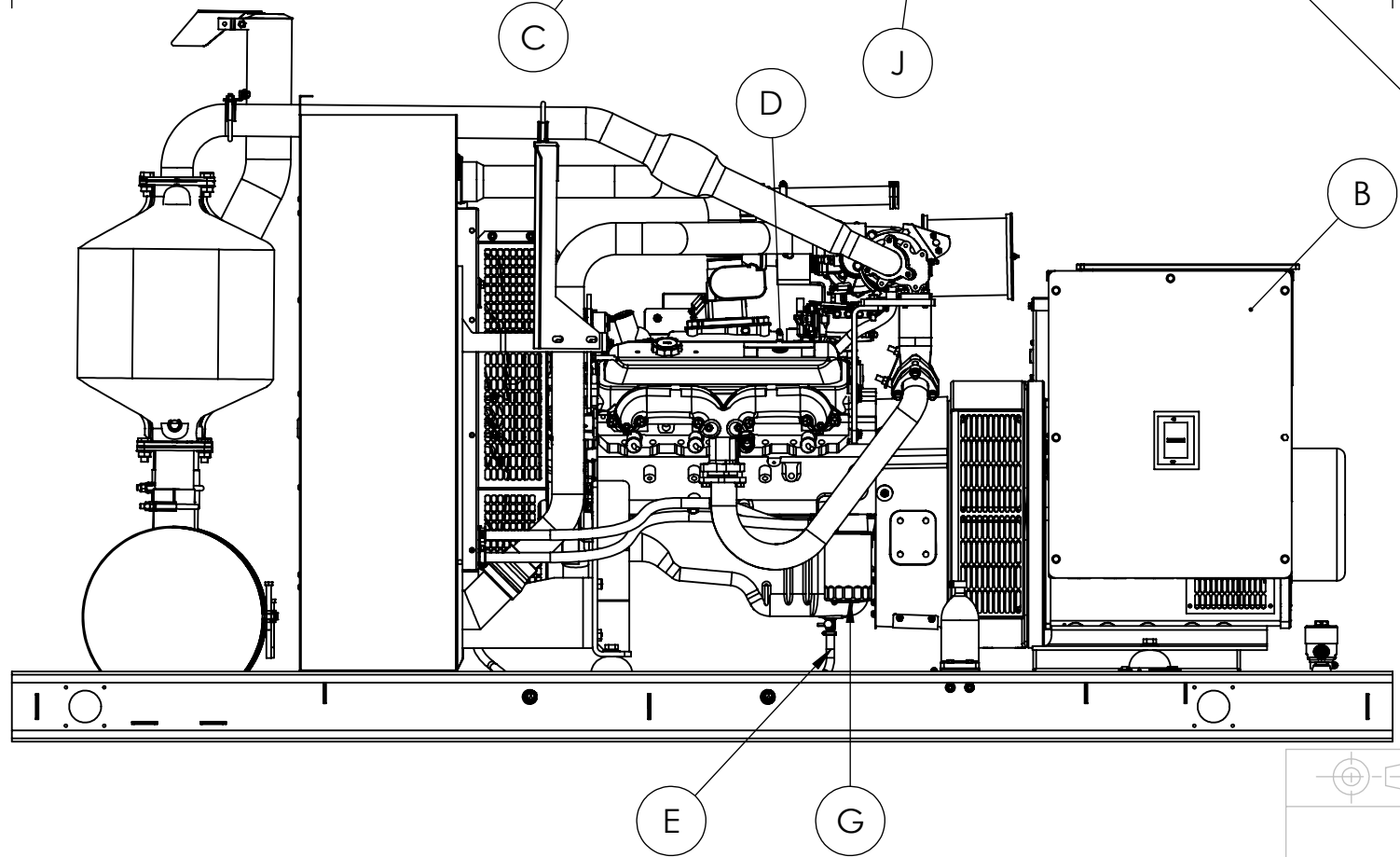

<p>THIS DRAWING CONTAINS PROPRIETARY INFORMATION BELONGING TO WINCO. UNAUTHORIZED USE IS PROHIBITED</p>	DRAWN BY MML	DATE 7/10/2017	CHK'D BY	DATE	ENG APPR. DRD	DATE 8/30/18
	TOLERANCE:	+/- 0.25" (UNLESS SPECIFIED)		TITLE:		
	WEIGHT:	1055.16 LBS		PSS90 OUTLINE DRAWING		
	MATERIAL:	SEE TABLE		PART: O-524		
	MODEL:	ULPSS90-3D		SHT 2		