

WINPOWER

*A Division of **DTE** Dyna Technology Inc*

DIESEL GENERATOR SYSTEMS

**DR45 - DR350
With DSE7X10
DEEP SEA
Engine Control**

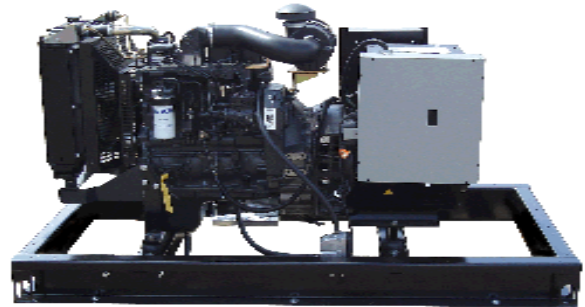

**WINPOWER[®]
POWR-PAK[®]**



**WINPOWER[®]
WEATHR-PAK[®]**



**WINPOWER[®]
SOUND-PAK[®]**

**INSTALLATION AND
OPERATIONS MANUAL**

DR45I4 Shown for Comparison

SAVE THESE INSTRUCTIONS

This manual contains important instructions that should be followed during installation and maintenance of the generator and batteries.

Read and understand all instructions in the manual before starting and operating the generator set.

USING THIS MANUAL

Congratulations on your choice of a Winpower generator set. You have selected a high-quality, precision-engineered generator set designed and tested to give you years of satisfactory standby service.

To get the best performance from your new engine generator set, it is important that you carefully read and follow the operating instructions in this manual.

Should you experience a problem please follow the "Things To Check" near the end of this manual. The warranty listed in this manual describes what you can expect from WINPOWER should you need service assistance in the future.

COPY YOUR MODEL AND SERIAL NUMBER HERE

No other WINPOWER generator has the same serial number as yours. It is important that you record the number and other vital information here. If you should ever need to contact us on this unit it will help us to respond to your needs faster.

MODEL _____

SERIAL NUMBER _____

'M" Spec. _____

PURCHASE DATE _____

DEALER _____

TABLE OF CONTENTS

INTRODUCTION	i
GUIDE TO PRODUCT SAFETY	1
BASIC INFORMATION	2
Description	2
DSE7X10 Engine Control Layout	3
DSE7X10 Display Operations	4
RECEIVING THE GENERATOR	5
Unpacking the unit	2
Lifting the unit	5
ENGINE GENERATOR INSTALLATION	
Installation	6
Engine Generator Set Mounting	7
Fuel Installation	7
Lubrication	7
Coolant	7
Battery Installation	7
Battery Charger/Block Heater Wiring	8
Mounting The Transfer Switch	8
AC ELECTRICAL CONNECTIONS	9
DC ELECTRICAL CONNECTIONS	10
INITIAL START-UP	12
EXERCISER CLOCK	13
TROUBLESHOOTING INFORMATION	13
APPENDIX DIRECTORY	14
Appendixes	15-24
12 MONTH WARRANTY	25

PROPER USE AND INSTALLATION

You must be sure your new engine generator set is:

- * Properly serviced before starting
- * Operated in a well ventilated area
- * Properly exhausted and gases safely dispersed
- * Wired by a qualified electrician
- * Operated only for its designed purposes
- * Used only by operators who understand its operation
- * Properly maintained

IMPORTANT SAFETY INSTRUCTIONS

SAVE THESE INSTRUCTION

This manual contains important instructions that should be followed during installation and maintenance of the generator and batteries.

Read and understand all instructions in the manual before starting and operating the generator set.

This engine generator set has been designed and manufactured to allow safe, reliable performance. Poor maintenance, improper or careless use can result in potential deadly hazards; from electrical shock, exhaust gas asphyxiation, or fire. Please read all safety instructions carefully before installation or use. Keep these instructions handy for future reference. Take special note and follow all warnings on the unit labels and in the manuals.

ANSI SAFETY DEFINITIONS

DANGER:

DANGER indicates an imminently hazardous situation which, if not avoided, will result in death or serious injury. This signal word is to be limited to the most extreme situations.

WARNING:

WARNING indicates a potentially hazardous situation which, if not avoided, could result in death or serious injury.

CAUTION:

CAUTION indicates a potentially hazardous situation which, if not avoided, may result in minor or moderate injury. It may also be used to alert against unsafe practices.

NOTE:

CAUTION is also used on the unit labels and in this manual to indicate a situation that could result in serious damage or destruction of the equipment and possible personal injury.

1. **ELECTRIC SHOCK** - The output voltage present in this equipment can cause a fatal electric shock. This equipment must be operated by a responsible person.
 - a. Do not allow anyone to operate the generator without proper instruction.
 - b. Guard against electric shock.
 - c. Avoid contact with live terminals or receptacles.
 - d. Use extreme care if operating this unit in rain or snow.
 - e. Use only three-prong grounded receptacles and extension cords.
 - f. Be sure the unit is properly grounded to an external ground rod driven into the earth.

2. **FIRE HAZARD** - Deisel fuel presents a hazard of possible explosion and/or fire.
 - a. Do not smoke or use open flame near the generator set.
 - b. Keep a fire extinguisher nearby and know its proper use. Fire extinguishers rated ABC by NFPA are appropriate.
3. **DEADLY EXHAUST GAS** - Exhaust fumes from any diesel engine contain carbon monoxide, an invisible, odorless and deadly gas that must be mixed with fresh air.
 - a. Operate only in well ventilated areas.
 - b. Never operate indoors.
 - c. Never operate the unit in such a way as to allow exhaust gases to seep back into closed rooms (i.e. through windows, walls or floors).
4. **NOISE HAZARD** - Excessive noise is not only tiring, but continual exposure can lead to loss of hearing.
 - a. Use hearing protection equipment when working around this equipment for long periods of time.
 - b. Keep your neighbors in mind when permanently installing this equipment.
5. **CLEANLINESS** - Keep the generator and surrounding area clean.
 - a. Remove all grease, ice, snow or materials that create slippery conditions around the unit.
 - b. Remove any rags or other material that could create potential fire hazards.
 - c. Carefully wipe up any fuel or oil spills before starting the unit.
 - d. Never allow leaves or other flammable material to build up around the engine exhaust area.
6. **SERVICING EQUIPMENT** - All service, including the installation or replacement of service parts, **should be performed only by a qualified technician.**
 - a. Use only factory approved repair parts.
 - b. Do not work on this equipment when fatigued.
 - c. Never remove the protective guards, cover, or receptacle panels while the engine is running.
 - d. Use extreme caution when working on electrical components. High output voltages from this equipment can cause serious injury or death.
 - e. Always avoid hot mufflers, exhaust manifolds, and engine parts. They all can cause severe burns instantly.
 - f. Installing a generator set is not a "do-it-yourself" project. Consult a qualified, licensed electrician or contractor. The installation must comply with all national, state, and local codes.
 - g. Always make sure unit is disabled before placing your hands anywhere near the fan, belts, alternator or water hoses.

TESTING POLICY:

Before any generator is shipped from the factory, it is fully checked for performance. The generator is loaded to its full capacity, and the voltage, current, and frequency are carefully checked.

Rated output of generators is based on engineering tests of typical units, and is subject to, and limited by, the temperature, altitude, fuel, and other conditions specified by the manufacturer of the applicable engines.

INTRODUCTION AND DESCRIPTION

PRODUCT DESCRIPTION:

This engine-generator set is designed for unattended remote start operation. It can be operated as part of a fully automatic standby power system or independently as a local start unit in a prime power system. The engine-generator set is fully tested at the factory prior to shipment to insure proper operation of each individual component as well as the total system's performance and reliability.

The engine generator set consists of a multi-cylinder, liquid cooled engine nominally operating at 1800 rpm. The generator frequency regulation is maintained by the engine governor to within +/- 1.5 hertz (cps), from no load to rated load for standard mechanical governors and to within +/- .5 hertz or better for units equipped with an electronic governor. The generator is a single bearing, direct drive, rotating field design. The generator is connected to the engine flywheel via flexible drive disks. The Generator Set is skid mounted with isolation mounts between the engine and base on all units.

Unit Orientation Note: All references used in this manual for unit familiarization, access and component locations on the Generator Set are oriented from a TOP (plan) VIEW with engine at the FRONT and generator to the REAR.

WINPOWER uses a common junction box for all customer control and power connections (both AC output and DC control). The common electrical junction box is always on the left side at the generator end of the machine.

A customer supplied 12 (or 24) Volt battery is required to complete the installation. See appendix 1, to identify the voltage, size and CCA (Cold Cranking Amp) requirements for your specific unit.

The engine is controlled and Generator Set operation is monitored for safe operation by a programmable microprocessor based Electronic Engine Control Module (ECM) with an LCD digital display. The Generator Set ECM control is mounted on a vertical pedestal on the right side of the generator. The ECM is programmed with a cycle cranking sequence - 3 cycles of 15 seconds on / 15 seconds off, and a 5 minute cool down delay. The cool down delay can be changed in the field from 0 to 30 minutes by your dealer. Other features, timing cycles, set points and signal output capabilities are possible. Consult factory for procedure and passwords.

**** NOTICE ****

These units will automatically transfer if a power outage occurs while running in an exercise mode.

MODEL NUMBER STRUCTURE:

The WINPOWER alpha-numerical numbering system consists of a base model designation, followed by an options section, separated by a dash mark. The base component of the model numbering system identifies an engine type, engine starting method, fuel type, kilowatt rating, engine manufacturer, and number of generator poles. Following the separation dash mark is the voltage connection and optional installed equipment. Options include features like weather enclosures (housing), base mounted fuel tank sizes, and trailer options.

Please note that some features or packages, such as NFPA level I & II, do not have an indication place in this numbering system. They are issued and built with an M-Spec (i.e. M-10372) number which can be found on the WINPOWER data tag. When the M-Spec is present, supplemental inserts will accompany this standard manual providing information about the special equipment and features installed. The standard model numbering key that can be used along with the data tag information and/or M-spec supplements to determine the generator sets ratings and specifications

WINPOWER	
MODEL NUMBERING SYSTEM	
BUILD YOUR GENSET REQUIREMENT FROM THE BOTTOM OF THE PAGE TO THE TOP	
T	TRAILER OPTION IF PRESENT UNIT IS MOUNTED ON A TRAILER WITH FUEL TANK FUEL. TANK SIZES SHOWN BY PREVIOUS LETTER (SMALL AND MEDIUM FUEL TANKS ONLY)
M	FUEL TANK SIZE S = SMALL L = LARGE SEE CURRENT PRICE SHEET M = MEDIUM * = NONE TO DETERMINE CAPACITY
H	HOUSING TYPE H = WEATHER HOUSING (WEATHER-PAK) * = NO HOUSING A = SOUND ATTENUATED/WEATHER PROTECTIVE (SOUND-PAK)
A	VOLTAGE X = SWITCHABLE A = SINGLE PHASE 120/240 J = THREE PHASE 120/240 D = THREE PHASE 120/208 L = THREE PHASE 277/480
-	BASE UNIT - OPTIONS SEPARATOR
4	NUMBER OF POLES ON THE GENERATOR 4 POLES STANDARD
I	ENGINE MANUFACTURE V = VOLVO I = ISUZU (10 & 20 kW) G = GM D = DEUTZ I = IVECO (ALL OTHERS) N = NG ENGINES
20	KILOWATTS GENERATOR OUTPUT IN KILOWATTS WITH STANDBY
N	GASEOUS FUEL TYPE N = NATURAL GAS L = L/P LIQUID WITHDRAWAL P = LIQUID PROPANE VAPOR NOT USED WITH DIESEL FUEL
R	STARTING METHOD R - REMOTE STARTING
G	FUEL TYPE D = DIESEL G = GASEOUS

SPECIFICATIONS

GENERATOR SET:

Every WINPOWER Generator Set has its own unique identity data plate. This data plate identifies the complete unit model number, the system serial number and has links to the individual components that form the generator set in our factory records. Several of the major components also have their own individual identity plates providing additional information to document build data for warranty and replacement parts.

WINPOWER GENERATOR SET			
VOLTS	120/208	MODEL NO.	DR175I4-D
HERTZ	60	R.P.M.	1800
DUTY	CONT.	STANDBY	PHASE 3
AMPS	546	607	P.F. .8
K.W.	157	175	INS. H
K.V.A.	196	218	AMB. TEMP. 40°C
SERIAL NO. 2007325001		TYPE NO. M-10848	
FITTED WITH RAINPROOF ENCLOSURE MAX LOAD UNBALANCED - 50%			
WINPOWER LE CENTER MN 56057 U.S.A.			

Typical Winpower Nameplate

Be sure to have the main WINPOWER unit data plate information recorded inside the front cover of this manual for future reference and for identification whenever requesting field or factory technical assistance. Sample data plate is shown for reference. Primary fields needed for assistance are complete model number, serial number and especially the M-Spec number. The M-Spec number (if provided) is recorded in the 'TYPE NO.' block on the Lower Right of the plate. See the appendix in the back of this manual for individual units specifications and wiring diagram references.

ENGINE:

Each engine has a nameplate on it that gives the specific engine model number, build specification and the serial number for the engine. See the technical data pages in the back of this manual for individual engine specifications, fuel consumptions and wiring diagram references.

This manual covers specific operation of the combined engine generator set. Refer to engine operating and maintenance instructions for specific instruction on the care and maintenance of the engine. Oil and fuel requirements along with maintenance schedules and engine warranty information are provided by the individual engine manufactures.

** CAUTION **

EQUIPMENT DAMAGE - Be sure to check the engine oil level frequently as specified in the engine manual.

The engine manufacturer has established an excellent worldwide engine service organization; engine service is available from a nearby authorized dealer or distributor; check the Yellow Pages of the telephone directory under "engines," or ask the dealer from whom you purchased the power plant.

The rated power of each engine-generator is limited by the temperature, altitude and all other ambient conditions specified by the engine manufacturer. Engine power will decrease 3-1/2% for each 1000 ft. above sea level, and will decrease an additional 1% for each 10 degrees Fahrenheit above 60 degrees Fahrenheit. Units should not be operated in ambient temperature greater than 125 degrees Fahrenheit.

GENERATOR:

WINPOWER Generators Sets use totally brushless, AVR (Auto-Voltage Regulator) controlled broad-range generator ends. The generator converts rotational mechanical energy into electrical energy. Standard WINPOWER units are equipped with generators manufactured by Stamford/Newage. Each generator 'end' has its own data tag. The unique serial number is stamped on the data plate and into the upper section of the mounting adapter of the generator frame. The data label is affixed to the main frame of the generator on the lower left side, similar to the sample shown.

SERIAL NUMBER	A068529666	<h2 style="text-align: center;">NEWAGE</h2> <p>NEWAGE INTERNATIONAL LTD PO BOX 17, BARNACK RD STAMFORD, LINCOLNSHIRE PE9 298, ENGLAND</p> <p>43875 04/13/06</p> <p>WARNING REFER TO THE INSTRUCTIONS BOOK BEFORE FLASH OR MEGGA TESTING</p> <p>BS 5000: PART 3 IEC 34- NEMA MG 1-20 ISO 8528-3</p> <h2 style="text-align: center;">STAMFORD</h2> <p style="text-align: center;">AC GENERATORS</p>
MACHINE ID	4/10	
FRAME / CORE	UC 224FL 64D	
KVA BASE RATE (BR)	86.7	
KW BASE RATE (BR)	71	
HZ	60	
RPM	1800	
VOLTS	208	
PHASE	3	
AMPS BASE RATE (BR)	247	
PF	0.8	
RATING	Standby	
EX. VOLTS	36	
EX. AMPS	1.8	
AMBIENT TEMP C	40	
ENCLOSURE	IP22	
INSULATION CLASS	H/L1446	
STATOR WDG.	311	
STATOR CONNL.	PARALLEL STAR	
AVR	5X460	
KVA PEAK RATE (BR)		
MAX HRS P A PR		
TEMP RISE	1.50	

ENGINE CONTROL PANEL LAYOUT

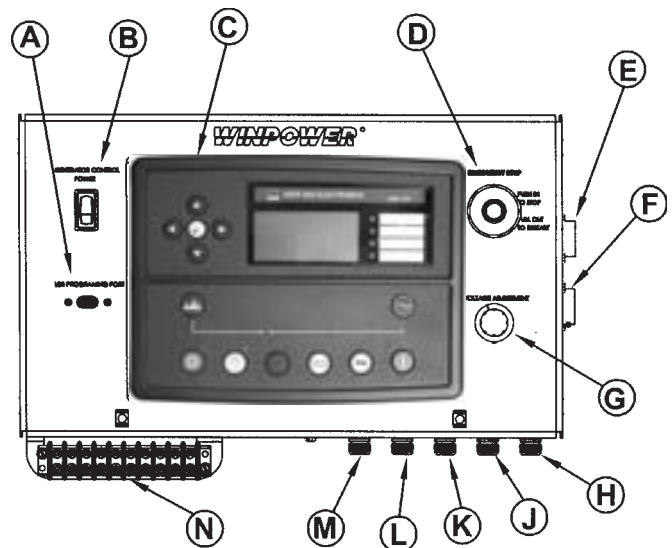

A. USB PROGRAMMING PORT - USB port for computer interface. Used for programming the DSE7X10 controller.

B. GENERATOR CONTROL POWER - Battery disconnect switch for engine control. Used during long term storage to prevent battery discharge

C. DSE7X10 CONTROLLER - See controller explanation below.

D. Emergency Stop Switch - When depressed this switch will disconnect all the 12 volt power to the DSE7X10 shutting the engine down. The display on the controller will annunciate "Emergency Stop".

E. AC INTERFACE CONNECTOR - This connector is used to interface with the AC generator end. It provides the controller with the voltage, amperage and frequency reading for the display.

F. DC INTERFACE CONNECTOR - This connector provides all the interface connections for the engine. Including the DC power supply to operate the DSE7X10 controller. Engine CAN connections are also made through this connector providing the controller with the engine operational reading.

G. VOLTAGE ADJUSTMENT - This rheostat is used to fine tune the AC output voltage after changing the voltage selector switch.

H. 10 AMP FUSE This fuse supplies the DSE7X10 controller 12 Volt DC for all controller switching functions. (Replacement AGC-10A-250V)

J. 3 AMP FUSE -This fuse supplies the 12 volt DC to power the DSE7X10 controller circuitry on the board. (Replacement AGC-3A-250V)

K, L, M. 2 AMP FUSE- These fuses are in the AC input line from the generator. These are the feeds that provide the AC voltage reading on the display. If one of these is blown the controller will not show the proper voltage on one leg and may shutdown for low voltage. (Replacement AGC-2A-250V)

N. CUSTOMER DC INTERCONNECTIONS - See page 10 for additional details.

DSE 7X10 Series CONTROLLER

A. MENU NAVIGATION BUTTONS – Left and Right buttons select different grouping (i.e. Engine reading, Generator reading, etc.) Up and down buttons scroll through the different reading for each group.

B. STOP/RESET – This button places the module into its STOP/RESET mode. This will clear an alarm conditions for which the triggering criteria have been removed. If the engine is running and this button is pushed the module will shut off the fuel solenoid and the engine will come to a stop. If a remote start signal is received while this switch is activated, the unit will not start.

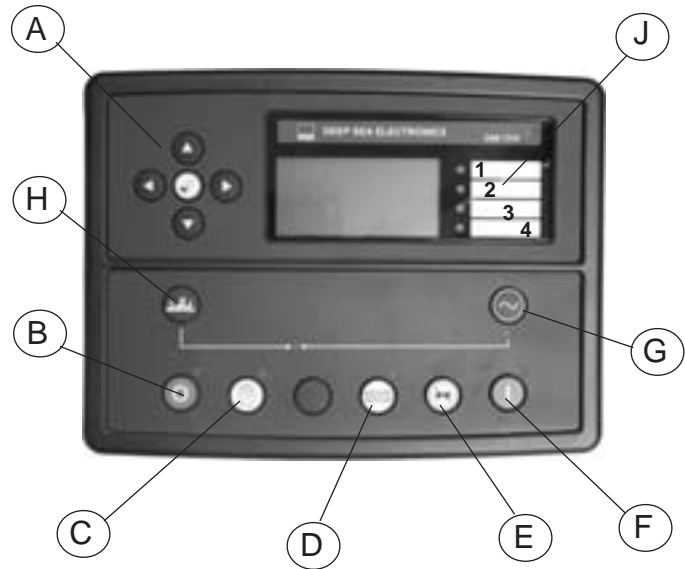

C. MANUAL - This mode allows manual control of the generator functions. Once in the MANUAL mode the module will allow you to start the unit using the START button. The unit will continue to run until either the STOP/RESET or AUTO button is pressed. If the unit receives a remote start signal during manual operation, the generator will remain running even after the remote start signal has been lost. You must use the STOP/RESET or AUTO button to stop the unit once you have started it in manual mode.

**** CAUTION ****

IF THE POWER FAILS WHILE RUNNING IN THE MANUAL MODE THE TRANSFER SWITCH WILL TRANSFER THE LOAD TO THE GENERATOR. TO PREVENT THIS THE MAINLINE CIRCUIT BREAKER ON THE GENERATOR MUST BE OPENED.

D. AUTO – This button places the module into its AUTOMATIC mode. This module will monitor the remote start input for a relay closure. When the remote start signal is received it will time out the start delay (5 Seconds) and then start the engine generator set. When the remote start signal is lost (relay opened up) the module will shut the engine generator set down after the cool down timer has time out. The module will return to the auto start mode and await the next start signal.

E. LAMP TEST/HORN RESET - This button silences the audible alarm if it is sounding and illuminates all of the LEDs as a lamp test feature. When configured and fitted to a compatible engine ECU, pressing this button in STOP/RESET mode after pressing the START button (to power the ECU) will cancel any "passive" alarms on the engine ECU.

F. START – This button is active only in the MANUAL or STOP/RESET mode. Pressing this button in the MANUAL mode will start the engine locally for testing. The engine will continue to run until either the STOP/RESET or the AUTO button is pressed. Pressing this button with the control in the STOP/RESET mode will turn on the CAN engine ECU (when correctly configured and fitted to a compatible engine ECU)

G. CLOSE GEN-SET – NOT USED IN THIS APPLICATION

H. OPEN GEN-SET – NOT USED IN THIS APPLICATION

J. USER CONFIGURABLE INDICATORS –

1. Remote Start.
2. Not Used
3. Not Used.
4. Emergency Stop

NOTE: STOP/RESET, MANUAL mode and AUTO mode buttons all have indicator lamps next to them to tell you what mode you are in. Pressing buttons out of sequence will cause the engine not to function properly.. See button operation sequencing above.

.RECEIVING THE GENERATOR

The generator set will generally be shipped by a commercial 'common freight carrier'. Large and bulky units are often shipped on a dedicated or specially contracted 'Flat-Bed' truck. The means of shipment is determined in consultation between the WINPOWER Sales and Shipping staff and the customer. Routing is determined by the bulk, size, and a means available to unload the generator at the receiving end. WINPOWER recommends units that are shipped by common carrier be delivered to a commercial dock to allow the Generator Set to be unloaded in a safe, efficient manner and to minimize handling damage to the unit.

Locate the packing slip on the side of the crate or request it from the truck driver. When receiving the unit take special care in examining the unit for damage during shipment. Avoid signing for the equipment until a full visual assessment and inventory have been made. Verify that you have received the right equipment and the proper amount by matching up the equipment to the packing list. Larger units may ship with the fuel tank and muffler removed. Verify that those components are undamaged and removed from the truck prior to their release.

The keys for doors of the enclosed generators sets are typically attached to lifting eye on the base of the machine. These keys are matched to all the doors on the generator set housing.

UNPACKING INSTRUCTIONS:

When unpacking the generator set, be sure to inspect it carefully for freight loss or damage. If loss or damage is noted at the time of delivery, require that the person making the delivery make note of the loss or damage on the freight bill, or affix his signature under the consignee's memo of the loss or damage. Contact the carrier for claim procedures.

When loss or damage is noted after delivery, segregate the damaged material, and contact the carrier for claim procedures.

"Concealed Damage" is understood to mean damage to the contents of a package which is not in evidence at the time of delivery by the carrier, but which is discovered later. The carrier or carriers are responsible for merchandise lost or damaged in transit. The title to goods rests with the consignee when generators are shipped fob factory, and only the consignee can legally file a claim.

***** CAUTION *****

EQUIPMENT DAMAGE - These units are shipped with oil, and a 50/50 mix of coolant. Be sure to check all fluid levels before operating. See engine manufacturer's instruction manual for recommended oil requirements before initial starting.

UNPACKING:

(Not recommended until the unit is on-site)

1. Carefully remove the crate.
2. After inspecting the engine-generator for external physical damage, locate and check the following items packed with the unit.
 - a. Owner's operators manual.
 - b. Engine manufacturer's instruction manual.
 - c. Battery hold-down brackets & hardware.
 - d. Unit components or accessory items shipped loose for on-site installation.
 - e. Optional accessories (i.e. remote annunciator)
3. Remove main frame hold down bolts.
4. Unit can now be lifted from shipping rails.

LIFTING THE GENERATOR SET

NOTICE - Personal Injury

To prevent injury to persons or equipment, observe the following guidelines when lifting the generator:

Due to the different designs, configurations, options, weights, site conditions, and available material handling equipment, specific lifting instructions are not provided for each individual generator set model. General guidelines provided are applicable to the entire standby generator line. It is the responsibility of the installing party to follow the lifting equipment's operators manual to prevent injury to personnel and damage to the generator. Smaller Generator Sets may not require use of overhead lifting equipment and may be placed on the pad with basic material handling equipment, i.e. a forklift.

CAUTION: - Do not attempt to lift the generator set by the means of the lifting eyes on the engine or generator end.

These lifting points are only for use during the manufacturing process and are designed for lifting of the individual Generator Set component.

WINPOWER has designed all of its Generators Sets to be lifted at the corners with an appropriate lifting rig. The lifting points are located on the side rails of the generator base or on the optional base mounted fuel tank of a Diesel Generator Set.

The generator set can be lifted with properly rated chains or cables along with the use of spreader bars. The spreader bars should be long enough so that the lift cables or chains do not come into contact with the generator set. Use of commercially available lifting fixtures may also be used. Always be sure that the equipment is properly rated for the weight of the generator. Failure to do so can cause damage to the generator, injury to personnel or even death.

The generator set and fuel tank may or may not be shipped as a complete unit. If the fuel tank is shipped separate from the generator, place the tank on the cement pad first, and then place the generator on top of the fuel tank.

 ***** **WARNING** *****

NEVER - attempt to lift the fuel tank while filled with fuel. Sloshing of the fuel can cause a shift in the balance of the fuel tank, making for a DANGEROUS, unbalanced lifting load. If the generator was shipped on the fuel tank, use the lifting points located on the fuel tank to move the entire Generator Set into place. DO NOT place fuel in the tank prior to lifting.

Depending on generator set size and configuration, the exhaust system may 'ship loose' with the generator set for installation on site. The muffler and its attaching brackets must be mounted on top of the generator housing prior to operating the engine generator set.

INSTALLATION

 ***** **WARNING** *****

PERSONAL INJURY - Before proceeding with the installation, be sure the DSE7X10 is in the "stop" position. Before proceeding with the installation, be sure the Generator MLCB (Main Line Circuit Breaker) is in the 'OFF' position and the unit starting battery is disconnected.

GENERAL INFORMATION

These engine/generator sets are generally supplied as weather enclosed packages for quick installation on an outdoor concrete pad. They are also available as open skid mounted units for indoor installation in a building or protective enclosure supplied by the installer. The factory weather enclosures are available as standard or acoustical housing intended for outdoor installation only. **Factory weather enclosed units are not intended to be used indoors and no support is available to assist in re-engineering finished packaged units.**

All versions must be bolted to a solid base for proper operation. A properly designed concrete pad is necessary for stationary operation. A substantial DOT certified trailer is required for mobile applications. Consult a qualified, licensed electrician or contractor to install and wire this Generator Set. **The installation must comply with all national, state, and local codes.**

Before beginning the installation process, recheck the voltage, phase and amperage rating of the Generator Set and ATS (Automatic Transfer Switch). Be certain they can handle the intended load and are compatible with the entrance voltage, phase and current

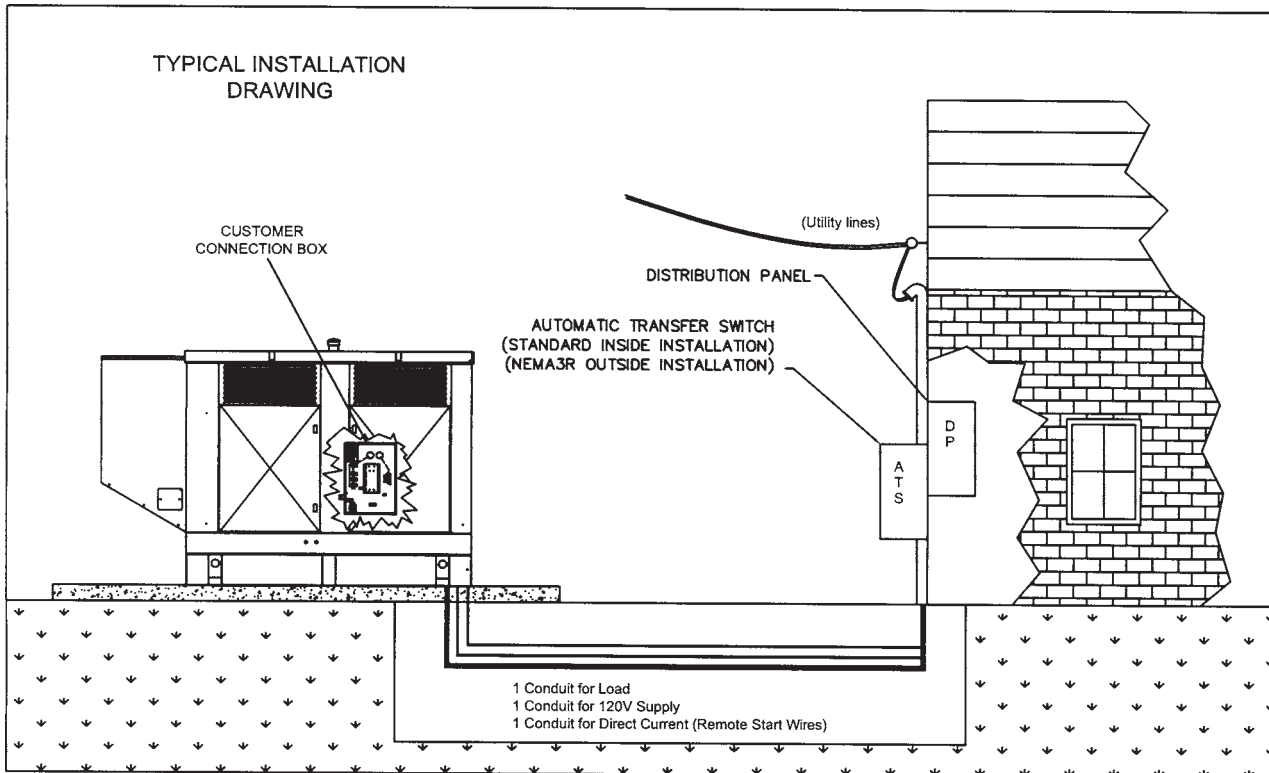

ratings. Plans for installation should be prepared with proper attention to mechanical and electrical engineering detail to assure a satisfactory system installation.

The information in this manual is offered only as a guide to finalizing your installation plans.

**** NOTICE ****

For full service switching of the entire load, the ATS must be 'SE' (Service Entrance) rated or must have a properly rated fusible disconnect installed before the ATS to protect the contacts.

ENGINE GENERATOR SET MOUNTING

The unit's main frame must be bolted solidly to a 4 to 6 inch thick cement pad. The engine-generator is mounted on a sub-frame which is attached with special shock mounts to the main frame. This allows the engine-generator free movement without affecting the control panel which is mounted on the main frame.

Do not shock mount the main frame. Engine vibration will be transmitted to the control panel causing erroneous start/stop cycles and premature control failure.

The unit should be mounted to allow for ample working room around it. A general rule to follow is five (5) feet of clearance on all sides. (Code NFPA 37)

FUEL INSTALLATION

The fuel supply should be as close to the engine as possible. This will reduce the installation cost of fuel runs and minimize line losses. The diesel fuel supply should be no more than 3 feet below the fuel inlet on the pump. If your fuel supply is lower than three feet you may have to install an additional lift pump to bring the fuel up to the mechanical fuel pump on the engine.

The information in this manual is offered to assist you in providing the proper fuel for your engine. However, this information is only provided to inform you of the engine's requirements and assist in making you aware of the decisions you must make. In no case should the instructions or information provided be interpreted to conflict with any local, state or national codes. If in doubt, always consult your local fire marshal or fuel supplier.

INSTALLING THE FUEL LINE

Engine generator sets are properly adjusted before they leave the factory. Connecting a fuel supply with adequate supply volume is critical to reliable operation. Diesel units with optional base mounted fuel tanks are pre-plumbed to the mechanical fuel pump on the engine.

Open skid mounted Diesel units are often supplied with capped inlet and return lines. The use of a suitable customer supplied flexible fuel line is essential between the engine and fuel supply to provide a vibration break between your fuel supply and the engine.

**** **WARNING** ****

FIRE DANGER - Connecting rigid fuel line (i.e. steel or copper line) directly to the inlet fuel filter or fuel pump may cause the fuel line to crack during operation creating a serious fire hazard.

LUBRICATION

Before starting the engine, check the oil level in the crankcase. If it is low, refill to the full mark with the proper weight/grade of oil as recommended by the engine manufacturer's maintenance instructions. The necessity of using the correct oil, and keeping the crankcase full cannot be over emphasized. Failure to use the proper oil and keep the crankcase properly filled will cause excessive engine wear and shorten its useful life.

COOLANT

Before starting the engine, check the coolant level in the radiator. If it is low, refill as specified in the engine manufacturer's maintenance instructions. The radiator should be filled to about 1 inch below the filler neck. For additional information on engine coolant requirements see engine manufacturer's maintenance instructions.

INSTALLING THE BATTERY

**** **CAUTION** ****

In the following battery installation procedure, check to be sure the DSE7X10 is in the "stop" position. This should be your last step before initial start-up.

A customer supplied twelve-volt battery is required to complete the installation; 24 volt systems require 2 batteries. Installation of the highest CCA rated battery, within the correct BCI group, will increase cold weather starting performance. *Gel batteries should not be used* with the battery tender installed in the generator enclosure.

See the specification listing in appendix 1 for the correct battery size and minimum CCA rating for the different models.

Installation and servicing of batteries must be performed or supervised only by personnel knowledgeable of batteries and the required precautions. Keep unauthorized personnel away from batteries.

When installing or replacing batteries, use the proper group/size **starting** battery. The battery should be a Maintenance Free lead acid design. Deep cycle batteries will not work for this application.

CAUTION – PERSONAL DANGER

CAUTION - NEVER dispose of a battery in a fire. The battery is capable of exploding.

CAUTION -DO NOT open or mutilate the battery. Released electrolyte is known to be harmful to the skin and eyes and to be very toxic.

These engine generator sets are all **NEGATIVE** ground. Be very careful not to connect the battery in reverse polarity, as this may short circuit the battery charging system on the engine.

CAUTION – A battery presents a risk of electrical shock and high short circuit current. The following precautions must be observed when working with batteries:

1. Remove watches, rings and other metal objects.
2. Use tools with insulated handles.
3. Check both the battery cable ends and the battery posts to be sure they are free of corrosion.
3. Always connect the battery positive cable first and then connect the battery negative cable. When removing the battery cables from the battery reverse the procedure, disconnect the negative cable first and then the positive cable.
4. Be sure all connections are tight and coat the terminals and cable ends with dielectric grease.

WARNING – The electrolyte is a diluted sulfuric acid that is harmful to the skin and eyes. It is electrically conductive and corrosive. The following precautions must always be taken:

- * Always wear full eye protection and protective clothing
- * Where electrolyte contacts the skin, wash off immediately with water
- * If electrolyte contacts the eyes, flush thoroughly and immediately with water and seek immediate medical attention
- * Spilled electrolyte is to be washed down with an acid neutralizing agent. A common practice is to use a solution of one pound of bicarbonate of soda (baking soda) to one gallon of water. The bicarbonate of soda solution is to be added until the evidence of reaction, foaming, has ceased. The resulting liquid is to be flushed with water and the area dried.

DANGER – Explosive Fire Risk

- * Never smoke when near batteries
- * Do not cause a flame or spark in the battery area
- * Always discharge static electricity from your body before touching batteries by first touching a grounded metal surface

SERVICING BATTERIES

Batteries used on these units may, over time, lose water. This is especially true if you are using a trickle charger to maintain your battery. When refilling the battery with water use only distilled water. Tap water will shorten the service life of the battery.

Never fill the battery above the fill line. Over filling above the upper level line may cause the electrolyte to overflow, resulting in corrosion to the engine or nearby parts. Immediately wash off any spilled electrolyte following the procedure above.

NOTE: Always make sure that a new battery is fully charged before installing it on a generator set. Failure to do so can cause damage to the engine control module in the generator set.

All connections must be clean and tight. Check the electrolyte (fluid) in the battery periodically to be sure it is above the plates. Never allow the battery to remain in a discharged condition.

CONNECTING THE BATTERY CHARGER & BLOCKHEATER

A three-stage battery charger is provided standard for all 12 volt standby systems. The standard charger is a Automatic Battery Charger & Maintainer. This Charger has three rates of charging. During the first stage, know as BULK Charging, the charging current is limited to 2 Amps at a voltage of up to 14.5 volts. The green LED will blink during this stage. During stage two, know as ABSORPTION Charging, the charging voltage is held at 14.5 volts and the charging rate gradually reduces the amount of current (amps) flowing to the battery. The green LED will also blink during this stage. Stage three is called MAINTENANCE Charging. During this stage the voltage will drop to 13.3 volts and the charge rate will drop to as low as .1 amps. This keeps your batteries in a fully charged condition without over charging them. During this stage the green LED is constantly lit.

This charger is mounted on the back side of the generator cabinet and plugged into the receptacle mounted in the AC connection cabinet.

All 24 volt battery chargers and option 12 volt chargers will have a cord on them that you can plug into the receptacle on the side of the connection box or depending on size they may require hard wiring in the terminal block in the bottom left of the connection box.

**** NOTICE ****

The trickle charger is not intended to recharge a battery which has become completely discharged. It is designed to produce just enough current to maintain a fully charged battery.

The battery tender receptacle is to be powered by a GFCI circuit and installed in accordance with the United States National Electric Code. It is suggested that this circuit be fused for 20 -30 amps, depending on blockheater requirements. Then both the battery charger and the block heater can be connected to the same circuit. A 120 volt duplex receptacle is mounted on the generator along the side circuit breaker panel, for a 20 amp circuit and terminal blocks are provided for heavier circuits.

The engine blockheater installed on this unit should also be plugged in this receptacle. The block heater is thermostatically controlled and when plugged in will maintain the engine coolant temperature between 100 and 120 degrees F.

MOUNTING THE AUTOMATIC TRANSFER SWITCH (A.T.S.)

******* WARNING *******

FIRE HAZARD - All wiring must be done by a licensed electrician, and must conform to the National Electrical Code and comply with all state and local codes and regulations. Check with the local authorities before proceeding!

INSTALLATION NOTES

Because of the many different types of service, feeder, and distribution equipment, no specific wiring instructions can be provided. It is recommended that only copper wire be used. In all cases it is essential that while the load is connected to the generator, there can be absolutely no feedback from the generator to the power line or the power line to the generator. When properly installed, the normal A.T.S. Control and safety systems will eliminate all paths for feedback.

To wire the automatic transfer switch into the existing wiring, first determine which circuits will be on the emergency load circuit. If the entire load is to be transferred, the transfer switch can be wired in directly after the watt-hour meter and the service entrance, providing the service entrance ampere rating is within the transfer switch's rated capability.

If only specific circuits are to be powered under emergency power failure conditions, an additional distribution panel designated "emergency distribution panel" must be installed.

All selected emergency circuits are removed from main distribution panels and installed in the emergency distribution panel. The A.T.S. is then installed between the main panel and the emergency distribution panel. Suggested circuits: freezer, refrigerator, furnace, emergency lights, sump pump, emergency outlet circuits, etc. Total running load must not exceed generator rating.

A.C. ELECTRICAL CONNECTIONS

NOTICE - CLASS 1 WIRING METHODS ARE TO BE USED FOR ALL FIELD WIRING CONNECTIONS TO TERMINALS OF A CLASS 2 CIRCUIT

Note: This symbol  always indicates ground where shown.

All wiring must be completed in accordance with the Nation Electric Code as well as any state or local codes.

You must pay particular attention to wire size requirement for the amperage of service you are dealing with. Appendix "2" provides you guidance on wire sizing based on both wire type and amperage. **Wire amperage's have been derated for 40°C ambient temperatures operation.**

A - Neutral Lugs, These neutral lugs are isolated from ground and provided for you to connect your neutral wire from the transfer switch to the generator.

The 1200 amp terminal block lugs on the 300 to 600 kW will handle wire sizes #3/0 to 600 MCM and should be torqued to 28 ft. lbs.

The 1000 amp terminal block lugs on the 130 kW to 250 kW will handle wire sizes #3/0 to 500 MCM and should be torqued to 28 ft. lbs. (Rated for 900 AMP for AL)

The 400 amp terminal block lugs on the 65 & 90 kW will handle wire sizes #1 AWG to 400 MCM and should be torqued to 300 in. lbs.

CUSTOMER CONNECTION BOX FOR BOTH AC & DC CONNECTION 10 kW THROUGH 125 kW

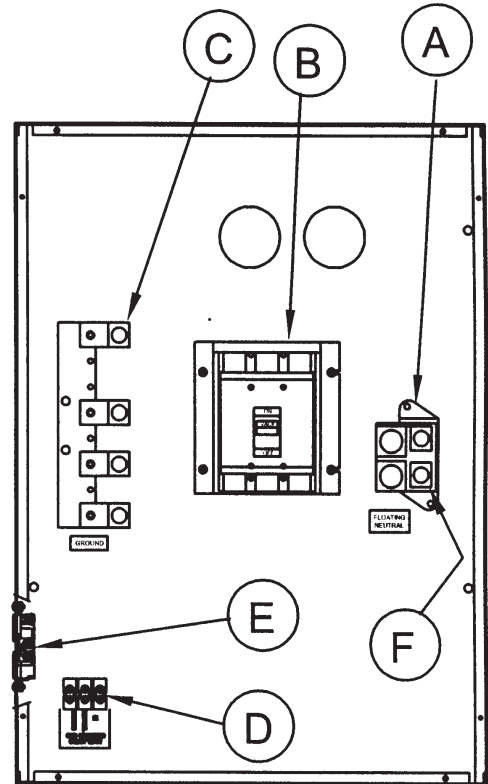

CUSTOMER CONNECTION BOX FOR BOTH AC & DC CONNECTION 150 kW THROUGH 350 kW

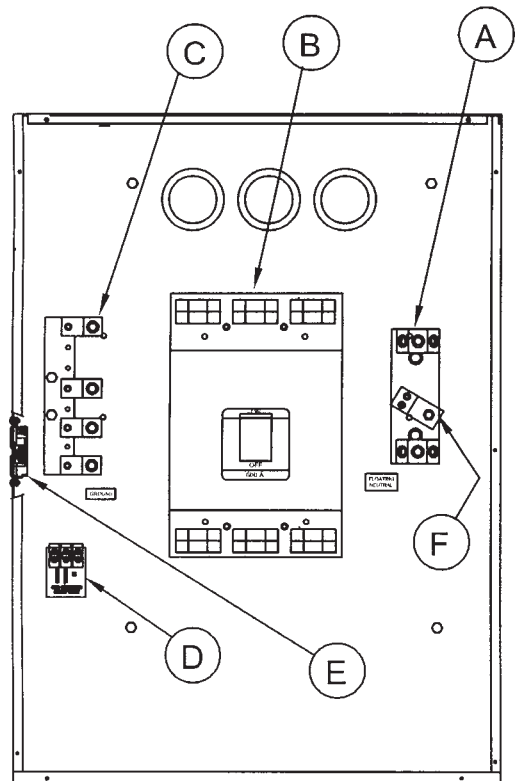

The 225 amp terminal block lugs on the 20 kW to 45 kW will accommodate #4 AWG to 300 MCM and should be torqued to 250 in. lbs.

B - Generator Circuit Breaker, This circuit breaker provides overload protection for the generator. Your power feeds from the transfer switch will connect to the bottom lugs on the circuit breaker. The generator power feeds have already been wired into the upper lugs.

Please refer to the circuit breaker installed on your unit for breaker lug capacities and proper torque specifications.

To select the proper conductor size between the Generator and the ATS, first look your model up in Table 1 of Appendix "A" for your generator amperage. Then refer to Appendix "2" for guidance on wire sizing based on both wire type and amperage. **Wire ampereages have been derated for 40° C ambient temperatures operation.**

For additional information on wire sizing refer to table 310-16 of the National Electrical Code ANSI/NFPA 70.

C - Ground Lug, These ground lugs are bonded to ground and are provided for you to connect your ground wire from the transfer switch to. The lugs on the 65 kW and larger will handle wire sizes #6 AWG to 300 MCM and should be torqued to 21 ft. lbs. The lugs on the 20 & 45 kW will accommodate #10 AWG to 2/0 AWG and should be torqued to 200 in. lbs.

D - 120 VOLT GFCI CIRCUIT TERMINAL BLOCK - These terminals are rated for 85 amps and will handle wire sizes #4 AWG to #18 AWG. They should be torqued to 16 in. lbs. This circuit must be fed from a fused circuit in the distribution panel and provides power for the blockheater and the battery charger.

E - 120 VOLT/20 AMP DUPLEX RECEPTACLE, This convenience receptacle is used on the small units to plug in both the small float charger as well as the blockheater. On some the units with the larger block heater you will have to wire directly into the terminal block.

F - This lug is provided on the neutral terminal block to allow you to run a neutral to ground lead if you are using the generator in a stand alone application. This would be an application where there is not distribution panel and **no other ground to neutral bond** in the wiring system. If a grounding wire is attached here remove the floating neutral label in the panel. **This will not be used when you are wiring a generator and transfer switch into an existing power system.**

 ***** **WARNING** *****

A main line circuit breaker has been provided inside the generator housing. During all wiring installations make sure the breaker is in the OFF position and the generator operation switch is in the OFF position.

 ***** **WARNING** *****

EQUIPMENT DAMAGE - When installing a Three Phase 240 volt system be sure you know which lead is the high voltage "wild" leg (208Volt line to neutral). The generator normally carries the high voltage on the G2 lead.

All wires should be installed in rigid or flexible conduit. (Knock-outs are provided in the control box).

See the manual shipped with the Automatic Transfer Switch for connection locations in the switch. Connections in each switch will vary depending on the type of switch and the manufacturer.

GROUNDING

A grounding lug has been provided on the engine generator set and the generator set must be properly grounded to good earth ground. Generally a 8 foot copper rod driven into the earth will provide a proper earth ground.

D.C. ELECTRICAL CONNECTIONS

All DC connections are completed on the terminal strip just below the engine control. All DC connection **must be run in separate conduit**. You can not mix AC and DC leads in the same conduit. **CONNECTION BOX TERMINALS**

Wire size requirements for each of the connections may vary but terminal lugs should be used for all connections. Torque spec for terminal lugs is 9 in. lbs.

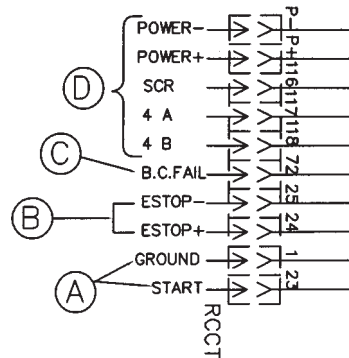

A - Customer Remote Start CONNECTIONS TERMINALS. The two remote start leads from the Automatic Transfer Switch are connected to the two terminals marked 1 & 23. The wire in the terminal labeled #1 is Battery Negative and the wire in the terminal labeled #23 is your Remote Start lead. Closing these two leads together will signal the DSE 7X10 to go into an auto-start mode and start up the engine generator.

Depending on the distance, 14 to 16 gauge stranded wire should be used. It is suggested that these wires be labeled S1 and S23. The terminal blocks are designed to use terminal lugs on all wires and the screws should be torqued to 9.6 in. lbs.

Note: Any relay closure can be used to start and stop this generator. As long as the contact stays closed the engine generator set will continue to run. Once the relay is opened the unit will shut down and remain in the standby mode until the remote start relay is closed again.

B - ESTOP- & ESTOP+. Remote Emergency Stop terminals. These two terminals are shipped with a jumper installed. If your application requires the installation of a Remote Emergency Stop switch, remove the jumper and wire your switch to these terminals. **This unit will not start and run without either the jumper installed or a remote N/C switch installed.**

C - Battery Charger Failure. Battery charger failure relay input from remote battery charger to DSE7X11 controller.

D - Remote Display Panel Interface Terminals. These interface terminals are prewired to allow for the connection of a remote display. This display allows for the remote annunciation of alarms at a location such as a nurses station or a control room. This display can be used to meet the remote annunciation requirements of NFPA 110 standards. *(This feature meets the annunciation requirements in applications requiring NFPA110 level one protection.)*

DC Interconnections to the Automatic Transfer Switch

Two control wires are required between the A.T.S. panel and the generator control terminal box. Depending on the distance, 14 to 16 gauge stranded wire should be used. These wires should be labeled S1 (ground) and S23 (start).

 ***** **WARNING** *****

Be sure Engine Generator is in the "OFF" position before you make any DC interconnections.

*******CAUTION*******
Never run the AC and DC wiring in the same conduit.

Zenith ATS

The terminal markings in the Zenith ATS are marked "X1" and "X2". The wire labeled "Start 1" is routed to start contact "X1" and the wire labeled "Start 23" is routed to start contact "X2"

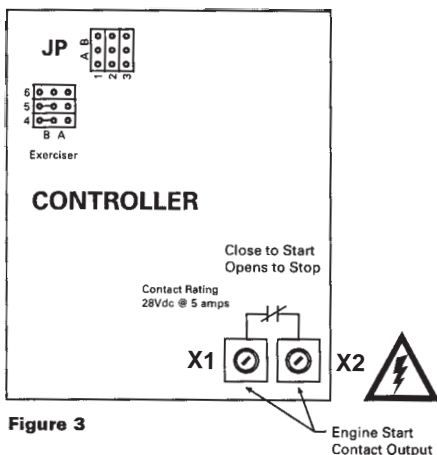

ASCO 165 UL SWITCH

Your DC connection points in the ASCO 165 ATS are terminals "4" and "5" on the interface terminal block.

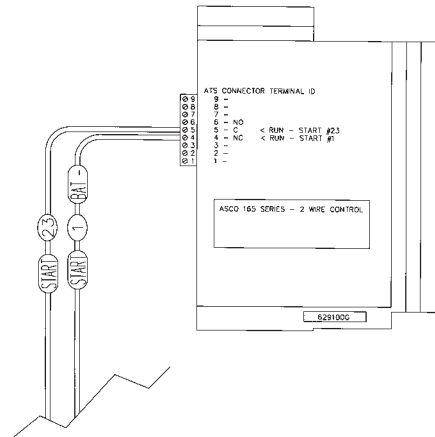

ASCO 300 UL SWITCH

Your DC connection points in the ASCO 300 ATS are terminals "14" and "15". Depending on the size of the switch they are located in different locations.

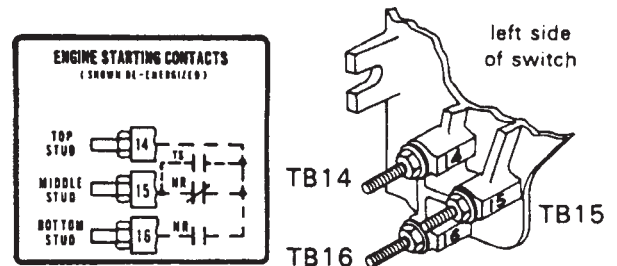
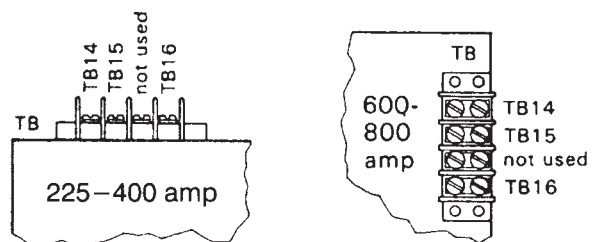

Figure 1-4. Engine starting contact label and location for 30 - 200 amp switches.



INITIAL START UP

***** WARNING *****

EQUIPMENT DAMAGE - DO NOT jump start these engine generator sets. Starting these units on a low battery or jump starting them will cause damage to the engine control module.

Use the following check list to verify correct installation before starting the engine:

1. Engine oil. Fill as required with proper grade/qty.
2. Engine coolant. Fill as required with proper mixture.
3. Unit mounting base properly bolted down.
4. Clearance for service and maintenance on all sides.
5. Proper fuel line material and size.
6. All fuel line connections tight.
7. Battery connections clean and tight.
8. Battery fully charged.
9. All AC and DC wiring installed and properly protected.

After completing the above checklist, the engine-generator set is ready for the initial start-up test.

STARTING PROCEDURE

MANUAL MODE

***** WARNING *****

EQUIPMENT DAMAGE - BEFORE ATTEMPTING TO START THIS UNIT COMPLETE YOUR PRESTART CHECKLIST AND INSURE THE GENERATOR MAINLINE CIRCUIT BREAKER IS IN THE PROPER POSITION PRIOR TO STARTING. STARTING THIS UNIT WITHOUT IT PROPERLY CONNECTED CAN CAUSE SERIOUS PERSONAL INJURY OR EQUIPMENT DAMAGE.

1. Depress the manual mode button on the control panel. The small LED light next to it should come on.
2. Press the start button- The DSE7X10 will send a start signal to the ECU on the engine. The engine ECU will then energize the fuel solenoid and start the cranking cycle (10 seconds on and 10 seconds off).

NOTE: There is no start delay in this mode of operation.

If the engine fails to start during this cranking period the starter motor is disengaged and goes into a rest mode after which a second attempt is made to start the engine. Should this sequence continue through 3 cranking cycles the start sequence will be stopped and the display will show 'FAILED TO START'.

All engine functions are controlled by the ECU on the engine. The ECU on the engine will send information signals to the DSE7X10 via the CAN connections to indicate oil pressure, water temperature, etc for the display on the engine control. All shutdown functions are also controlled by the ECU on the engine what you see displayed on the DSE7X10 display is what is happening inside the ECU on the engine.

The AC output readings displayed on the DSE7X10 are collected through the AC interface harness wired in the generator control box. An shutdowns related to the AC output are not a function of the engine ECU but are based on information collected in the DSE7X10 via this AC harness.

4. During manual operation the load will not normally be applied to the generator. But caution must be used, if the line power should fail or be turn off to the transfer switch during manual operation the load may be applied to the generator.

With the engine running smoothly check the no load voltage and frequency on the digital display. The voltage should be 208/240/480 AC depending on which model you have and a frequency of 59.5 To 60.5 hertz (Hz).

If you have the proper voltage at the generator the next step is to check the voltage at the generator terminals in the Automatic Transfer Switch. The voltage between the G1 and the G3 terminals should be the same as it was on the generator front panel. The voltage should also be checked between the hot terminals (G1 and G3) and the G-N to be certain of a balanced voltage output and a solid neutral connection. The voltage between G1 and G-N should be about 120 volts AC (277 on 480 units). The same approximate voltage should be found between terminals G3 and G-N (120 volts AC).

On three phase panels the G2 voltage level should also be checked. ON 240 VOLT (DELTA) SYSTEMS BE SURE YOU KNOW WHERE THE HIGH VOLTAGE "WILD" LEG IS. IT MUST BE IN THE SAME LOCATION ON THE LINE SIDE AS IT IS ON THE GENERATOR SIDE. (i.e. if it's on L-3 on the line side it must be on G-3 on the generator side.

** Notice **

If for any reason during the check out procedure the voltage and frequency are not correct, depress the STOP/RESET button and correct the trouble before proceeding.

5. Stopping – There are two ways to stop the unit when it is in the manual mode. Pressing the STOP/RESET button will stop the unit immediately. Pressing the AUTO mode button will stop the unit but only after the cool down timers have timed out and there is no remote start signal being sent to the unit.

AUTO MODE

To activate the automatic start mode you will just need to depress the AUTO button, the LED indicator beside the button confirms that the unit is in automatic start mode.

To test the automatic start Transfer Switches follow the instruction in the operator's manual you received with your transfer switch. If you get a fault light during the initial start up or prior to start up it is most likely a false warning light. Simply reset the ATS and start over.

Once you have completed testing of the ATS, be sure you ALWAYS leave the system in standby mode unless servicing the unit. For standby operation, press the AUTO button on the front of the engine control. The green light should light up next the AUTO button.

SETTING THE EXERCISER CIRCUIT

For all ATS see the instruction manual shipped with the ATS for instruction on setting the exercise circuit in your ATS.

TROUBLESHOOTING TABLES

Note: Before doing any troubleshooting, check the digital display on the DSE7X10. Normally it will tell why the unit has failed. This will shorten your troubleshooting time and in many cases prevent the replacement of parts that may not be defective.

UNIT WILL NOT CRANK WHEN THE POWER FAILS.

1. Digital Genset Controller not in "AUTO"
2. Transfer control switch not in "AUTOMATIC" position.
3. Incorrect wiring between transfer switch and generator.
4. Defective control relay in the transfer switch.
5. Fuse (s) blown in the Digital Genset Controller.
6. Defective Digital Genset Controller
7. Loose or dirty battery terminals.
8. Defective starter.
9. Defective start solenoid.
10. Dead Battery

ENGINE WILL NOT CRANK WITH GENERATOR RUN PUSH-BUTTON DEPRESSED.

1. Battery dead.
2. Blown DC fuses on the Digital Genset Controller tripped.
3. Defective Digital Genset Controller.
4. Loose or dirty battery terminals.
5. Defective "Run/Auto" switch on generator.
6. Defective starter.
7. Defective start solenoid.
8. Locked up engine genset.

ENGINE CRANKS BUT WILL NOT START

1. Improper fuel delivery to the unit.
2. Fuel supply shut off.
3. Fuel tank empty.
4. Air in the injection system.
5. Engine fuel rack has not opened.
6. Defective CANBus on the engine

ENGINE STARTS AND THEN STOPS AND ALARM LIGHT COMES ON

1. Engine is low on oil.
2. Engine has high water temperature.
3. Engine has overspeed.
4. Engine has gone into overcrank.
5. No output from AC generator.
6. Loss of speed signal.
7. Loss of run signal.

ENGINE WILL NOT COME UP TO SPEED AFTER IT STARTS

1. Insufficient fuel volume getting to the unit.
 - a. Too small of fuel line.
 - b. Fuel racks not opened properly
2. Governor is defective.
3. AC short in generator components.

ATS PANEL WILL NOT TRANSFER TO EMERGENCY SUPPLY (GENERATOR)

1. No AC generator output from generator.
2. Defective ATS control board. See applicable transfer switch manual .
3. Circuit breaker between generator and transfer switch is either open or defective.

ATS PANEL WILL NOT RETRANSFER TO NORMAL POWER

1. Proper normal line power not available at line terminals in ATS panel.
2. Defective ATS control board. See applicable transfer switch manual .

NO AC OUTPUT FROM GENERATOR

1. Defective diode.
2. Defective voltage regulator.
3. Defective rotor.
4. Defective stator.
5. Defective exciter rotor.
6. Defective exciter stator.
7. AC short in the output leads.
8. Defective field circuit breaker.
9. Wiring error

APPENDIX

UNIT SPECIFICATIONS	PAGE 15
ENGINE MODEL NUMBER	PAGE 15
BATTERY REQUIREMENTS	PAGE 15
FULL LOAD FUEL REQUIREMENTS	PAGE 15
WIRE SIZING TABLE	PAGE 16
WIRING DIAGRAM CROSS REFERENCE	
BY MODEL NUMBER	PAGE 17
GENERATOR AC CONNECTION DIAGRAM	
120/240 VOLT SINGLE PHASE	PAGE 18
120/240 VOLT THREE PHASE	PAGE 18
120/208 VOLT THREE PHASE	PAGE 19
277/480 VOLT THREE PHASE	PAGE 19
VOLTAGE REGULATOR CONNECTION	PAGE 14
GENERATOR CONTROL PANEL WIRING	PAGE 20
ENGINE SCHEMATIC	PAGE 21
GENERATOR CROSS REFERENCE	PAGE 24
WARRANTY STATEMENT	PAGE 25

VOLTAGE REGULATOR WIRING THREE PHASE AND SINGLE PHASE

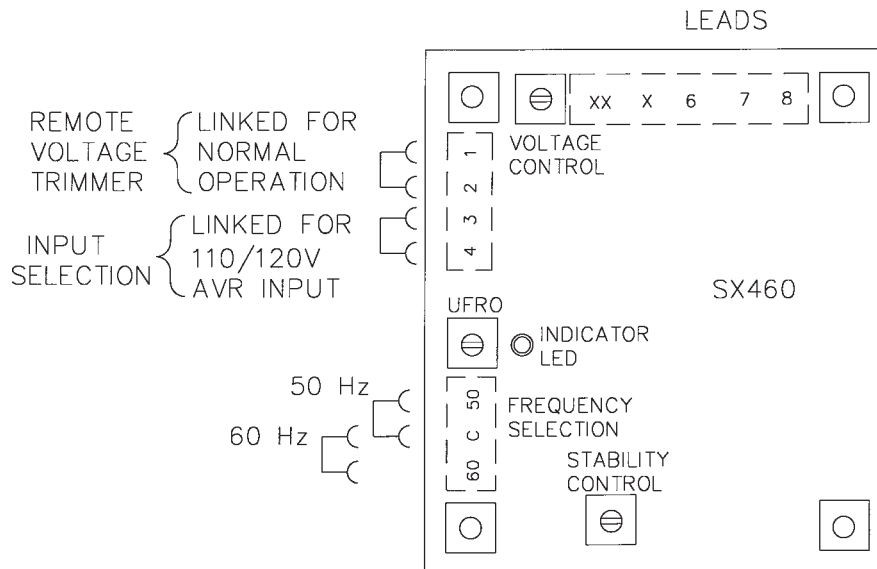

APPENDIX 1

SPECIFICATIONS TABLES

<u>MODEL</u>	<u>WATTS</u>	<u>VOLTS</u>	<u>PF</u>	<u>AMP</u>	<u>HZ</u>	<u>PH</u>	<u>ENGINE</u>	<u>ENGINE</u>	<u>BATTERY</u>	<u>FULL LOAD</u>
DR4514-A	45,000	120/240	1.0	187	60	1	IVECO NEF45 AMI	12 VOLTS	24/650	2.8 GAL
DR4514-D	45,000	120/208	0.8	156	60	3	IVECO NEF45 AMI	12 VOLTS	24/650	2.8 GAL
DR4514-J	45,000	120/240	0.8	135	60	3	IVECO NEF45 AMI	12 VOLTS	24/650	2.8 GAL
DR4514-L	45,000	277/480	0.8	68	60	3	IVECO NEF45 AMI	12 VOLTS	24/350	2.8 GAL
DR6514-A	65,000	120/240	1.0	270	60	1	IVECO NEF45 SM2	12 VOLTS	24/650	5.2 GAL
DR6514-D	65,000	120/208	0.8	225	60	3	IVECO NEF45 SM2	12 VOLTS	24/650	5.2 GAL
DR6514-J	65,000	120/240	0.8	195	60	3	IVECO NEF45 SM2	12 VOLTS	24/650	5.2 GAL
DR6514-L	65,000	277/480	0.8	97	60	3	IVECO NEF45 SM2	12 VOLTS	24/650	5.2 GAL
DR9014-A	90,000	120/240	1.0	375	60	1	IVECO NEF45 TM1X	12 VOLTS	31/900	6.8 GAL
DR9014-D	90,000	120/208	0.8	312	60	3	IVECO NEF45 TM1X	12 VOLTS	31/900	6.8 GAL
DR9014-J	90,000	120/240	0.8	270	60	3	IVECO NEF45 TM1X	12 VOLTS	31/900	6.8 GAL
DR9014-L	90,000	277/480	0.8	135	60	3	IVECO NEF45 TM1X	12 VOLTS	31/900	6.8 GAL
DR10014-A	100,000	120/240	1.0	416	60	1	IVECO NEF67 TE2X	12 VOLTS	31/900	7.7 GAL
DR10014-D	105,000	120/208	0.8	364	60	3	IVECO NEF67 TE2X	12 VOLTS	31/900	7.7 GAL
DR10014-J	105,000	120/240	0.8	315	60	3	IVECO NEF67 TE2X	12 VOLTS	31/900	7.7 GAL
DR10014-L	110,000	277/480	0.8	172	60	3	IVECO NEF67 TE2X	12 VOLTS	31/900	7.7 GAL
DR100D4-A	100,000	120/240	1.0	417	60	1	DEUTZ BF4M1013FC	12 VOLTS	31/900	8.1 GAL
DR100D4-D	100,000	120/208	0.8	347	60	3	DEUTZ BF4M1013FC	12 VOLTS	31/900	8.1 GAL
DR100D4-J	100,000	120/240	0.8	301	60	3	DEUTZ BF4M1013FC	12 VOLTS	31/900	8.1 GAL
DR100D4-L	100,000	277/480	0.8	150	60	3	DEUTZ BF4M1013FC	12 VOLTS	31/900	8.1 GAL
DR13014-A	130,000	120/240	1.0	541	60	1	IVECO NEF67 TE2X	12 VOLTS	31/900	8.9 GAL
DR13014-D	130,000	120/208	0.8	451	60	3	IVECO NEF67 TE2X	12 VOLTS	31/900	8.9 GAL
DR13014-J	130,000	120/240	0.8	390	60	3	IVECO NEF67 TE2X	12 VOLTS	31/900	8.9 GAL
DR13014-L	130,000	277/480	0.8	195	60	3	IVECO NEF67 TE2X	12 VOLTS	31/900	8.9 GAL
DR17514-A	175,000	120/240	1.0	729	60	1	IVECO NEF67 TE2X	12 VOLTS	4D/1200	10.9 GAL
DR17514-D	175,000	120/208	0.8	607	60	3	IVECO NEF67 TE2X	12 VOLTS	4D/1200	10.9 GAL
DR17514-J	175,000	120/240	0.8	526	60	3	IVECO NEF67 TE2X	12 VOLTS	4D/1200	10.9 GAL
DR17514-L	175,000	277/480	0.8	263	60	3	IVECO NEF67 TE2X	12 VOLTS	4D/1200	10.9 GAL
DR200D4-D	200,000	120/208	0.8	607	60	3	DEUTZ BF6M1013FC	12 VOLTS	4D/1200	15.1 GAL
DR200D4-J	200,000	120/240	0.8	526	60	3	DEUTZ BF6M1013FC	12 VOLTS	4D/1200	15.1 GAL
DR200D4-L	200,000	277/480	0.8	263	60	3	DEUTZ BF6M1013FC	12 VOLTS	4D/1200	15.1 GAL
DR25014-D	250,000	120/208	0.8	867	60	3	IVECO CURSOR 87 TE1D	24 VOLTS	(2) 4D/1200	16.3 GAL
DR25014-J	250,000	120/240	0.8	751	60	3	IVECO CURSOR 87 TE1D	24 VOLTS	(2) 4D/1200	16.3 GAL
DR25014-L	250,000	277/480	0.8	375	60	3	IVECO CURSOR 87 TE1D	24 VOLTS	(2) 4D/1200	16.3 GAL
DR30014-D	300,000	120/208	0.8	1040	60	3	IVECO CURSOR 10 TE1D	24 VOLTS	(2) 4D/1200	21.3 GAL
DR30014-J	300,000	120/240	0.8	902	60	3	IVECO CURSOR 10 TE1D	24 VOLTS	(2) 4D/1200	21.3 GAL
DR30014-L	300,000	277/480	0.8	451	60	3	IVECO CURSOR 10 TE1D	24 VOLTS	(2) 4D/1200	21.3 GAL
DR35014-D	350,000	120/208	0.8	1214	60	3	IVECO CURSOR 13 TE2X	24 VOLTS	(2) 4D/1200	22.2 GAL
DR35014-J	350,000	120/240	0.8	1052	60	3	IVECO CURSOR 13 TE2X	24 VOLTS	(2) 4D/1200	22.2 GAL
DR35014-L	350,000	277/480	0.8	526	60	3	IVECO CURSOR 13 TE2X	24 VOLTS	(2) 4D/1200	22.2 GAL

Note: De-rate unit power ratings by 3-1/2 % per 1000 feet elevation above sea level.

APPENDIX 2

The table below is based on Table 310.16 in the National Electric Code 2008 Edition

Allowable ampacities of insulated conductors rated 0 through 2000 volts, 75°C through 90°C. Not more than three current-carrying conductors in Raceway, Cable or Earth (Direct Buried). Adjusted for 40°C (104°F) ambient temperature.

Copper 75°C	Copper 90°C		Aluminum Copper Clad Aluminum 75°C	Aluminum Copper Clad Aluminum 90°C
Wire Type: RHW THHW, THW THWN, XHHW USE, ZW	Wire Type: TBS, SA, SIS FEP, FEPB, MI, RHH RHW-2, THHN THHW, THW-2 XHH, XHHW XHHW-2, ZW-2	SIZE AWG OR kcmil	Wire Type: RHW THHW, THW THWN, XHHW USE	Wire Type: TBS, SA, SIS, THHN THHW, THW-2 THWN-2, RHH RHW-2, USE-2 XHH, XHHW XHHW-2, ZW-2
44	50	8	35	41
57	68	6	44	55
75	86	4	57	68
88	100	3	66	77
101	118	2	79	91
114	137	1	88	105
132	155	1/0	106	123
154	177	2/0	119	137
176	205	3/0	136	159
202	237	4/0	158	187
224	264	250	180	209
251	291	300	202	232
273	319	350	220	255
295	346	400	238	278
334	391	500	273	319
370	432	600	299	350
405	473	700	330	382
418	487	750	339	396
431	505	800	348	410
458	532	900	374	437
480	560	1000	392	455
519	605	1250	427	496
550	642	1500	458	532
572	669	1750	480	560
585	683	2000	493	573

For additional information see table 310.16 of the National Electric Code

APPENDIX 3 WIRING DIAGRAMS CROSS REFERENCE

MODEL	WATTS	VOLTS	PHASE	AC CONNECTION DIAGRAM	DC ENGINE CONTROL	ENGINE CONNECTIONS
DR45I4-A	45,000	120/240	SINGLE	PAGE 18	PAGE 20	PAGE 21
DR45I4-D	45,000	120/208	THREE	PAGE 19	PAGE 20	PAGE 21
DR45I4-J	45,000	120/240	THREE	PAGE 18	PAGE 20	PAGE 21
DR45I4-L	45,000	277/480	THREE	PAGE 19	PAGE 20	PAGE 21
DR65I4-A	65,000	120/240	SINGLE	PAGE 18	PAGE 20	PAGE 21
DR65I4-D	65,000	120/208	THREE	PAGE 19	PAGE 20	PAGE 21
DR65I4-J	65,000	120/240	THREE	PAGE 18	PAGE 20	PAGE 21
DR65I4-L	65,000	277/480	THREE	PAGE 19	PAGE 20	PAGE 21
DR90I4-A	90,000	120/240	SINGLE	PAGE 18	PAGE 20	PAGE 21
DR90I4-D	90,000	120/208	THREE	PAGE 19	PAGE 20	PAGE 21
DR90I4-J	90,000	120/240	THREE	PAGE 18	PAGE 20	PAGE 21
DR90I4-L	90,000	277/480	THREE	PAGE 19	PAGE 20	PAGE 21
DR100I4-A	100,000	120/240	SINGLE	PAGE 18	PAGE 20	PAGE 21
DR100I4-D	105,000	120/208	THREE	PAGE 19	PAGE 20	PAGE 21
DR100I4-J	105,000	120/240	THREE	PAGE 18	PAGE 20	PAGE 21
DR100I4-L	110,000	277/480	THREE	PAGE 19	PAGE 20	PAGE 21
DR100D4-A	100,000	120/240	SINGLE	PAGE 18	PAGE 20	PAGE 21
DR100D4-D	100,000	120/208	THREE	PAGE 19	PAGE 20	PAGE 21
DR100D4-J	100,000	120/240	THREE	PAGE 18	PAGE 20	PAGE 21
DR100D4-L	100,000	277/480	THREE	PAGE 19	PAGE 20	PAGE 21
DR130I4-A	130,000	120/240	SINGLE	PAGE 18	PAGE 20	PAGE 21
DR130I4-D	130,000	120/208	THREE	PAGE 19	PAGE 20	PAGE 21
DR130I4-J	130,000	120/240	THREE	PAGE 18	PAGE 20	PAGE 21
DR130I4-L	130,000	277/480	THREE	PAGE 19	PAGE 20	PAGE 21
DR175I4-A	175,000	120/240	SINGLE	PAGE 18	PAGE 20	PAGE 21
DR175I4-D	175,000	120/208	THREE	PAGE 19	PAGE 20	PAGE 21
DR175I4-J	175,000	120/240	THREE	PAGE 18	PAGE 20	PAGE 21
DR175I4-L	175,000	277/480	THREE	PAGE 19	PAGE 20	PAGE 21
DR200D4-D	200,000	120/208	THREE	PAGE 19	PAGE 20	PAGE 21
DR200D4-J	200,000	120/240	THREE	PAGE 18	PAGE 20	PAGE 21
DR200D4-L	200,000	277/480	THREE	PAGE 19	PAGE 20	PAGE 21
DR250I4-D	250,000	120/208	THREE	PAGE 19	PAGE 20	PAGE 21
DR250I4-J	250,000	120/240	THREE	PAGE 18	PAGE 20	PAGE 21
DR250I4-L	250,000	277/480	THREE	PAGE 19	PAGE 20	PAGE 21
DR300I4-D	300,000	120/208	THREE	PAGE 19	PAGE 20	PAGE 21
DR300I4-J	300,000	120/240	THREE	PAGE 18	PAGE 20	PAGE 21
DR300I4-L	300,000	277/480	THREE	PAGE 19	PAGE 20	PAGE 21
DR350I4-D	350,000	120/208	THREE	PAGE 19	PAGE 20	PAGE 21
DR350I4-J	350,000	120/240	THREE	PAGE 18	PAGE 20	PAGE 21
DR350I4-L	350,000	277/480	THREE	PAGE 19	PAGE 20	PAGE 21

THREE PHASE AC WIRING - DELTA

SINGLE PHASE AC WIRING

SINGLE PHASE
120/240 VOLTS

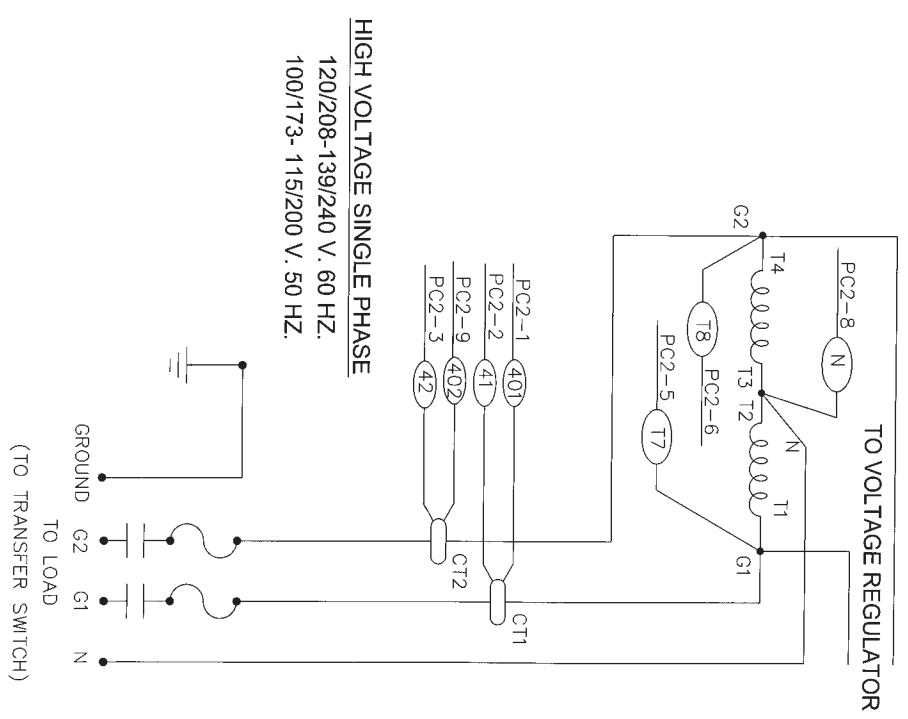

THREE PHASE -DELTA
120/240 VOLTS

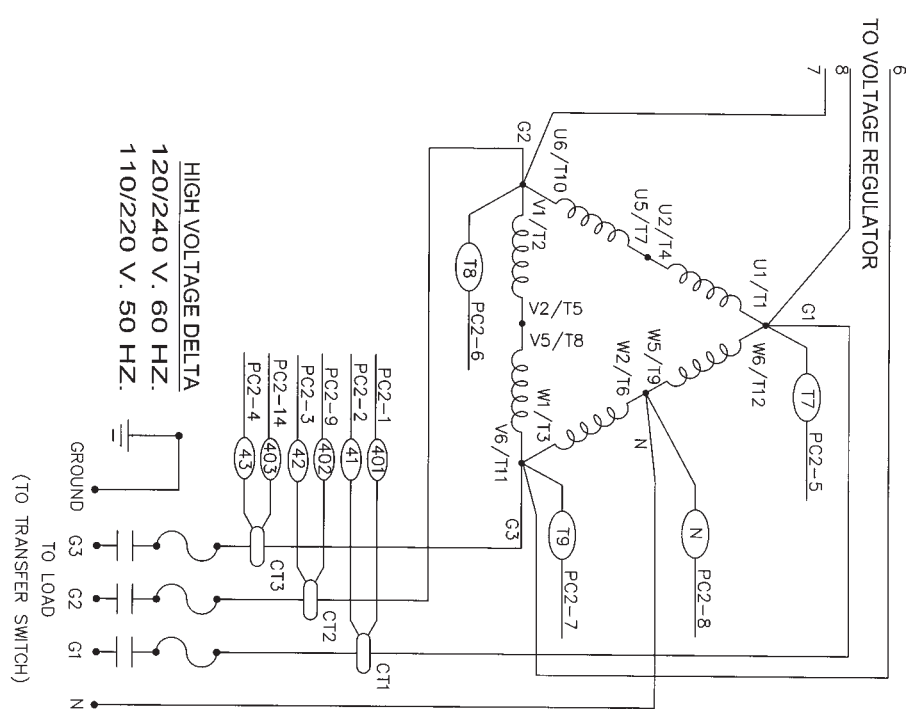

THREE PHASE AC WIRING HIGH AND LOW WYE

**THREE PHASE-HIGH WYE
277/480 VOLTS**

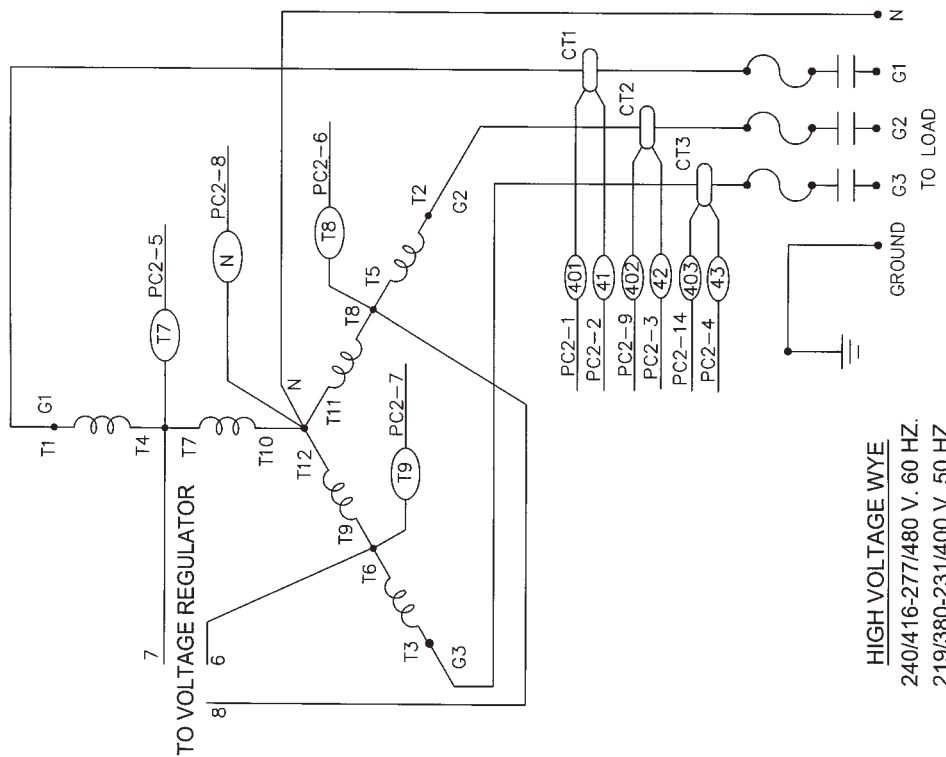

**THREE PHASE-LOW WYE
120/208 VOLTS**

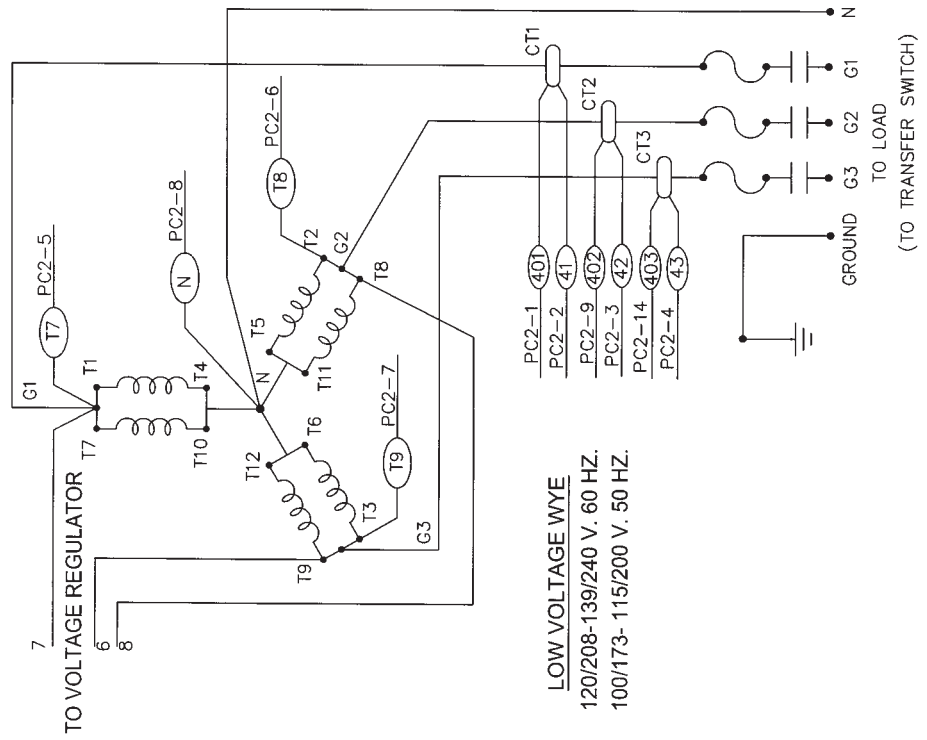

DSE 7X10 ENGINE CONTROL WIRING DIAGRAM ALL MODELS

LEGEND

- ARI AIR FILTER INDICATOR
- ALT ALTERNATOR
- ON1 16 PIN ENGINE CONTROL HARNESS
- ON2 14 PIN GENERATOR HARNESS
- CTS COOLANT TEMPERATURE SENDER
- ESS EMERGENCY STOP SWITCH
- FS FUEL SOLENOID
- GRD GROUND (CHASSIS OR FRAME)
- GP ENGINE GLOW PLUGS
- GPR ENGINE GLOW PLUGS RELAY(50AMP)
- LCL LOW COOLANT LEVEL
- LFL LOW FUEL LEVEL
- OPS OIL PRESSURE SENDER
- RCCT REMOTE CUSTOMER CONNECTION TERMINALS
- RR RUN RELAY
- SM ENGINE STARTER MOTOR
- SS START SOLENOID
- VAR VOLTAGE ADJUSTMENT RHEOSTAT
- PR PILOT RELAY
- PS POWER SWITCH
- ESS R EMERGENCY STOP RELAY

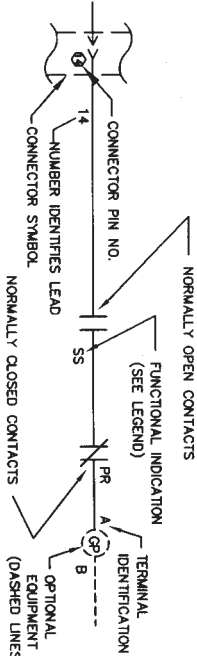
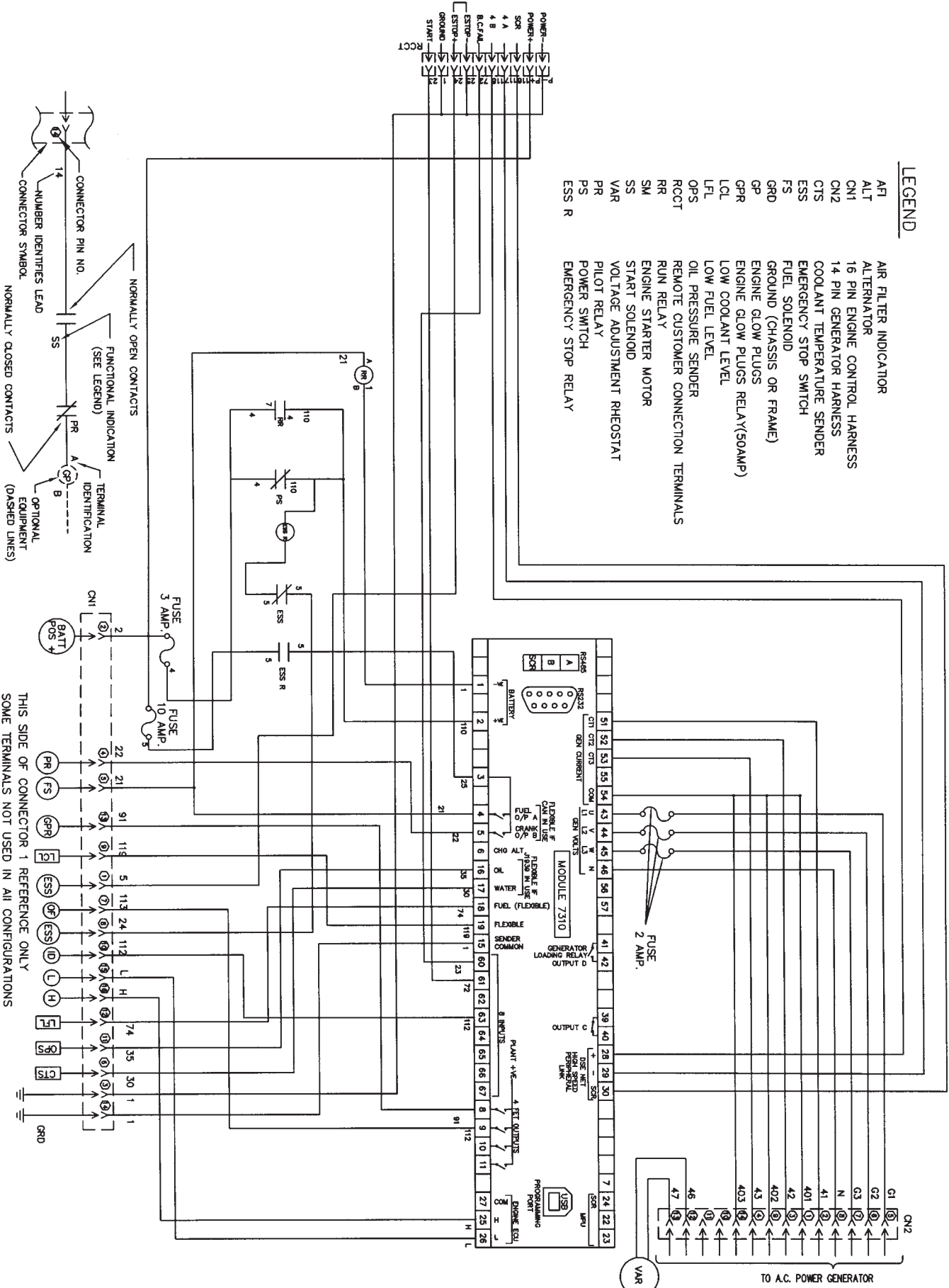

THIS SIDE OF CONNECTOR 1 REFERENCE ONLY
SOME TERMINALS NOT USED IN ALL CONFIGURATIONS

ENGINE SCHEMATIC DR45I4, DR65I4, DR100I4, DR130I4

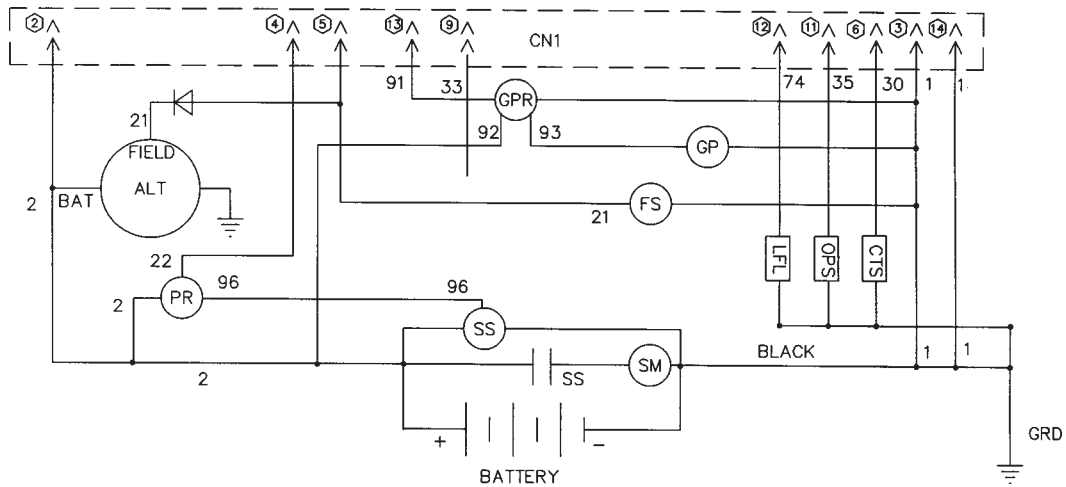

ENGINE SCHEMATIC DR100D4 & DR200D4

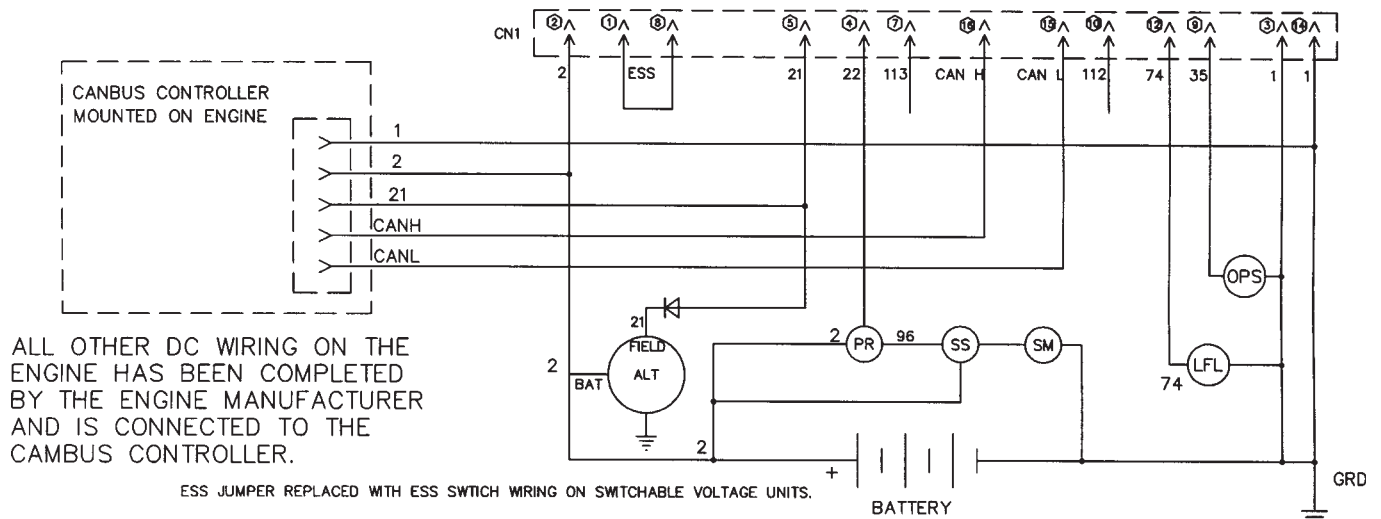

ENGINE SCHEMATIC DR175I4, DR250I4, DR300I4, DR350I44M

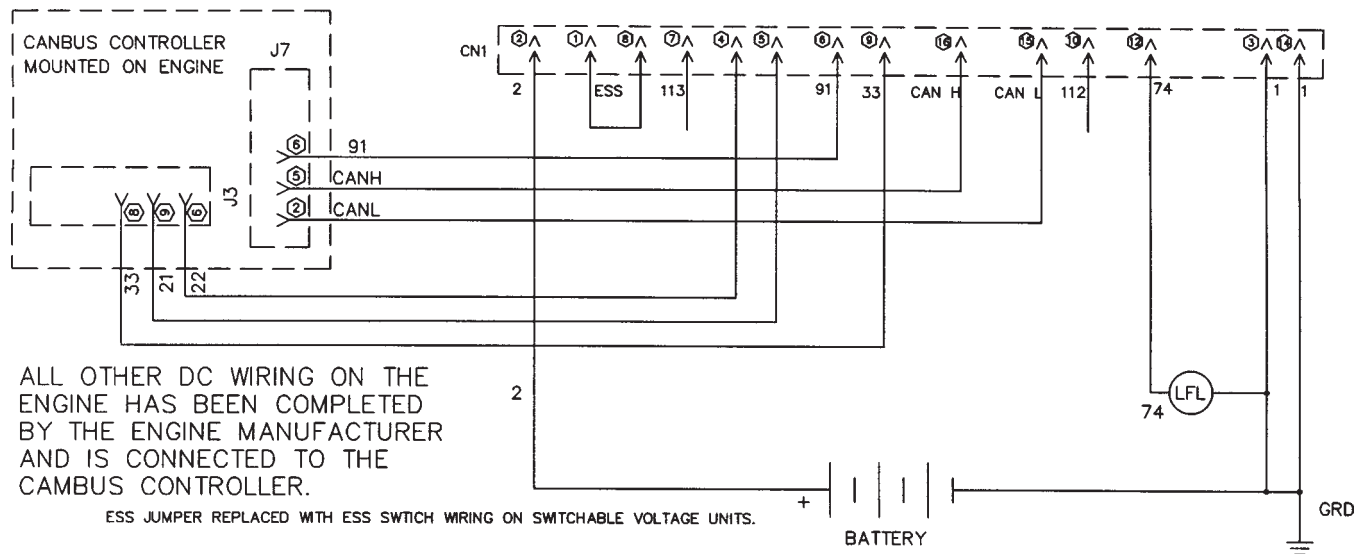

PAGE LEFT BLANK
FOR FUTURE USE

PAGE LEFT BLANK
FOR FUTURE USE

APPENDIX 4

GENERATOR CROSS REFERENCE

MODEL	BASE P/N	VOLTS	PHASE	WINCO P/N	NEWAGE MODEL #	WINDING GROUP	GENERATOR LEADS
DR45I4-A	351907-1	120/240	SINGLE	350003-731	UCI224E	6	4
DR45I4-D	351907-2	120/208	THREE	350003-702	UCI224D	311	12
DR45I4-J	351907-2	120/240	THREE	350003-702	UCI224D	311	12
DR45I4-L	351907-2	277/480	THREE	350003-702	UCI224D	311	12
DR65I4-A	351924-1	120/240	SINGLE	350003-751	UCI224G	6	4
DR65I4-D	351924-2	120/208	THREE	35000-704	UCI224F	311	12
DR65I4-J	351924-2	120/240	THREE	35000-704	UCI224F	311	12
DR65I4-L	351924-2	277/480	THREE	35000-704	UCI224F	311	12
DR90I4-A	351914-1	120/240	SINGLE	350004-711	UCI274C	6	4
DR90I4-D	351914-2	120/208	THREE	350004-701	UCI274C	311	12
DR90I4-J	351914-2	120/240	THREE	350004-701	UCI274C	311	12
DR90I4-L	351914-2	277/480	THREE	350004-701	UCI274C	311	12
DR100I4-A	455100-100	120/240	SINGLE	350004-721	UCI274D	6	4
DR100I4-D	455100-100	120/208	THREE	350004-702	UCI274D	311	12
DR100I4-J	455100-100	120/240	THREE	350004-702	UCI274D	311	12
DR100I4-L	455100-100	277/480	THREE	350004-702	UCI274D	311	12
DR100D4-A	351964-	120/240	SINGLE	350004-421	UCI274D	6	4
DR100D4-D	351964-5	120/208	THREE	350004-702	UCI274D	311	12
DR100D4-J	351964-5	120/240	THREE	350004-702	UCI274D	311	12
DR100D4-L	351964-5	277/480	THREE	350004-702	UCI274D	311	12
DR130I4-A	351949-1	120/240	SINGLE	350004-101	UCI274F	6	4
DR130I4-D	351949-0	120/208	THREE	350004-710	UCI274F	311	12
DR130I4-J	351949-0	120/240	THREE	350004-710	UCI274F	311	12
DR130I4-L	351949-0	277/480	THREE	350004-710	UCI274F	311	12
DR175I4-A	351955-1	120/240	SINGLE	350004-106	UCI274H	6	4
DR175I4-D	351955-0	120/208	THREE	350004-105	UCI274H	311	12
DR175I4-J	351955-0	120/240	THREE	350004-105	UCI274H	311	12
DR175I4-L	351955-0	277/480	THREE	350004-105	UCI274H	311	12
DR200D4-D	351973-1	120/208	THREE	350004-117	UCI274J	311	12
DR200D4-J	351973-1	120/240	THREE	350004-117	UCI274J	311	12
DR200D4-L	351973-1	277/480	THREE	350004-117	UCI274J	311	12
DR250I4-D	351937-1	120/208	THREE	350031-2	HCI434D	311	12
DR250I4-J	351937-1	120/240	THREE	350031-2	HCI434D	311	12
DR250I4-L	351937-1	277/480	THREE	350031-2	HCI434D	311	12
DR300I4-D	351943-1	120/208	THREE	350031-3	HCI434E	311	12
DR300I4-J	351943-1	120/240	THREE	350031-3	HCI434E	311	12
DR300I4-L	351943-1	277/480	THREE	350031-3	HCI434E	311	12
DR350I4-D	351957-2	120/208	THREE	350037-7	HCI434F	311	12
DR350I4-J	351957-2	120/240	THREE	350037-7	HCI434F	311	12
DR350I4-L	351957-1	277/480	THREE	350031-3	HCI343E	311	12



Limited Warranty

WINPOWER, Incorporated warrants to the original purchaser for 12 months or 1000 hours which ever occurs first, that goods manufactured or supplied by it will be free from defects in workmanship and material, provided such goods are installed, operated and maintained in accordance with WINPOWER written instructions.

WINPOWER's sole liability, and Purchaser's sole remedy for a failure under this warranty, shall be limited to the repair of the product. At WINPOWER's option, material found to be defective in material or workmanship under normal use and service will be repaired or replaced. For warranty service, return the product within 12 months or 1000 hours which ever occurs first from the date of purchase, transportation charges prepaid, to your nearest WINPOWER Authorized Service Center or to WINPOWER, Inc. at Le Center Minnesota.

THERE IS NO OTHER EXPRESS WARRANTY.

To the extent permitted by law, any and all warranties, including those of merchantability and fitness for a particular purpose, are limited to 12 months or 1000 hours which ever occurs first, from date of purchase. In no event is WINPOWER liable for incidental or consequential damages.

Note: Some states do not allow limitation on the duration of implied warranty and some states do not allow the exclusion or limitation of incidental or consequential damages, so the above limitations may not apply in every instance. This warranty gives you specific legal rights which may vary from state to state.

WINPOWER reserves the right to change or improve its products without incurring any obligations to make such changes or improvement on products purchased previously.

EXCLUSIONS:

WINPOWER does not warrant Engines. Engines are covered exclusively by the warranties of their respective manufacturers, see enclosed warranties.

WINPOWER does not warrant Batteries, or Other Component Parts that are warranted by their respective manufacturers.

WINPOWER does not warrant modifications or alterations which were not made by WINPOWER, Inc.

WINPOWER does not warrant products which have been subjected to misuse and/or negligence or have been involved in an accident.

WINPOWER
A Division of **MT** Dyna Technology Inc
225 S. Cordova
Le Center MN 56057
Phone - 507-357-6707
www:winpowerinc.com