

# WINCO®

## TB2400C TWO-BEARING GENERATOR



# INSTALLATION AND OPERATORS MANUAL

WINCO INC. 225 S. CORDOVA AVE. LE CENTER, MN 56057 507-357-6821  
SERVICE DEPT. 507-357-6831  
[www.wincogen.com](http://www.wincogen.com)

# TABLE OF CONTENTS

## SAVE THESE INSTRUCTIONS

### INTRODUCTION

### SPECIFICATIONS

### SAFETY

IMPORTANT SAFETY INSTRUCTIONS  
ANSI SAFETY DEFINITIONS

### TESTING POLICY

### UNIT CAPABILITIES

GENERATOR CONNECTIONS

### STARTING ELECTRIC MOTORS

### PREPARING THE UNIT

### UNIT INSTALLATION

PLAN THE INSTALLATION  
MOUNTING

### CONNECTING THE LOADS

APPLYING THE LOAD

### TROUBLE SHOOTING CHART

### WIRING SCHEMATIC

### OUTLINE DRAWING

### 12 MONTH LIMITED WARRANTY

2

2

2

2

3

3

4

4

4

5

6

6

7

8

COPY YOUR MODEL AND SERIAL NUMBER HERE

No other WINCO generator has the same serial number as yours.

If you should ever need to contact us on this unit, it will help us to respond to your needs faster.

MODEL \_\_\_\_\_

SERIAL NUMBER \_\_\_\_\_

PURCHASE DATE \_\_\_\_\_

DEALER NAME \_\_\_\_\_

DEALER PHONE # \_\_\_\_\_

## INTRODUCTION

This generator is a 3600 RPM two-bearing, belt-driven, brushless, rotating field design. The generator is self excited and inherently regulated to +/- (plus or minus) 7% - no load to full rated load. It can be operated under any load within its rating without being damaged. The frequency regulation is determined by the sensitivity of the customer supplied prime mover's governor. It is desirable to maintain this speed to within 3 cycles variation (61.5 Hz - 58.5 Hz) no load to full rated load (3690 RPM - 3510 RPM)

## SPECIFICATIONS

|                  |                       |
|------------------|-----------------------|
| Surge Watts      | 2,400                 |
| Continuous Watts | 2,400                 |
| Volts            | 120                   |
| Amps             | 20                    |
| Receptacles      | (1) NEMA 5-20R Duplex |

## SAFETY

### IMPORTANT SAFETY INSTRUCTIONS

#### SAVE THESE INSTRUCTIONS

This manual contains important instructions that should be followed during installation and maintenance of the generator.

Read and understand all instructions in the manual before starting the generator.

This generator has been designed and manufactured to allow safe, reliable performance. Poor maintenance or improper/careless use can result in injury or death. Please read all safety instructions before installation or use. Keep these instructions handy for future reference. Take special note and follow all warnings on the unit labels and in the manual.

## SAVE THESE INSTRUCTIONS

This manual contains important instructions that should be followed during installation and maintenance of the generator. Read and understand all instructions in the manual before starting and operating the generator.

#### USING THIS MANUAL

Congratulations on your choice of a WINCO generator. You have selected a high-quality, precision-engineered generator designed and tested to give you years of satisfactory service.

To get the best performance from your new generator, it is important that you carefully read and follow the operating instructions in this manual.

Should you experience a problem please follow the "Troubleshooting Tables" near the end of this manual. The warranty listed in the manual describes what you can expect from WINCO should you need service assistance in the future.

# ANSI SAFETY DEFINITIONS

## DANGER:

DANGER indicates an imminently hazardous situation which, if not avoided, **will** result in death or serious injury. This signal word is to be limited to the most extreme situations.

## WARNING:

WARNING indicates a potentially hazardous situation which, if not avoided, **could** result in death or serious injury.

## CAUTION:

CAUTION indicates a potentially hazardous situation which, if not avoided, **may** result in minor or moderate injury. It may be used to alert against unsafe practices.

NOTE: CAUTION is also used on the unit labels and in this manual to indicate a situation that could result in serious damage or destruction of the equipment and possible personal injury.

## 1. ELECTRIC SHOCK -

The output voltage present in this equipment can cause a fatal electric shock. This equipment must be operated by a responsible person.

- A. Do not allow anyone to operate the generator without proper instruction.
- B. Guard against electric shock.
- C. Avoid contact with live terminals or receptacles.
- D. Use extreme care if operating this unit in rain or snow.
- E. Use only three-prong grounded plugs and extension cords.
- F. Be sure the unit is properly grounded to an external ground rod driven into the earth.

## 2. FIRE HAZARD -

- A. Keep a fire extinguisher nearby and know its proper use. Fire extinguishers rated ABC by NFPA are appropriate.

## 3. NOISE HAZARD -

Excessive noise is not only tiring, but continual exposure can lead to loss of hearing.

- A. Use hearing protection when working around this equipment for long periods of time.
- B. Keep your neighbors in mind when permanently installing this equipment.

## 4. CLEANLINESS -

Keep the generator and surrounding area clean.

- A. Remove all grease, ice, snow or materials that create slippery conditions around the unit.
- B. Remove any rags or other materials that could create a potential fire hazard.
- C. Carefully clean up any gas or oil spills before starting the unit.

## 5. SERVICING EQUIPMENT -

All service, including the installation or replacement of service parts, **should be performed only by a qualified technician.**

- A. Use only factory approved repair parts.
- B. Do not work on this equipment fatigued.
- C. Use extreme caution when working on electrical components. High output voltages from this equipment can cause serious injury or death.
- D. Installing a generator is not a “do-it-yourself” project. Consult a qualified, licensed electrician or contractor. The installation must comply with all national, state, and local codes.

# TESTING POLICY

Before any generator is shipped from the factory, it is fully checked for performance. The generator is loaded to its full capacity, and the voltage, current, and frequency are carefully checked.

Rated output of generator is based on engineering tests of typical units, and is subject to, and limited by, the temperature, altitude, fuel, and other conditions specified by the manufacturer of applicable engines.

# UNIT CAPABILITIES GENERATOR CONNECTIONS

This generator is designed for 120 Volt alternating current (AC). Two circuit breaker protected outlets are provided for connection to various loads. This generator can be spun in either direction.

Check the appliance or tool nameplates for current and voltage to ensure compatibility. Although a circuit breaker is provided, damage due to overload constitutes abuse and will not be warranted. Refer to the generator nameplates for unit’s capabilities.

The following diagram represents a 2,400 Watt generator. Only 2,400 Watts at 120 Volts (20 Amps) is available from the generator at receptacle A. CAUTION MUST BE EXERCISED TO PREVENT OVERLOADING THE 120 VOLT CIRCUIT.

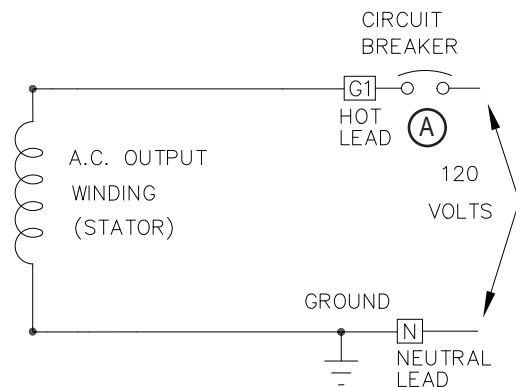

# STARTING ELECTRIC MOTORS

Electric motors require much more current (Amps) to start than to run. Some motors, particularly low-cost split-phase motors, are very hard to start and require 5 to 7 times as much current to start them than to run them. Capacitor motors are easier to start and usually require 2 to 4 times as much current to start them than to run them. Repulsion Induction motors are the easiest to start and require 1 1/2 to 2 1/2 times as much current to start them than to run them.

Most fractional horsepower motors take about the same amount of current to run them whether they are Repulsion Induction (RI), Capacitor (C), or Split-Phase (SP) type. The chart below shows the approximate current required to start and run various types and sizes of 120 Volt, 60 cycle electric motors under average conditions.

| HP  | AMPS RUNNING | STARTING AMPS |          |          |
|-----|--------------|---------------|----------|----------|
|     |              | SP            | CAP      | RI       |
| 1/6 | 3.2          | 16 TO 22      | 6 TO 13  | 5 TO 8   |
| 1/4 | 4.5          | 22 TO 32      | 9 TO 8   | 7 TO 12  |
| 1/3 | 5.2          | 26 TO 35      | 10 TO 21 | 8 TO 17  |
| 1/2 | 7.2          | NOT MADE      | 14 TO 29 | 11 TO 18 |
| 1   | 13.0         | NOT MADE      | 26 TO 52 | 20 TO 33 |

The figures given above are for average load such as a blower or fan. If the electric motor is connected to a hard starting load such as an air compressor, it will require more starting current. If it is connected to a light load, or no load such as a power saw, it will require less starting current. The exact requirement will also vary with the brand or design of the motor.

Self-exciting generators respond to severe overloading differently than utility power. When overloaded, the engine is not able to supply enough power to bring electric motor up to operating speed. The generator responds with high initial starting current, but the engine speed drops sharply. The overload may stall the engine. If allowed to operate at very low speeds, the electric motor starting winding will burn out in a short time. The generator winding may also be damaged.

## PREPARING THE UNIT

### UNPACKING

#### CAUTION: EQUIPMENT DAMAGE

*When you unpack your new generator, be sure to remove all of the information sheets and manual from the carton.*

1. As you receive your unit, it is critical to check it for any damage. If any damage is noted, it is always easiest to refuse the shipment and let WINCO take care of the freight claim. If you sign for the unit, the transfer of the ownership requires that you file the freight claim

2. Before proceeding with the preparations of your new generator

for operation, take a couple of minutes to ensure the unit you have received is the correct model and review the specification pages in this manual to ensure that this unit meets your job requirements.

## UNIT INSTALLATION

Plans for installation should be prepared with proper attention to mechanical and electrical engineering detail to assure a satisfactory system installation. The information in this manual is offered as a guide to finalizing your installation plans. The installation sequence is summarized below.

### PLAN THE INSTALLATION

Generally, two-bearing generators are used on portable equipment. For best service consider the following:

1. All electrical equipment should be protected from excessive moisture. Failure to do so will result in deterioration of the insulation, short circuits, and grounds.
2. The generator should be installed in a sheltered area. If the unit must be left in the open, it should always be protected with a weather cover such as a tarp or large piece of canvas after each use to keep out water and dust.

#### CAUTION: EQUIPMENT DAMAGE

*Always allow the generator and prime mover to cool before covering with a flammable weather covering.*

## MOUNTING

#### CAUTION: EQUIPMENT DAMAGE

*The generator must be mounted with the engine to a common rigid base to prevent stress on the engine and generator shafts and bearings do to vibration displacement. For permanent installations, the engine-generator is usually mounted on a sub-frame which can be shock mounted with neoprene pads on the main frame.*

*Before proceeding with installation, be sure that you have completely read and understood the assembly and installation instructions.*

An engine with adequate horsepower and a close regulated (fixed speed) governor is required for satisfactory operation of this generator. About 1.4 horsepower is required to produce 1,000 Watts of generator output power assuming 100% efficiency of both the engine and the generator. However, due to engine and generator efficiencies of 80 to 90%, the loss of power due to engine driving accessories such as cooling fans, battery charging alternators, etc. friction losses and slippage in the drive pulleys and belts, the general conservative rule of thumb allowing approximately two (2) horsepower for every 1,000 Watts of generator output is much more realistic. For example, the 4,000 Watt generator output will require a 8 horsepower engine for full output, good speed/voltage regulation, and satisfactory load performance. When determining the prime mover/generator pulley ratio to drive the generator at the correct operating speed, bear in mind the power rating of most prime movers (usually an engine) varies with speed. It produces more power at higher speeds, less when slowed.

The prime mover must be fast enough to reach desired horsepower for good generator operation.

The drive belt system must be of adequate size and must be tight enough to power the generator without slippage. Be careful not to over-tighten to the extent that it puts excessive strain on the bearings. Doing so can cause bearing failure and other possible damage to the generator.

Alignment of the generator to the prime mover is important. Misalignment of the pulleys will cause excessive belt and pulley wear and unnecessary stress on the prime mover.

The following table shows the effect of various operating speeds and electrical loads on a typical generator when matched and mounted to an adequate prime mover.

| LOAD VS. OUTPUT |             |                |         |
|-----------------|-------------|----------------|---------|
| Generator Load  | Speed (RPM) | FREQUENCY (Hz) | Voltage |
| None            | 3690        | 61.5           | 129V    |
| Half            | 3600        | 60.0           | 120V    |
| Full            | 3510        | 58.5           | 115V    |

\*Note: Required generator speed must be at 3600 +/- 90 RPM under all load conditions.

Although individual units and models may vary slightly, the normal voltage and frequency of typical 60 cycle engine-driven generators described in this manual are approximately as follows when powered by a typical prime mover (engine) run first with no load applied, then at half capacity as rated on the nameplate.

All engines have a tendency to slow down when a load is applied. The governor on the engine is designed to hold engine speed nearly constant. When the electrical load connected to the generator is increased, the engine is more heavily loaded and as a result, the speed drops slightly. This slight decrease in speed together with the natural "voltage drop" within the generator itself due to load current and heating of the windings, results in a slightly lower voltage than when the generator is running idle.

The normal slight variations on speed also directly affect the frequency of the output current. This frequency variation has no appreciable effect in the operation of most loads (such as motors, lights, and most small appliances).

The speed of the engine is usually adjusted so that the generator produces proper voltage. If the adjustment is made "cold", set the voltage a little higher than normal since it will drop a few Volts as the generator warms up.

NOTE: When operating continuously at full load, the generator shell becomes very warm. It will be uncomfortable to the touch. This is normal for any high performance inherently regulated generator. Output voltage should be checked periodically to ensure proper operation of the generator and appliances.

### CAUTION: EQUIPMENT DAMAGE

*Low voltage may damage any motors or appliances connected to it. Running the generator at excessively high speeds result in high voltage which will also damage electrical devices connected to it. Excessively high speed may also cause damage to the generator armature windings.*

## CONNECTING THE LOADS

### APPLYING THE LOAD

A short warm-up time will permit the engine to work more efficiently when the load is applied and will reduce the wear and extend its life. Receptacles have been provided on the end cover to connect the loads on this generator.

### CAUTION: EQUIPMENT DAMAGE:

*Keep the generator load within the generator and receptacle nameplate ratings. Overloading may cause damage to the generator and/or loads.*

Most electric tools and appliances will have the voltage and amperage requirements on their individual nameplates. When in doubt, consult the manufacturer or a local electrician. The nameplate's amperage rating for electric motors can be misleading. See "Starting Electric Motors" in specification section.

The generator is a limited source of electrical power, therefore pay special attention to the receptacle and generator ratings. The nameplate rating can be obtained through combination of receptacles or a single receptacle as long as the receptacle amperage rating is not exceeded. Both the 120 and 240 Volt output can be utilized at the same time. See specification section for proper load separation. Overloading a specific receptacle or winding group can result in damage to the equipment.

Plug your tools such as drills, saws, blowers, sump pump, and other items to be powered directly into the generator receptacles. Before plugging in all of the tools and cord sets, recheck the rating of the generator. Be sure it can handle the intended load and is compatible with voltage, phase, and current ratings.

'Hard Wiring' this unit directly into a temporary construction site electrical system is NOT A SIMPLE DO-IT-YOURSELF JOB. For your safety, all wiring must be done by a qualified electrician and conform to the National Electric Code and all state and local codes and regulations. Check with local authorities before proceeding.

### WARNING: PERSONAL DANGER

*A fully isolated, double pole throw manual transfer switch must be installed any time a generator is being connected to an existing distribution system.*

### CAUTION: EQUIPMENT DAMAGE

*Failure to properly limit and balance the load applied to the generator will cause the generator to produce low voltage and may damage the generator. It may also cause severe damage to the loads connected to the generator at that time. Improper loading of the generator constitutes abuse and will not be covered by warranty.*

# TROUBLE SHOOTING CHART

| SYMPTOM                 | POSSIBLE CAUSE(S)  | CORRECTIVE ACTION  |
|-------------------------|--|--|
| Low voltage             | <ol style="list-style-type: none"> <li>1. Generator operating at low speed</li> <li>2. Generator overloaded</li> <li>3. Defective stator</li> <li>4. Defective rotor</li> </ol>  | <ol style="list-style-type: none"> <li>1. Generator must be operated at 3600 RPM +/- 90 RPM with a frequency of 60 Hz +/- 2 Hz</li> <li>2. Reduce load to generator nameplate</li> <li>3. Repair stator</li> <li>4. Repair rotor</li> </ol>  |
| Output voltage too high | Engine speed too high  | See engine manual  |
| Generator overheating   | <ol style="list-style-type: none"> <li>1. Generator overloaded</li> <li>2. Poor ventilation</li> </ol>   | <ol style="list-style-type: none"> <li>1. Reduce load</li> <li>2. Clear inlet and outlet air vents of debris. If unit is housed, ensure at least 2 feet clearance on all sides that the inlet and outlet vents are of adequate size</li> </ol>   |
| No output voltage       | <ol style="list-style-type: none"> <li>1. Short in load</li> <li>2. Broken or loose wire</li> <li>3. Defective receptacles</li> <li>4. Defective capacitor</li> <li>5. Defective diodes</li> <li>6. No residual magnetism in generator</li> <li>7. Defective stator</li> <li>8. Defective rotor</li> </ol> | <ol style="list-style-type: none"> <li>1. Disconnect load and find fault in load</li> <li>2. Repair or replace wire</li> <li>3. Replace receptacle(s)</li> <li>4. Replace capacitor</li> <li>5. Replace diode(s)</li> <li>6. Flash the field</li> <li>7. Repair or replace stator</li> <li>8. Repair or replace rotor</li> </ol> |

## WIRING SCHEMATIC

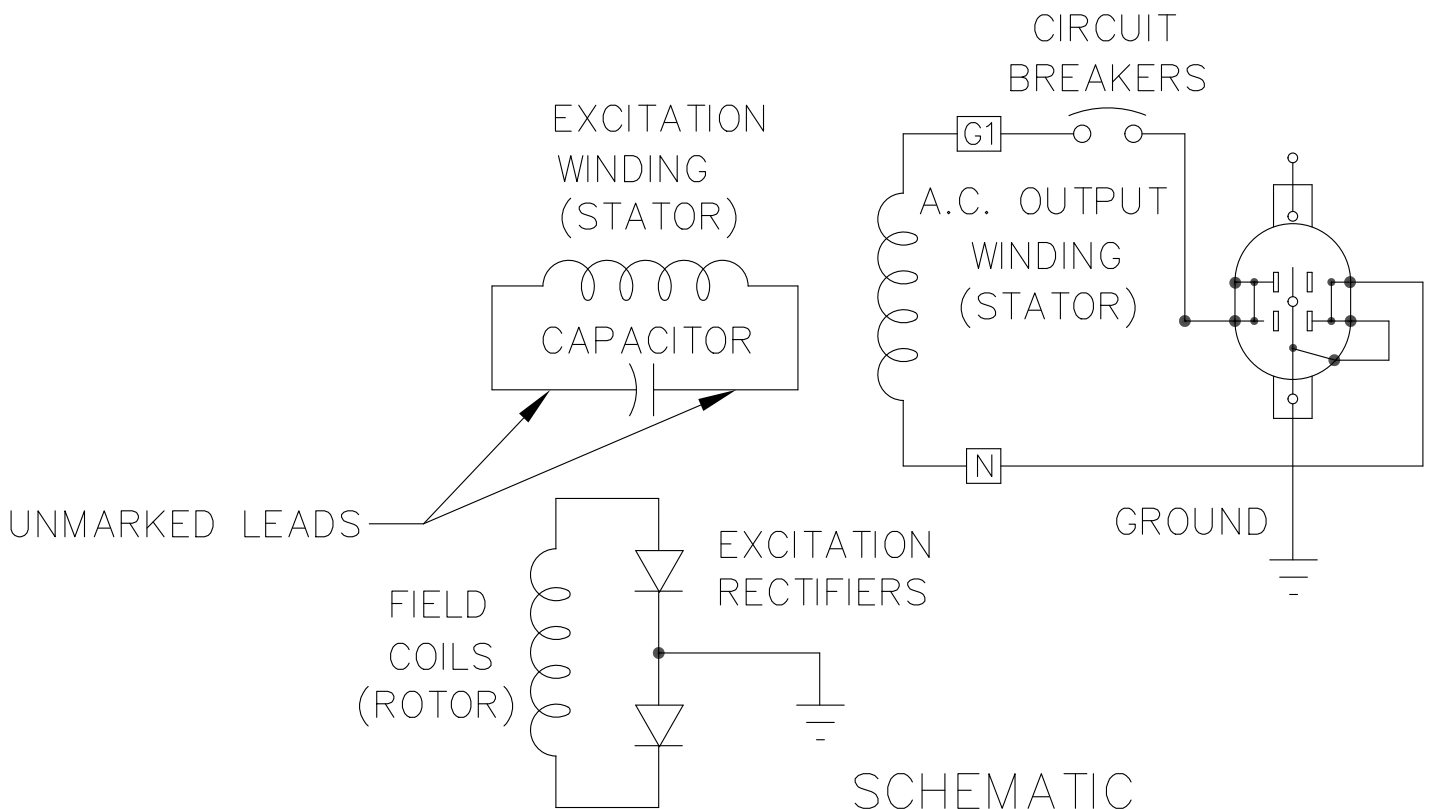

# OUTLINE DRAWING

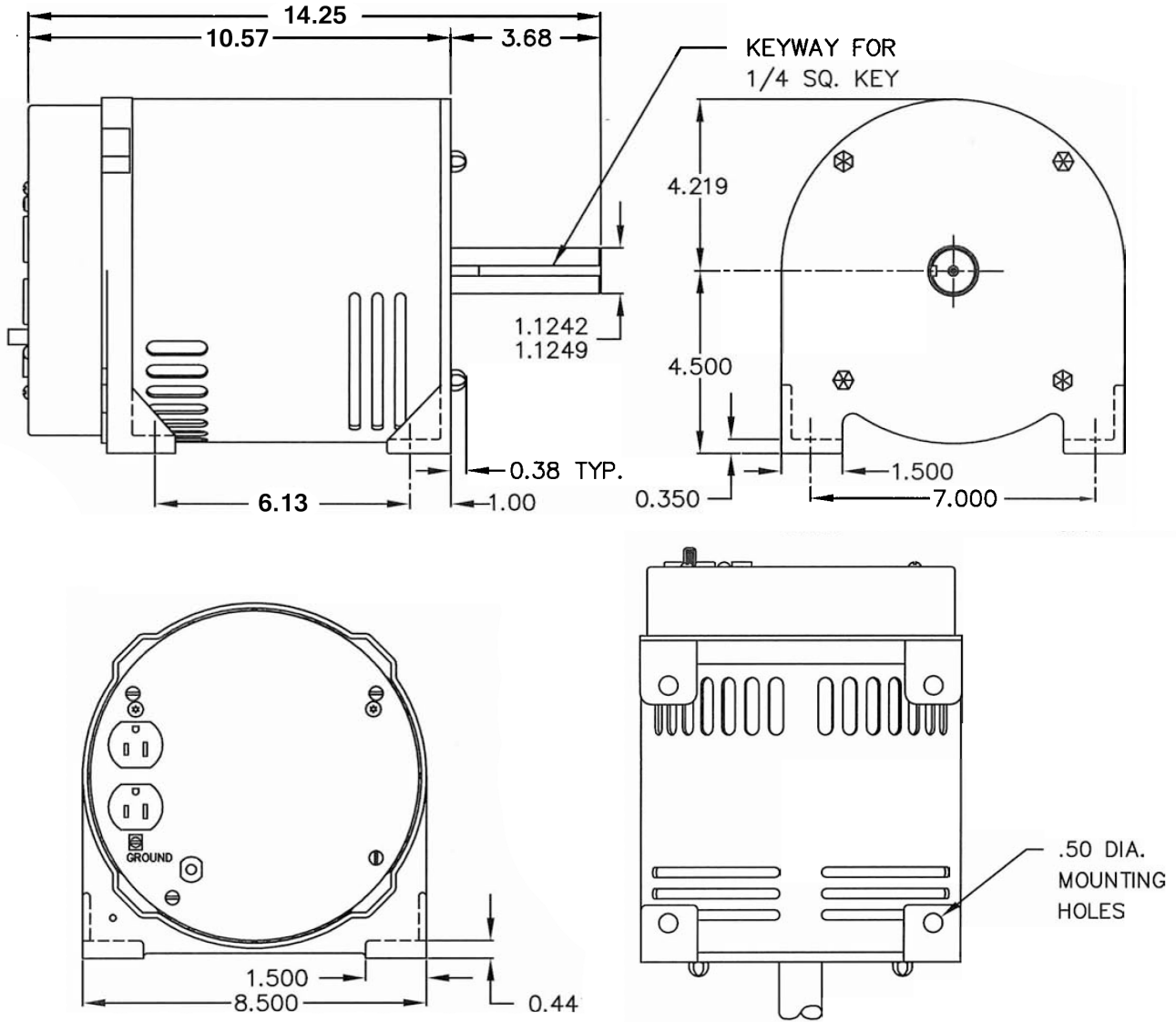



## **12 MONTH LIMITED WARRANTY**

WINCO, Incorporated warrants to the original purchaser for 12 months or 1000 hours which ever occurs first, that goods manufactured or supplied by it will be free from defects in workmanship and material, provided such goods are installed, operated and maintained in accordance with WINCO written instructions.

WINCO's sole liability, and Purchaser's sole remedy for a failure under this warranty, shall be limited to the repair of the product. At WINCO's option, material found to be defective in material or workmanship under normal use and service will be repaired or replaced. For warranty service, return the product within 12 months or 1000 hours which ever occurs first from the date of purchase, transportation charges prepaid, to your nearest WINCO Authorized Service Center or to WINCO, Inc. at Le Center Minnesota.

THERE IS NO OTHER EXPRESS WARRANTY.

To the extent permitted by law, any and all warranties, including those of merchantability and fitness for a particular purpose, are limited to 12 months or 1000 hours which ever occurs first, from date of purchase. In no event is WINCO liable for incidental or consequential damages.

Note: Some states do not allow limitation on the duration of implied warranty and some states do not allow the exclusion or limitation of incidental or consequential damages, so the above limitations may not apply in every instance. This warranty gives you specific legal rights which may vary from state to state.

WINCO reserves the right to change or improve its products without incurring any obligations to make such changes or improvement on products purchased previously.

### **EXCLUSIONS:**

WINCO does not warrant Engines. Engines are covered exclusively by the warranties of their respective manufacturers, see enclosed warranties.

WINCO does not warrant Component Parts that are warranted by their respective manufacturers.

WINCO does not warrant modifications or alterations which were not made by WINCO, Inc.

WINCO does not warrant products which have been subjected to misuse and/or negligence or have been involved in an accident.

This warranty does not include travel time, mileage, or labor for removal or re-installation of WINCO product from its application.