

B-15607-004

CONNECT GENERATOR LEADS TO RECEPTACLE BOX LEADS AS SHOWN ON WIRING DIAGRAM DECAL, ITEM 7

PLACE DECAL AS CLOSE TO END AS POSSIBLE WITH ARROW POINTING TOWARD CIRCUIT BREAKERS

CENTER DECAL ON OPPOSITE SIDE BETWEEN HOLES FOR MOUNTING SCREWS

SEE NOTE 3.

NOTES:

1. INSERT 5 LEADS THROUGH GROMMET, ITEM 20, IN STATOR SHELL BEFORE ASSEMBLING, 2 LEADS ARE TO BE CONNECTED TO LEADS FROM CAPACITORS IN END COVER.
2. SECURE GENERATOR LEADS TO BEARING BRACKET SPOKE WITH CABLE TIE, ITEM 22
3. TORQUE FLANGENUTS, ITEM 23, ON 4 THROUGH BOLTS TO 65 IN.-LBS.
4. FOR OUTLINE DRAWING SEE A-15623-002

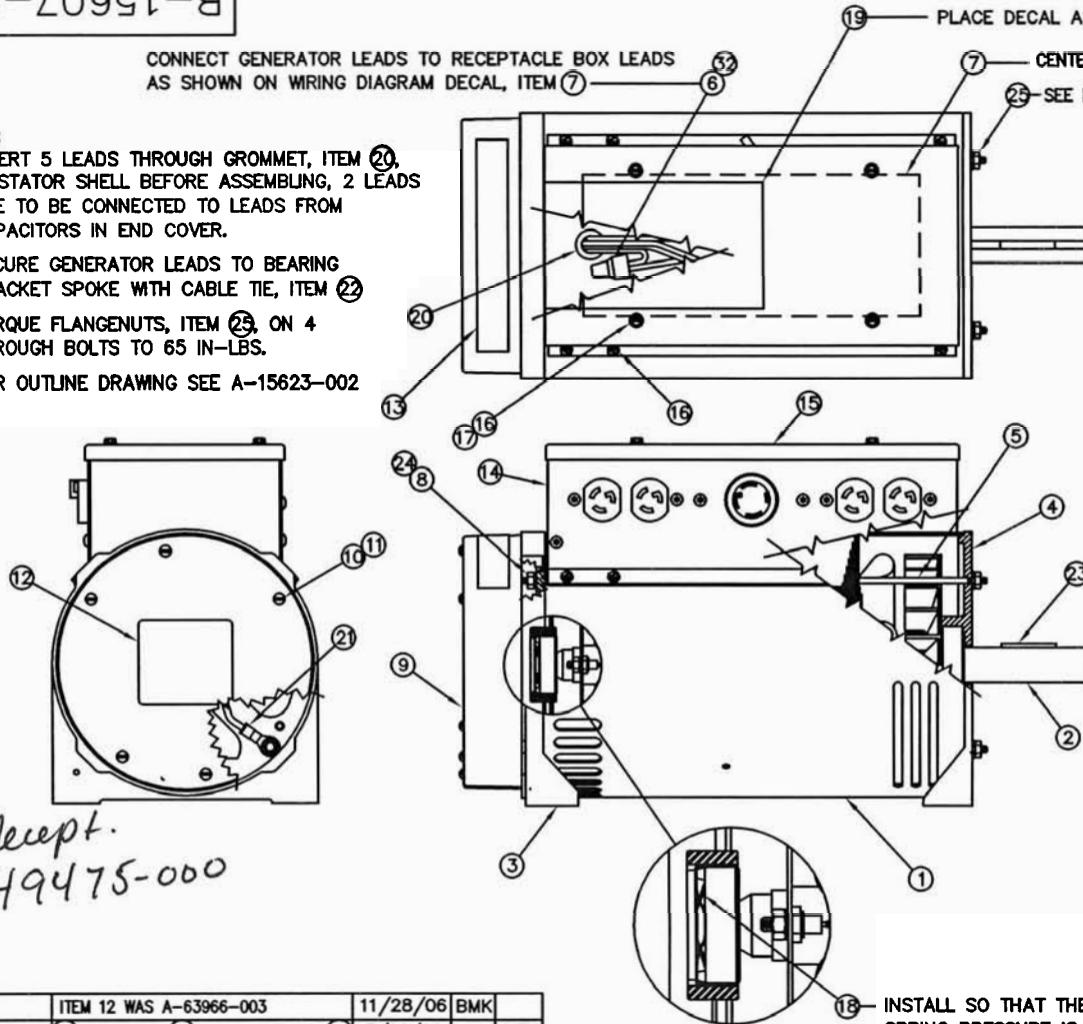

Recept.  
49475-000

INSTALL SO THAT THE WAVE SPRING PRESSURE IS AGAINST THE BEARING OUTER RACE.

33	96936-008	3	TERM., WIRE NUT, 18-10AWG, RED
32	51319-000	1	TERM., SPLICE CAP COPPER
31	B-100054-652	1	BAG
30	B-100054-644	1	INNER PACK LINNER
29	B-100047-686	1	SHIPPING CARTON (NOT SHOWN)
28	24049-000	4	CARRIAGE BOLT FOR SHIPPING (NOT SHOWN)
27	60706-098	1	OPERATORS MANUAL
26	60701-109	1	PARTS LIST
25	A-16248-000	4	1/4-20 HEX FLANGENUT
24	638-000	4	1/4-20 HEXNUT
23	A-44208-000	1	1/4 X 1.75" SQUARE KEY
22	A-49975-011	1	CABLE TIE
21	B-9769-136	1	LEAD WIRE ASSEMBLY (GREEN)
20	A-40832-000	1	GROMMET
19	A-64576-002	1	CIRCUIT BREAKER DECAL
18	A-16174-000	1	WAVE WASHER
17	A-96286-002	4	NYLON WASHER
16	A-21698-001	10	#10-24 X 3/8 SELF TAPPING SCREW
15	B-15620-003	1	RECEPTACLE BOX COVER
14	B-16486-000	1	RECEPTACLE BOX ASSEMBLY
13	B-15209-000	1	DANGER DECAL SET, USE ONLY B-15209-003
12	A-63966-007	1	NAMEPLATE
11	21975-000	4	#10 INTERNAL TOOTH LOCKWASHER
10	A-15013-000	4	#10-32 X 3.50 ROUND HEAD SCREW
9	B-15606-001	1	END COVER ASSEMBLY
8	479-000	4	1/4 SPLIT LOCKWASHER
7	A-64576-003	1	WIRING DIAGRAM DECAL
6	51320-000	1	TERM., NYLON INSULATOR CAP
5	B-15068-002	4	1/4-20 THROUGH BOLT (14.813" LONG)
4	B-15577-002	1	DRIVE END BEARING BRACKET
3	A-15561-001	1	BEARING BRACKET
2	B-15604-000	1	ROTOR ASSEMBLY
1	B-15605-001	1	STATOR ASSEMBLY

ITEM	PART NO	QUAN.	DESCRIPTION
UNLESS OTHERWISE SPECIFIED			
FRACTIONS ±		ANGULAR	MACHINED SURFACE TEXTURE
1. PLACE DEC. ± .1		± 1.5°	ALL DIMENSIONS GIVEN IN INCHES
2. PLACE DEC. ± .03			WORK TO DIMENSIONS
3. PLACE DEC. ± .005			- DO NOT SCALE -
DRAWN BY	DATE	CHKD BY	DATE
IE ID IF	7-13-04		
MATERIAL: X			
FINISH X		TITLE	
ASSY X		COMPLETE UNIT ASSEMBLY	
MODEL TB7200GF1/A		PART NO.	
THIS DRAWING CONTAINS PROPRIETARY INFORMATION BELONGING TO WINCO, UNAUTHORIZED USE IS PROHIBITED.		B-15607-004	



ISSUE	E.C.O. NO.	DESCRIPTION	DATE	BY	APPR.
7		ITEM 12 WAS A-63966-003	11/28/06	BMK	
6	057-06	6 WAS QTY 4, (32) WAS QTY 4, ADD (33)	3/14/06	PJT	MTH
5	076-05	6 WAS 96936-008, ADDED (32)	6/22/05	AJG	MTH
4	024-05	(16) WAS 53644	3/4/05	MTH	MTH
3	158-04	ADDED (31) CHANGED PLACEMENT OF (7)	12/20/04	MTH	MTH
2	140-04	ADDED (26) & (27)			
1		(5) WAS PN 15068-010	10/12/04	MTH	EDF
		ORIGINAL	---	---	---

REVISION RECORD

# TB 7200 GFI/A

