

WARNING LIGHT CLUSTER (IF SUPPLIED)

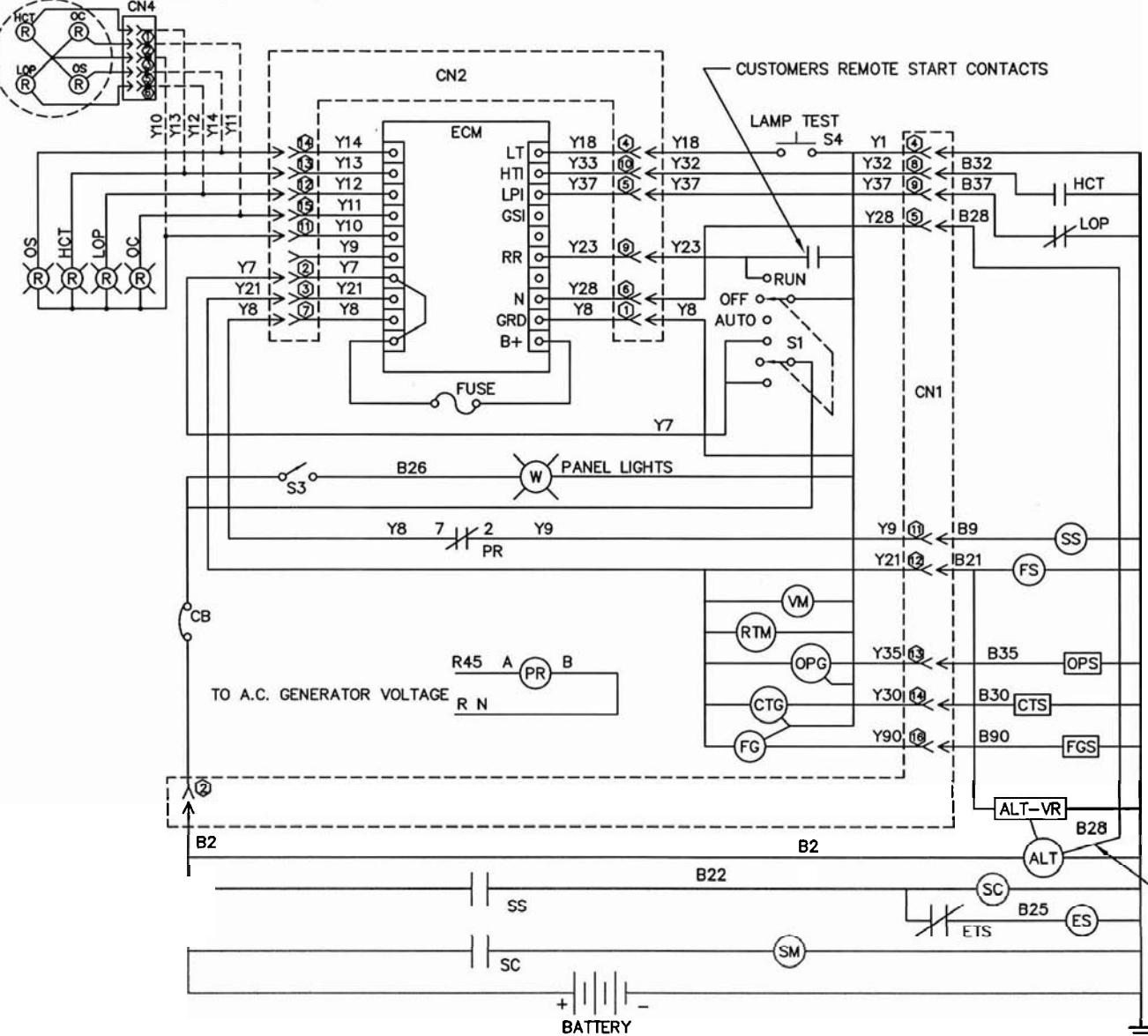

LEGEND

- ALT ALTERNATOR
- ALT-VR ALTERNATOR VOLTAGE REGULATOR  
MAY BE INTEGRAL WITH ALTERNATOR
- AUTO AUTOMATIC POSITION OF SWITCH S1
- CB CIRCUIT BREAKER
- CN1 & CN2 WIRING HARNESS CONNECTORS
- CTG COOLANT TEMPERATURE GAUGE
- CTS COOLANT TEMPERATURE SENDER
- ECM ENGINE CONTROL MODULE
- ETS ETHER TEMPERATURE LOCKOUT SWITCH
- ES ETHER SOLENOID VALVE
- FG FUEL GAUGE
- FGS FUEL GAUGE SENDER
- FS FUEL RACK SOLENOID
- GND GROUND (CHASSIS OR FRAME)
- HCT HIGH COOLANT TEMPERATURE SWITCH
- LOP LOW OIL PRESSURE SWITCH
- OC OVERCRANKING INDICATOR LAMP
- OPG OIL PRESSURE GAUGE
- OPS OIL PRESSURE SENDER
- OS OVERSPEED INDICATOR LAMP
- PR START SIGNAL DISCONNECT RELAY
- RTM RUNNING TIME METER
- S1 ENGINE START MODE SWITCH
- S3 PANEL ILLUMINATION LIGHT SWITCH
- S4 ENGINE SHUTDOWN INDICATOR LAMP TEST SWITCH
- SC ENGINE STARTER MOTOR SOLENOID
- SM ENGINE STARTER MOTOR
- SS STARTER SOLENOID
- VM D.C. VOLTMETER

"R" TERMINAL

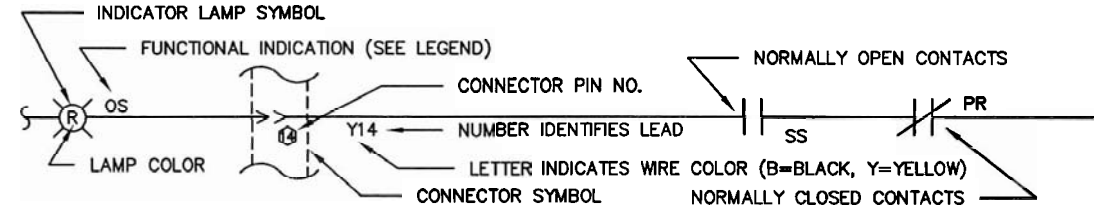

UNLESS OTHERWISE SPECIFIED		MACHINED SURFACE TEXTURE		ALL DIMENSIONS GIVEN IN INCHES			
FRACTIONS ±	---	ANGULAR	±	WORK TO DIMENSIONS			
1. PLACE DEC. ±	---			- DO NOT SCALE -			
2. PLACE DEC. ±	---						
3. PLACE DEC. ±	---						
DRAWN BY	DATE	CHKD BY	DATE	APP'D BY	DATE	SCALE	
E.D.F.	4-24-91					1"=1"	
DRAWING CONTAINS PROPRIETARY INFORMATION BELONGING TO WINCO. UNAUTHORIZED USE IS PROHIBITED.		FINISH		TITLE			
		C-98854/98855		D.C. SCHEMATIC			
		MD45/E & MD65/E		PART NO.		C-98937	
		WINCO INCORPORATED					