

C-93044

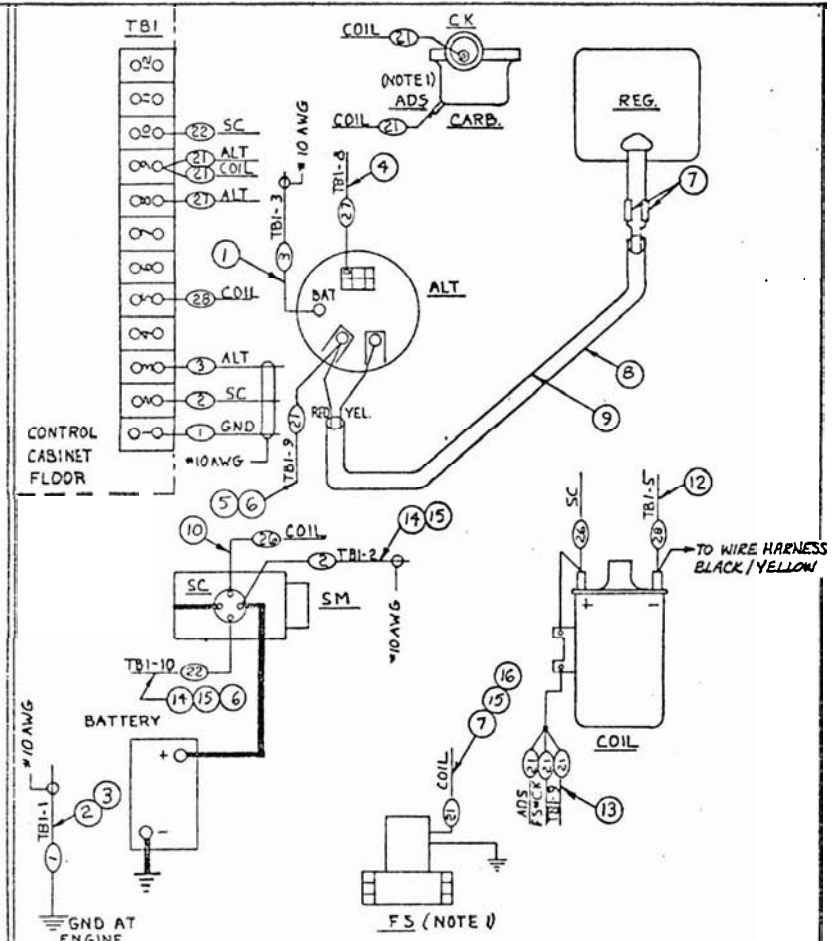
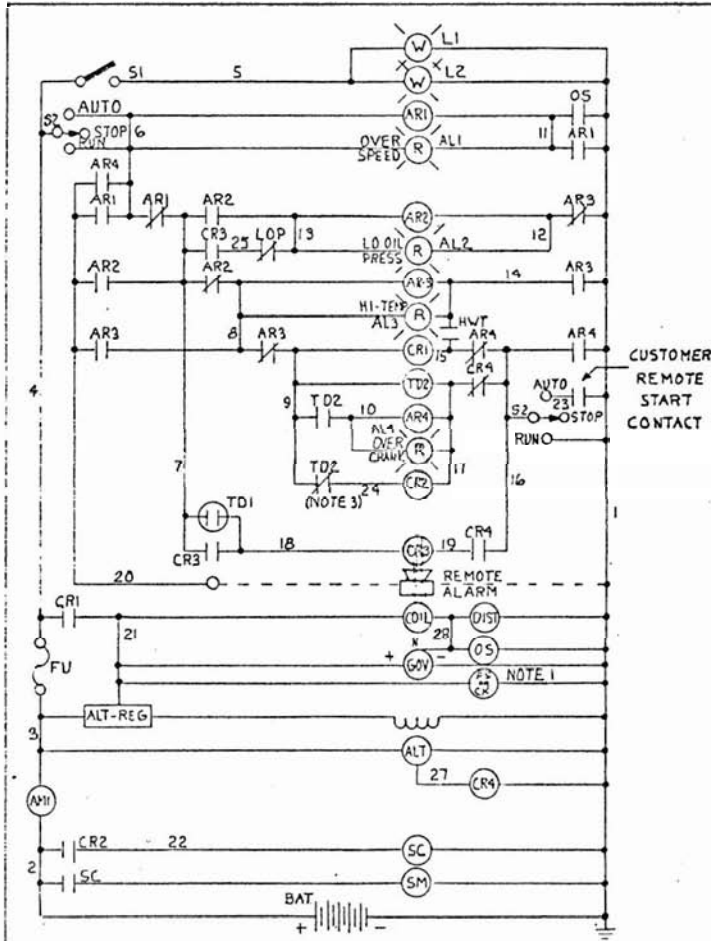

SYM	DESCRIPTION	SYM	DESCRIPTION
ADS	ANTI-DIESEL SOLENOID	HWT	HI WATER TEMP
AL	ALARM LIGHT	L	LIGHT
ALT	ALTERNATOR	LOP	LO-OIL PRESSURE
AM	AMMETER	OS	OVER SPEED
AR	ALARM RELAY	S	SWITCH
CK	CHOKE	SC	STARTER CONTACTOR
CR	CONTROL RELAY	SM	STARTER MOTOR
FS	FUEL SOLENOID	TB	TERMINAL BLOCK
FU	FUSE	TD	TIME DELAY RELAY

NOTES:

1. ADS (ANTI-DIESEL SOLENOID) AND CK (CHOKE) ARE USED ONLY ON GASOLINE MODELS FS (FUEL SOLENOID) IS USED ONLY ON LPG OR NAT. GAS MODELS.
2. EXCEPT AS NOTED ALL WIRES TO BE #16 GA.
3. TD2 CRANKING CONTACT IS N.C. FOR CRANKING LIMITER STANDARD AND N.O. FOR CYCLE CRANKING (OPTIONAL CONTROLS)
4. SEE C-92992, GOVERNOR ASS'Y, FOR GOVERNOR INTER-CONNECTION

ITEM	PART NO.	QUAN.	PLANE	DETAILS	ITEM	PART NO.	QUAN.	PLANE
16	B-10468-18	1	LEAD WIRE					
15	4158	4	LUG					
14	B-10468-19	2	LEAD WIRE					
13	B-52133-59	1	LEAD WIRE ASS'Y	BLACK				
12	B-52130-102	1	LEAD WIRE ASS'Y	BLACK				
11								
10	B-52130-78	1	LEAD WIRE ASS'Y	BLACK				
9	A-41255-8	1	LEAD WIRE	YELLOW				
8	A-41190-10	1	LEAD WIRE	RED				
7	58077	3	LUG					
6	7777	2	LUG					
5	B-10468-68	1	LEAD WIRE					
4	B-52135-12	1	LEAD WIRE ASSEMBLY	GREEN				
3	21319	1	LUG					
2	B-52123-36	1	LEAD WIRE ASS'Y	WHT				
1	B-1719-99	1	LEAD WIRE ASS'Y	BLK				

DRAWN BY		DATE		CHKD BY		DATE		APPR'D BY		SCALE	
D.M.W.		3-19-81		RN		3-21-81				—	
MATERIAL											
FINISH											
ART 092844											
MODEL 15CS											
D.C. SCHEMATIC / ENGINE CONNECTION DIAGRAM											
REVISED B-52130-139 SCHEMATIC REVISED 3-14-81 JCM											
ORIGINAL											
DATE BY AUTH.											
3/14/81											
DESIGNED BY DYNMA TECHNOLOGY, INC. LeCenter, MN 55067											
C-93044											