

# INSTRUCTIONS FOR ASSEMBLING OCTOPUS PLUG AND LEAD WIRES

For: Plug Assemblies

- 91357 (3 pin)  
91355 (4 pin)

125 Amp

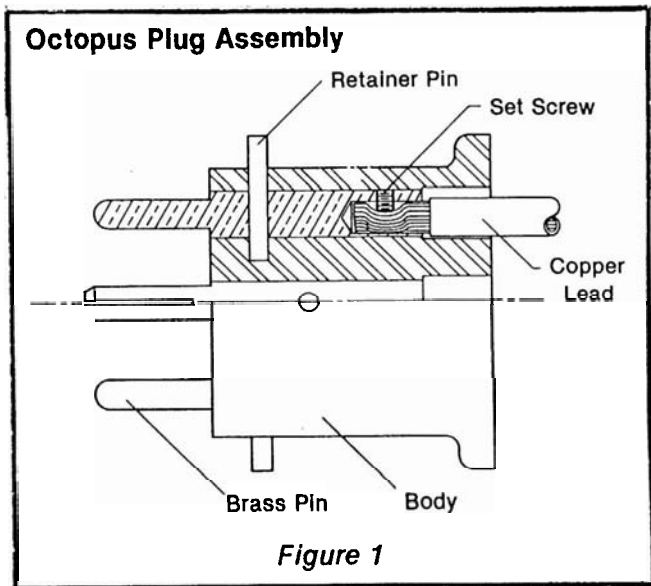

NOTE: IT IS SUGGESTED THAT A COMPETENT ELECTRICIAN PERFORM THE FOLLOWING STEPS:

1. Cut four gauge copper lead wire to the length that will reach between the generator and the transfer switch. Suggested type is:
  - a) Four gauge flexible motor wire, neoprene, or silicone insulated, 133 strand x 25 gauge, 600 volt.
2. Remove 7/8" of insulation from one end of each lead wire.
3. Pull the retainer pin from the plug body and remove the brass pin (Note - the retainer pins are to be used for assembly - DO NOT LOSE).

4. Loosen the set screw in the brass pin. Insert the stripped end of the lead wire full depth in the brass pin opening. Tighten set screw securely.

**CAUTION:** A LOOSE CONNECTION WILL CAUSE ARCING AND HEAT DAMAGE.

5. Insert the brass pin in the body and line up retainer pin holes.
6. Install the retainer pin; tap retainer pin firmly into place. Pin will protrude approximately 3/8" when fully seated.
7. Repeat steps 3 and 6 for each brass pin (3 pins on the single phase units, and 4 on the three phase units).
8. The neutral lead is to be connected to the large diameter pin "N" on the plug and is to be identified and color coded in conformance with applicable local codes.
9. Strip the other end of the lead wires and connect them to the transfer switch. Be sure to connect the generator neutral lead to the neutral or ground terminal in the transfer switch.

**NOTE:** ON THREE PHASE UNITS ONLY -

Three phase motor rotation can be reversed by interchanging the leads from the "A" pin and "C" pin at the transfer switch.