

INSTALLATION INSTRUCTIONS FOR 2-WIRE AUTO START CONTROL

The following instructions are provide to convert the PSS15B4W from a special 4-wire start system to a standard 2-Wire Auto Start system.

Items required:

WINCO Conversion Kit # 16448-003 Auto Start
T25 Torx Screwdriver
7/16" End Wrench or Socket & Driver
Side Cutter

PROCEDURE

1. Move the toggle switch to the off and stop position.

2. Remove the generator end panel opposite the air discharge.

3. Remove the battery negative cable if the battery is installed.

4. Remove the cover over the customer connection box.

5. Remove both black wiring cables plugged in the current 4-wire engine control. These connectors have threaded retaining collars. Turn the collars counterclockwise to release and pull to remove the connectors.

6. Remove the two sheet metal screws (T-25 Screws) holding the 4-wire engine control in place. Remove the engine control and set aside.

7. Reuse the two sheet metal screws to install the new 2-wire engine control. Be sure the toggle switch is in the **OFF** (center) position.

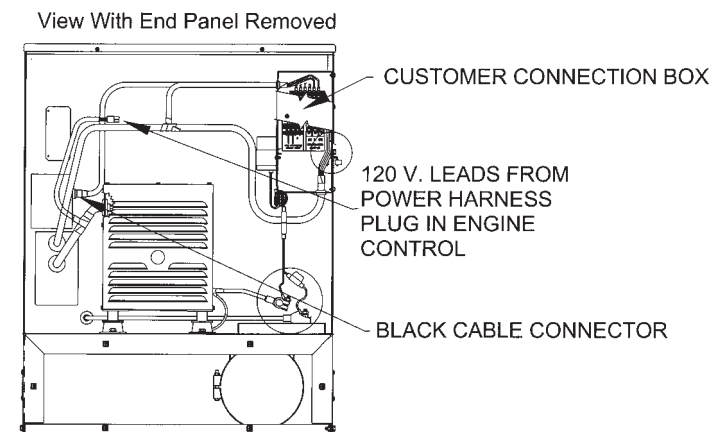
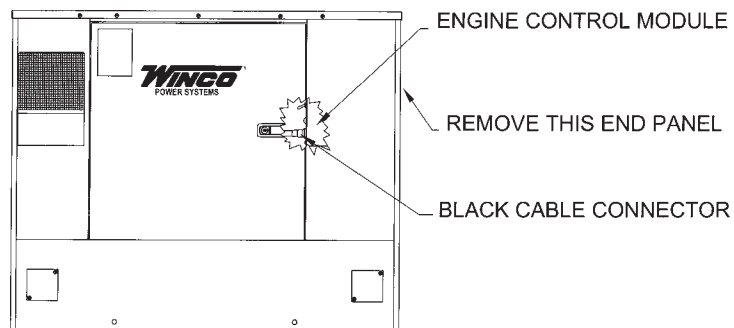

8. Reconnect the two black connectors; be sure to turn the locking rings on tight. But do not over tighten or you will break the locking rings.
9. Locate the small white 2 wire connector on the back end of the unit tie wrapped to the AC harness running from the generator to the customer control box. This connector must be plugged into the mating connector on the side of the new engine control. (This is a 120-Volt signal for the stop crank relay inside the engine control. If it is not connected the starter will never disengage and the unit will go into fault.)
10. Inside the DC portion of the customer connection box locate wire #22. Using the wire tag #23 provided in the kit relabel wire #22 to #23.
11. Cover the 4-wire decal # 64576-011 on the backside of the customer connection box cover with the 2-wire decal 64576-015. This is the new wiring instruction for connecting the unit to an Automatic Transfer Switch. See New operators manual for addition wiring details.
12. Reinstall the cover on the connection box.
13. Locate the engine control description label just to the left of the engine control. A new label has been provided with this kit, paste it over the existing label.
14. Remove the operators manual part number 60706-185 for model **PSS15B4W** from the literature package and replace it with operators manual part number 60706-186 for Model **PSS15B2W**. This replacement manual contain the proper information for installation and operation of a 2-wire auto start system. The customer must have this manual in order to start and operate the unit after the installation of the new engine control.
15. Reconnect the Negative battery cable if the battery is installed. Be sure the toggle switch on the engine control is in the **OFF** position.
16. Replace the end panel.
17. Install the label "THIS UNIT HAS BEEN CONVERTED TO USE A TWO-WIRE START ENGINE CONTROL" just below the engine control inside the enclosure.
18. Using the new operators manual, 60706-186 this unit is now ready to be installed as a standard 2-wire start system. This Generator set will now work with any transfer switch that provides a 'dry' relay closure for a start/run signal

If you encounter any problems or need assistance, feel free to contact the WINCO Service Department at 507-357-6831

WINCO INC[®]
A Division of **DT** Dyna Technology Inc
225 SOUTH CORDOVA AVE
LE CENTER MN 56057
Phone: 507-357-6831
www.wincogen.com