

### TECHNICAL BULLETIN

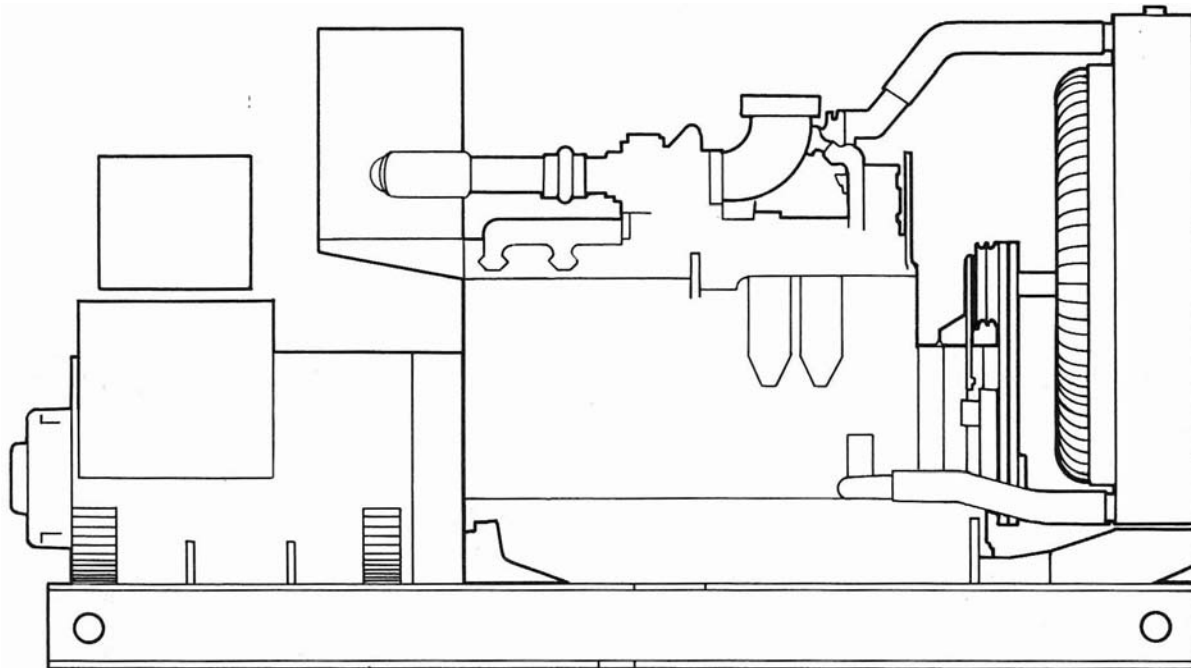

Figure A

#### **CAUTION**

All electrical/mechanical equipment should be operated at regular intervals to insure reliable performance lubrication and to dry electrical winding. WINCO recommends running generator sets once a week at no load for 15 minutes (an optional automatic exercising clock is available for remote start units), and once a month under full connected load for a similar interval.

## Index

<i>Installation Instructions</i> .....	3-6
<i>Local, State or NFPA Regulations</i> .....	7
<i>LP/NG Fuel Adjustments</i> .....	7-9
<i>Maintenance Record</i> .....	10



## Limited Warranty

Winco Division of Dyna Technology, Inc., warrants that for one year from date of shipment it will repair or replace for the original user the whole or any part of the product found upon examination by Winco at its factory at 225 South Cordova Street, LeCenter, Minnesota, or by any Factory-Authorized Service Station to be defective in material or workmanship under normal use and service.

For warranty service, please return the product within one year from date of shipment, transportation charges prepaid, to the Winco factory or to your nearest Factory-Authorized Service Station as listed in the 'Yellow Pages' under Generator-Electric.

**THERE IS NO OTHER EXPRESS WARRANTY. TO THE EXTENT PERMITTED BY LAW, ANY AND ALL IMPLIED WARRANTIES, INCLUDING THOSE OF MERCHANTABILITY AND FITNESS FOR A PARTICULAR PURPOSE, ARE LIMITED TO ONE YEAR FROM DATE OF SHIPMENT, AND LIABILITY FOR INCIDENTAL OR CONSEQUENTIAL DAMAGES OR EXPENSES IS EXCLUDED.** Some states do not allow limitations on the duration of an implied warranty, and some states do not allow the exclusion or limitation of incidental or consequential damages, so the above limitation or exclusion may not apply to you. This warranty gives you specific legal rights; you may have other rights which vary from state to state.

Winco does not warrant engines, batteries, or certain other component parts of the product since such items are warranted by their manufacturers.

Winco does not warrant alterations or repairs which were made by someone other than the Winco factory or a Factory-Authorized Service Station and which affect the stability or reliability of the product.

Winco does not warrant products which have been exposed to misuse and/or negligence or have been involved in an accident.

Winco reserves the right to change or improve its products without incurring any obligations to make such changes or improvements on products purchased previously.

# Installation Instructions

## Safety Information

**CAUTION:** Possible damage to equipment

**CAUTION** Caution notes indicate any condition or practice, which if not strictly observed or remedied, could result in damage or destruction of the equipment.

**WARNING:** Personal danger



Warning notes indicate any condition or practice, which if not strictly observed, could result in personal injury or possible loss of life.

The size of the automatic emergency power package or generator set, associated control panel, and switch/gear has to be established, and plans for installation should be prepared. Proper attention to mechanical and electrical engineering details assure a satisfactory power system installation. The information in this bulletin is offered as a guide to finalizing your installation plans.

- A. Space required and location
- B. Floor loading
- C. Vibration transmitted to building and equipment
- D. Ventilation of room, engine and generator
- E. Engine exhaust and piping
- F. Size and location of fuel system
- G. Electrical connections
- H. Local, state and federal codes, and insurance regulations

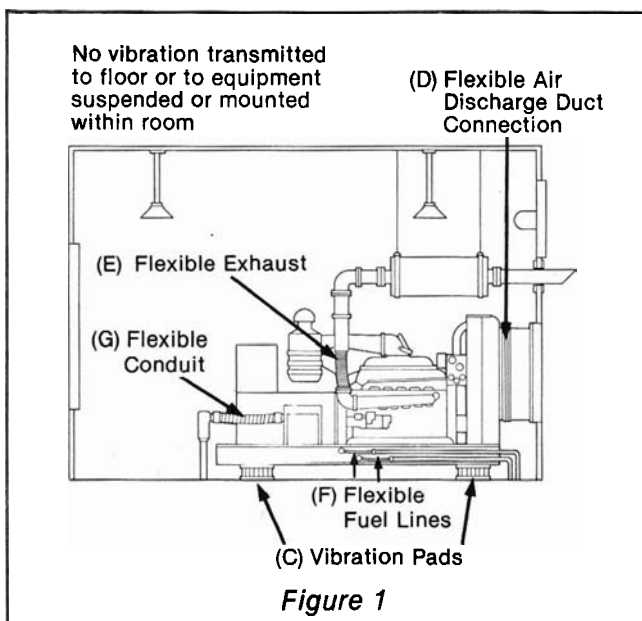

## A. Space Required and Location

The space required should allow for ample working room around and in back of engine generator set. A general rule to follow is three (3) feet clearance. This allows service men to repair and remove engine or generator parts in the event service is needed. The generator should be placed near an outside wall. Location of engine generator should be as close to electrical service and fuel source as possible. This will reduce the cost of electrical and fuel runs. The unit should be protected from adverse weather conditions.

## B. Floor Loading

Floor type and loading should be taken into consideration when installing an engine generator set. The engine generator should be anchored to a 4" to 6" concrete pad. The WINCO engine generator set is shock mounted to the skid on gas/gasoline models. This allows the skid to be directly mounted to the pad. On the larger and heavier diesel powered units, the skid vibration will have to be isolated from the pad with suitable shock mounts. Vibration pads are provided standard.

## C. Vibration Transmitted to Building and Equipment

The engine generator is a rotating piece of equipment that causes vibration to be transmitted to any surface it comes in contact with. When installing

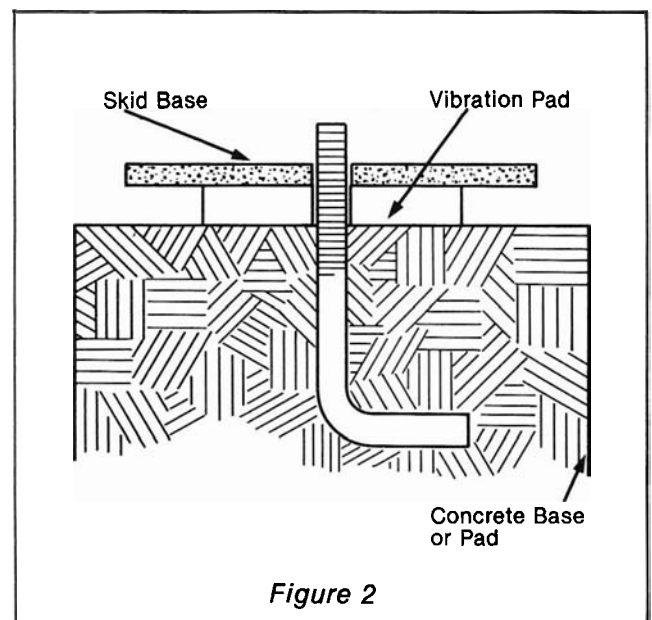

an engine generator this must be taken under consideration. Most buildings or enclosures cannot withstand excessive vibration. When installing the skid, if unit is not already shock mounted to the skid, vibration pads should be installed between the skid and pad. See Figure 2.

When installing the holds down nuts, a wedge or channel washer should be used. Do not over-tighten, as this will dampen the effect of the vibration pad. See Figure 3.

Once the unit is bolted down, you should grab a solid piece of the engine and shake it. The unit

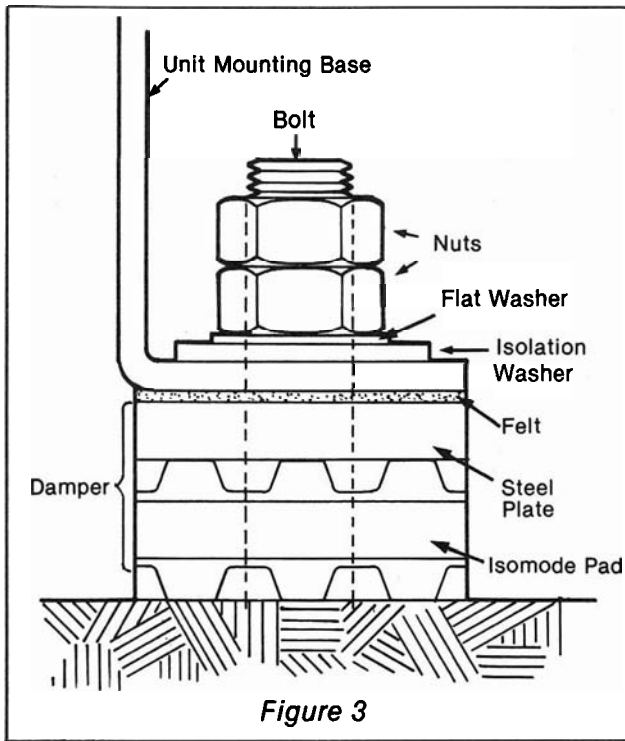

Figure 3

should have some movement, about 1/2" minimum in each direction. If the unit doesn't have the necessary deflection, back off the lock nuts.

**D. Ventilation of Room, Engine and Generator**

The engine is an internal combustion device which can be air-cooled or water-cooled. On water-cooled sets, you will need to provide inlet and outlet air, for proper engine performance. The

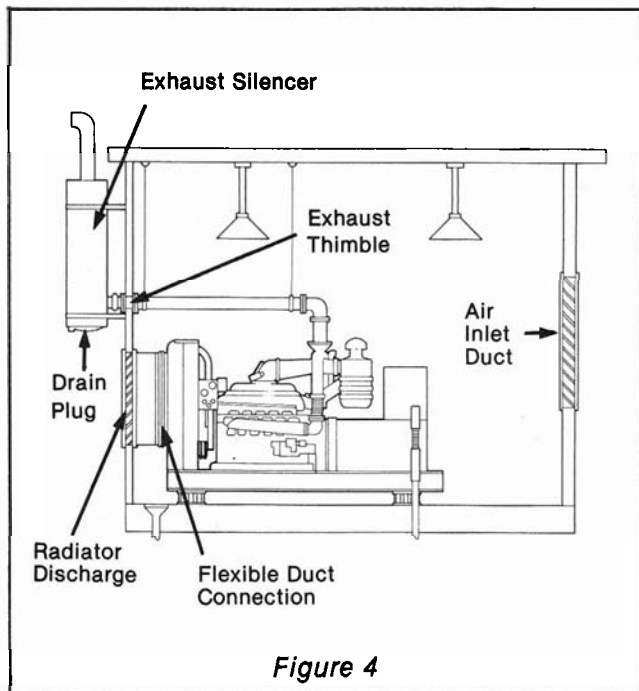

Figure 4

water-cooled units have a radiator with a pusher-type fan that is skid mounted. To discharge hot air out of the building, it will be necessary to duct it out. The hot air discharge duct should be made of

sheet metal with a flexible duct connection installed. See Figure 4.

The flexible section is installed to allow vibration and flex movement of the engine. This flexible section should be capable of expanding a minimum of 2". The air discharge duct should be air tight to the outside. The discharge end of the duct should have a screen or some other device to keep rodents out. Louvers can be used to keep building secure and minimize winter drafts. Movable or fixed type louvers can be used with satisfactory results.

**NOTE:** Local weather conditions should be considered when choosing the type of louver.

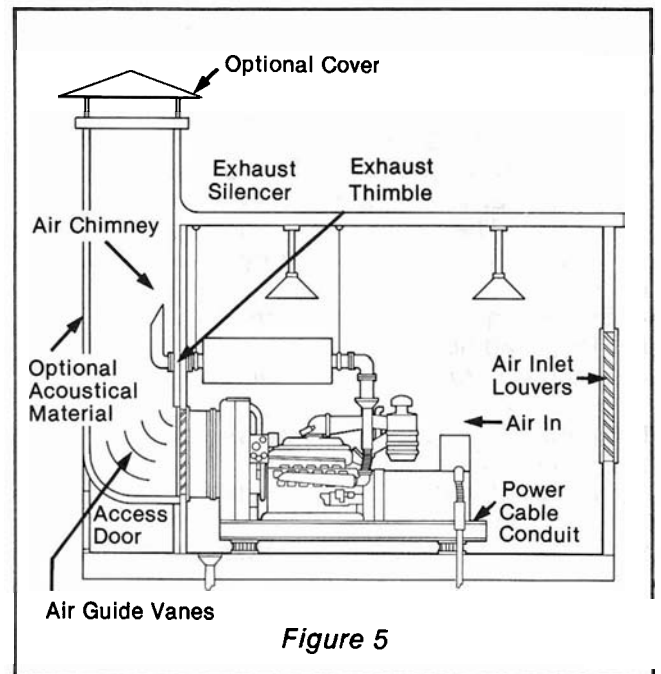
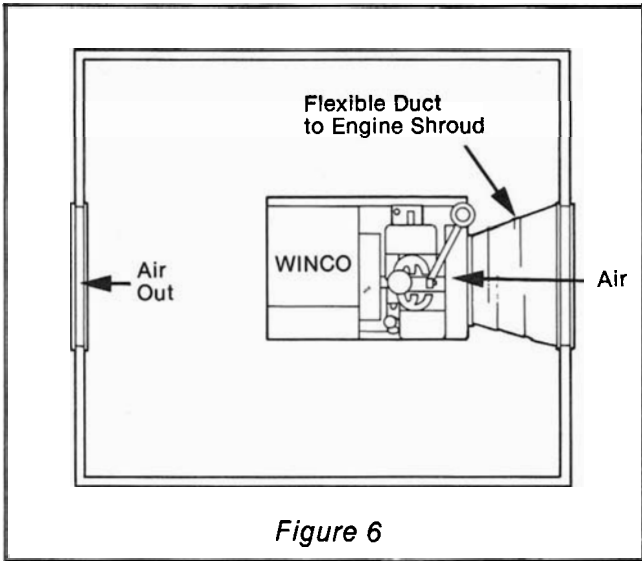

Figure 5

Cool air inlet opening should be 1 1/2 times as large as the radiator air out duct. The extra inlet area is needed to minimize restriction and to provide combustion air for the engine. This inlet should ideally be opposite the hot air exhaust, sweeping a flow of air across the entire machine. See Figure 5.

Thermostatically controlled vents in the roof or high wall can be added to help cool the upper area. These vents would be optional.

On air-cooled units, the ventilation should also be a sweeping flow. When an engine-generator is installed in a building, it should have an air inlet opening 1 1/2 times the area of the engine inlet screen, and an air discharge opening at least as large as the engine inlet screen. The hot air discharge should be above the cool air inlet, as the hotter air will rise. See Figure 6.



**Engine exhaust gases are deadly and must be vented to the outside of any building.**

**E. Engine Exhaust and Piping**

The exhaust piping must be as short as possible. On runs over 25 feet, consult the factory. The exhaust run should be limited to three 90° elbows or six 45° elbows. The pipe size should remain the same size or larger than the exhaust manifold of the engine. No reducers are permitted in an exhaust run, since it creates excessive back

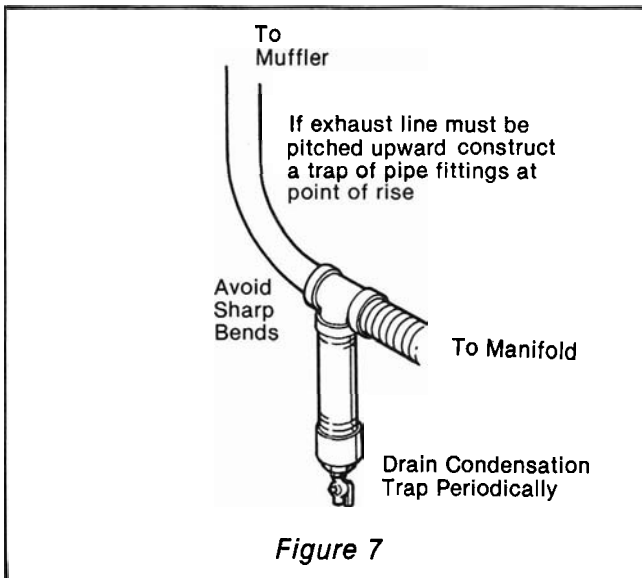

pressure which overheats the engine. A long condensation trap on the muffler should be installed. *See Figure 7.*

The muffler preferably will be installed outside to keep the room cooler. If the muffler must be in-

stalled in the room it should be insulated to reduce heat radiation and guarded to protect personnel. Adequate ventilation must be provided.

**Fire Hazard, Consult NFPA**

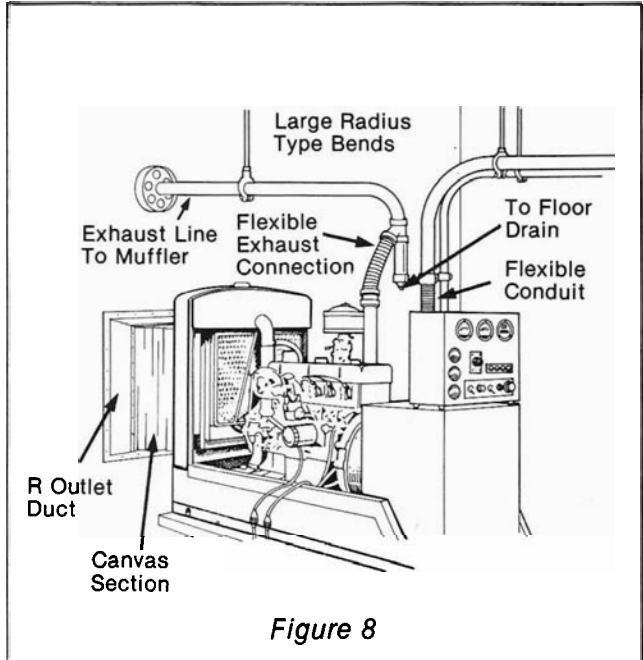

Flexible pipe section: a flexible exhaust section must be installed in the exhaust run, as near to the engine as practical. *See Figure 8.*

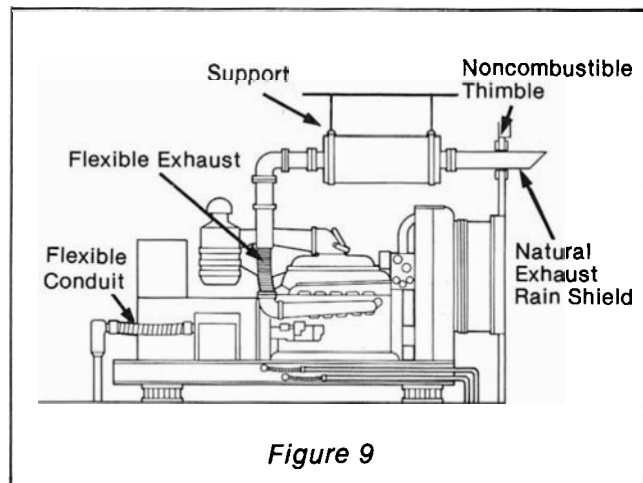

The flex exhaust section is not intended to be used as an elbow or exhaust hanger. The exhaust run must be supported with a noncombustible strap and thimble to take the weight off the engine exhaust manifold. Consult NFPA for recommended practices. *See Figure 9.*

If the exhaust pipe passes through the building wall, a noncombustible exhaust thimble must be used to prevent fires. Exhaust temperatures can exceed 900° F. The exhaust thimble prevents excessive heating of the building wall or roof. Consult NFPA for construction and installation details.

### F. Size and Location of Fuel System

The fuel supply should be as close to the engine generator as possible. This will reduce the installation cost of the fuel runs. See Figure 10.

Diesel fuel: The tank size is dependent on the length of the power outage. A minimum recom-

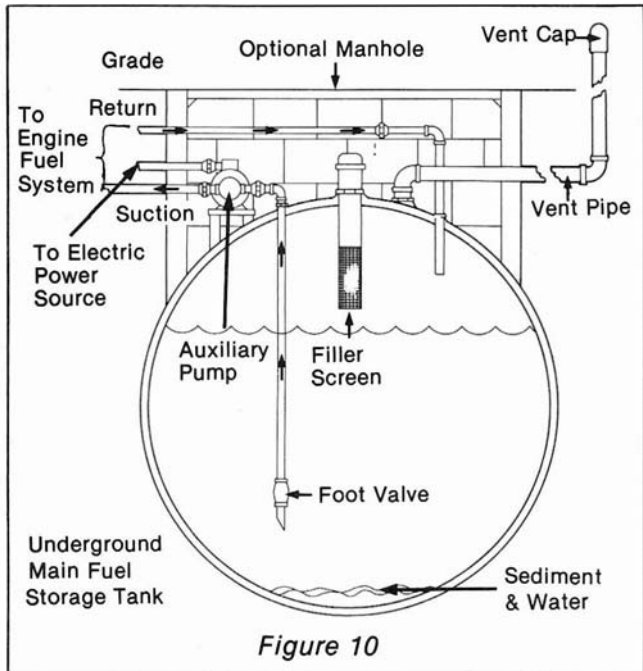

Figure 10

mended fuel supply would be for 24 hours. *Example:* If the engine generator fuel consumption is 5.6 gallons at full rated load, 5.6 gallons × 24 hours = 134.5 gallons, and a 150 gallon supply of diesel fuel would be sufficient. Tank installation can be above or below ground. All tank installations must comply with NFPA, local, state, and county codes. If the tank is less than 25 feet away from the engine-generator, the supply line should be 1/2" and the return line 3/4". The use of a day tank or auxiliary tank will be determined by the lift on the fuel injector pump. If a day tank is used, it should be capable of holding one hour of fuel at full load. *Example:* If the fuel consumption is 8.6 gallons per hour, the day tank size should be 10 gallons.

Above ground type fuel tanks are gravity fed and should be installed in compliance with NFPA, local, state, and county codes. Some engine injector pumps cannot withstand the positive head pressure created by an above ground tank. Consult the factory for recommendations.

Gaseous Fuel Operation: Includes LP vapor withdrawal and natural gas operation. The important factor to be considered is a constant incom-

ing line pressure of 4 oz. to 6 oz. (7" to 11" W.C.). If the pressure is in the 4-6 oz. range, a primary regulator is not required. See Table 1 for recommended line size.

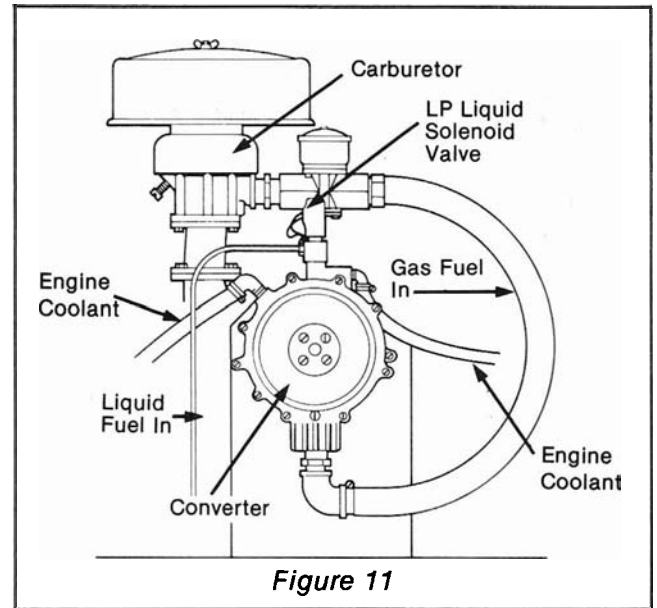
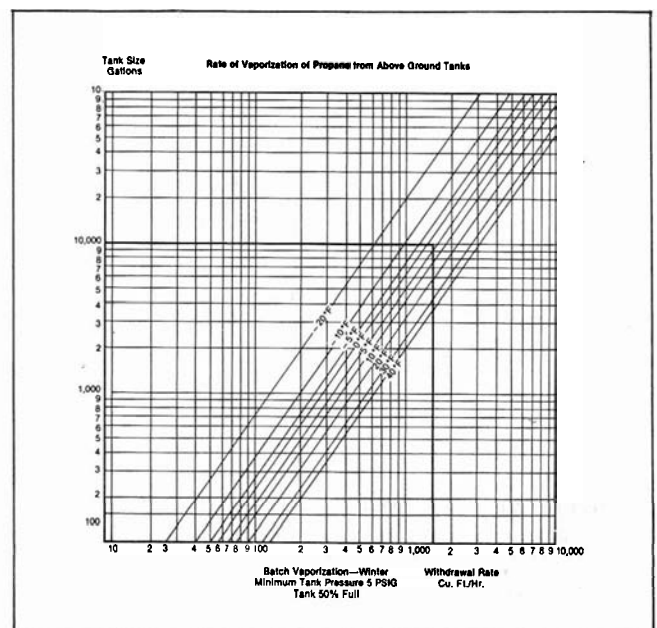

Figure 11

See Table 2 for LP vapor tank size. Note the tank must be larger to supply adequate fuel @ a lower temperature. See Table 4. Table 3 provides fuel consumption data by KW.

LP liquid withdrawal is recommended for most water-cooled engine-generator sets of over 30 KW rating. LP liquid withdrawal fuel should be used to minimize the size of the fuel tank needed in an LP system. By using a converter, the fuel can be drawn out of the tank as a liquid and converted to vapor by using hot water taken from the engine cooling system. See Figure 11. We strongly recommend the engine be equipped with a tank or block heater. This heater is available as an option or can be installed in the field by qualified personnel.



## G. Electrical Connections

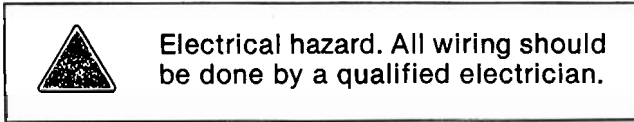

The electrical connections on the unit must be in accordance with the National Electrical Code. All electrical runs should have a flexible metal conduit installed between the AC power run and the unit control box. See *Figure 12*. Consult appropriate control instruction manual for specific details.

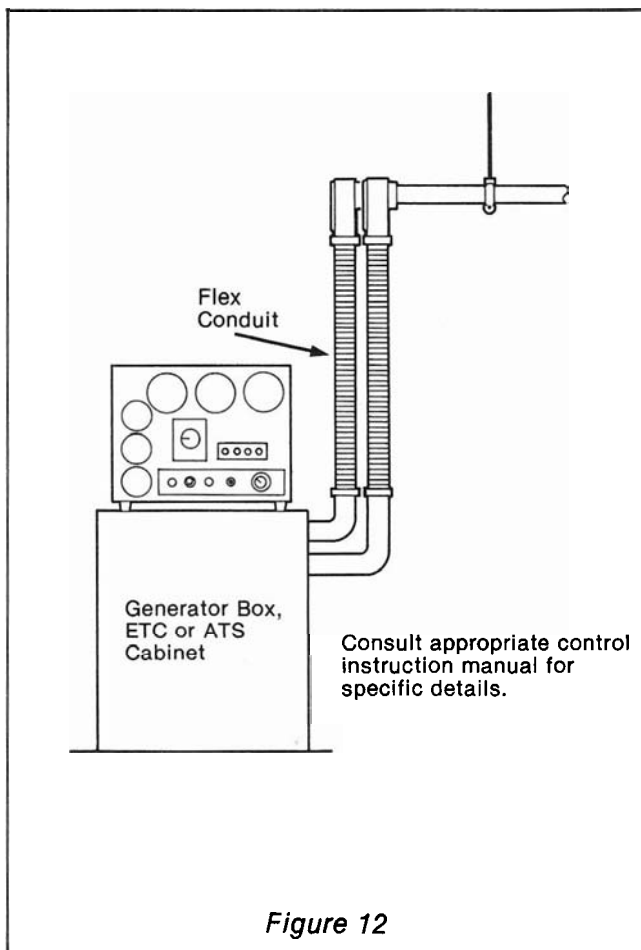
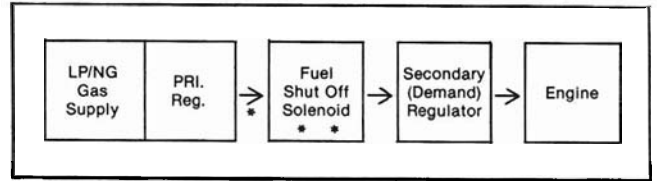

Figure 12

## LP/NG Fuel Adjustments

**NOTE:** Prior to making any adjustments, check the following:

1. Fuel pressure from the primary regulator, 4 to 6 oz. per square inch or 7 to 11 inches Water Column.



\*4 to 6 oz. or 7 to 11 inches water column.  
 \*\*Not furnished on some models.

2. Check fuel lines for correct size and condition.

### Size of Pipe Normally Required for WINCO Generators Operating on Natural Gas with BTU Content of 1000 BTU

Size in KW	10 ft.	30 ft.	50 ft.	100 ft.
15 KW to 18 KW	1 in.	1 in.	1¼ in.	1½ in.
10 to 12.5 KW	¾ in.	1 in.	1 in.	1¼ in.
7 KW to 9 KW	¾ in.	¾ in.	1 in.	1 in.
Up to 5 KW	¾ in.	¾ in.	¾ in.	1 in.

**NOTE:** Allow an additional 3 feet for each standard elbow. **DO NOT** use Street Ells.

On L.P. Gas units use ¾ in. pipe up to 50 feet in length on units up to 5 KW. On units from 5 KW to 18 KW use 1 in. pipe up to 50 feet in length.

3. Check spark plugs for condition and correct gap. (.25 to .030)
4. Check magneto point gap and engine timing.
5. Some regulators have vents located at the 5 and 7 o'clock positions. Check that these vents are not plugged.

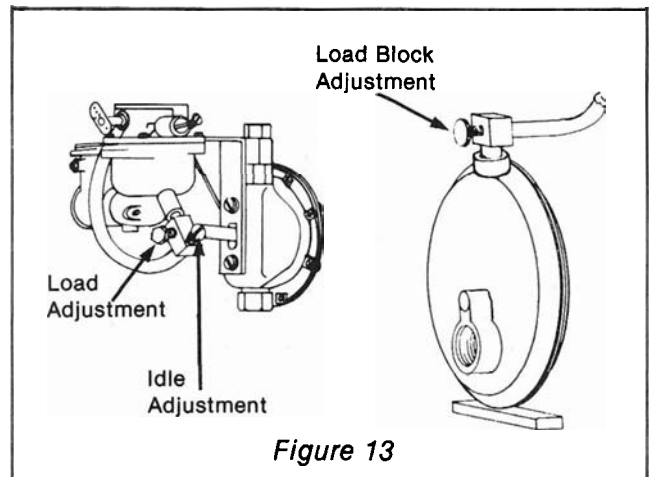

Figure 13

### Models with Gasoline Carburetor Conversion Kits

After the engine is running, apply a sufficient electrical load so that the generator is carrying its full rated load, or the maximum load for which it will be used. If the engine is not operating smoothly, a slight adjustment will be necessary to compensate for the different fuel BTU rating or atmospheric conditions of the area. Adjustments are made at the load block adjusting valve. The location of the load block will depend on the model of the engine generator set. Some are located on the secondary regulator (demand regulator), and some are located on the carburetor.

Loosen the locknut (if included) on the adjusting valve. Turn the adjusting screw open or closed so the engine runs smoothly at full load. Turn the screw clockwise to reduce the fuel, and counterclockwise to increase the fuel flow. Tighten the locknut after adjustment.

Some units operating at 1800 RPM, or units equipped with automatic idles, have an idling adjustment also. After the load adjustment has been made, remove the load and allow the engine to return to idle RPM. Adjust the idle needle screw for a smooth idle.

**NOTE:** Recheck full load and idle engine operation.

### Models with LP or Natural Gas Carburetion

On these models, the load adjustment valve and the idle adjustment screw are located on the carburetor. Adjustment procedures are the same as described for models with converted gasoline carburetors.

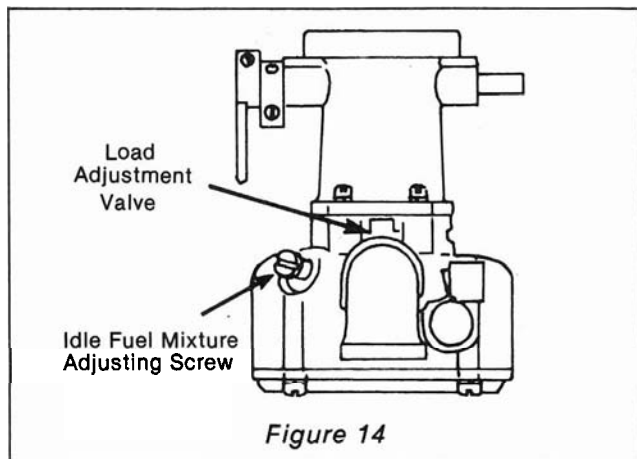

### Instructions for ETC Panels Equipped With Automatic Exerciser Clocks

This control is equipped with an exerciser clock to "exercise" the engine-generator set to insure its readiness when necessary. Since the clock must be set according to the day of the week and the hour of the day, it must be reset at the time of in-

stallation. It was checked at the factory to turn the plant on for approximately 15 minutes at 9:00 A.M. Monday. It can easily be reset to the customer's desires. A minimum of 15 minutes of exercising time per week is recommended.

#### **CAUTION**

The trip pins supplied with the exerciser clock have **left hand threads**.

These clocks have a 24-hour dial (large dial) with 15 minute settings—the inner row of holes for starting, and the outer row for stopping. A star dial located below and to the left of the hour dial is for setting the exercise day as desired.

**NOTE:** The star dial is a two week dial, and must be programmed for two weeks.

### Set Up Procedures

1. Turn the hour dial to the correct time of day.

#### **CAUTION**

Turn in a clockwise direction only.

2. Install a trip pin in the inner row of holes at the time desired for starting the engine-generator exercise period.
3. Install a trip pin in the outer row of holes at the time desired to stop the exercise period.
4. Install a trip pin in each of the spokes of the star dial *except* for the days the engine-generator is to be exercised.
5. Using the star dial (turning in a clockwise direction), turn until the correct day of the week is opposite the day pointer. Then set the 24-hour dial to the correct time of day.

<b>Table #1</b>										
		<b>Vapor Fuel Line Nom. Diameter @ 6 oz. (11" WC)</b>								
		5'	10'	25'	50'	100'	150'	200'	300'	
Air-Cooled	5KW	3/4"	3/4"	3/4"	3/4"	1"	1"	1 1/4"	1 1/4"	Recommended two stage regulator 10 lb. line, 3/8" diameter
	7KW	3/4"	3/4"	3/4"	1"	1"	1 1/4"	1 1/4"	1 1/2"	
	10KW	3/4"	3/4"	1"	1"	1 1/4"	1 1/4"	1 1/2"	1 1/2"	
	20KW	3/4"	1"	1"	1 1/4"	1 1/4"	1 1/4"	1 1/2"	1 1/2"	
Water-Cooled	25KW	3/4"	1"	1"	1 1/4"	1 1/4"	1 1/4"	1 1/2"	1 1/2"	
	35KW	3/4"	1"	1"	1 1/4"	1 1/4"	1 1/4"	1 1/2"	1 1/2"	
	45KW	3/4"	1"	1 1/4"	1 1/4"	1 1/2"	1 1/2"	2"	2"	
	55KW	1"	1 1/4"	1 1/2"	1 1/2"	2"	2"	2"	2 1/2"	
	65KW	1"	1 1/4"	1 1/2"	2"	2"	2"	2 1/2"	2 1/2"	

<b>Table #2</b>					
<b>Recommended Tank Size @ Various Temperatures for LP Vapor Withdrawal</b>					
	60° F	32° F	0° F	-20° F	
5KW	40	50	125	350 Gal.	Recommended Liquid Withdrawal
7KW	50	50	150	450 Gal.	
10KW	70	70	200	700 Gal.	
20KW	110	200	500	1,500 Gal.	
25KW	125	200	600	2,000 Gal.	
35KW	160	300	1,000	2,500 Gal.	
45KW	250	500	1,500	4,000 Gal.	
55KW	500	1,000	1,500	9,000 Gal.	
65KW	500	1,000	2,500	9,000 Gal.	

(24 Hour Supply Minimum)

<b>Table #3</b>						
<b>Fuel Consumption</b>						
	<b>Natural Gas</b>			<b>LP Vapor Propane</b>		
	@ 1,000 BTU/Cu. Ft.			@ 2,520 BTU/Cu. Ft.		
	Cu. Ft./Hr.	BTU/Hr.	#/Hr.	Gal./Hr.	Cu. Ft./Hr.	BTU/Hr.
5KW	125	125,000	7.1	1.7	61	153,000
7KW	177	177,000	8.3	2.0	71	179,000
10KW	250	250,000	11.2	2.7	96	242,000
20KW	465	465,000	19.4	4.6	166	419,000
25KW	470	470,000	22.0	5.2	188	475,000
35KW	550	550,000	28.0	6.6	239	604,000
45KW	770	770,000	38.5	9.1	329	830,000
55KW	920	920,000	46.0	12.2	431	960,000
65KW	1,255	1,255,000	63.0	14.9	539	1,358,000

## ***Local, State or NFPA Regulations***

### **Bibliography**

This manual is a guide to proper installation instructions. Listed below is a source of material to refer to for more detailed information:

NFPA Pamphlet #30—*Handling and Use of Flammable Liquids*

Fire Prevention Code

National Building Code

NFPA Pamphlet #70—*National Electrical Code*

NFPA Pamphlet #58—*Storage and Handling of Liquefied Petroleum Gases*

NFPA Pamphlet #54—*Installation of Gas Piping and Gas Appliances in Buildings*

NFPA Pamphlet #37—*Installation and Use of Internal Combustion Engines*

**WINCO**®

Division of  
**DYNA TECHNOLOGY, INC.**  
225 South Cordova  
LeCenter, MN 56057  
Phone (612) 357-6821