

TWO-BEARING GENERATOR

INSTALLATION AND
OPERATORS MANUAL



RECOGNIZED COMPONENT
CONFORMS TO
UL STD 1004-1
UL STD 1004-4

UL2FSM2PC-1/A

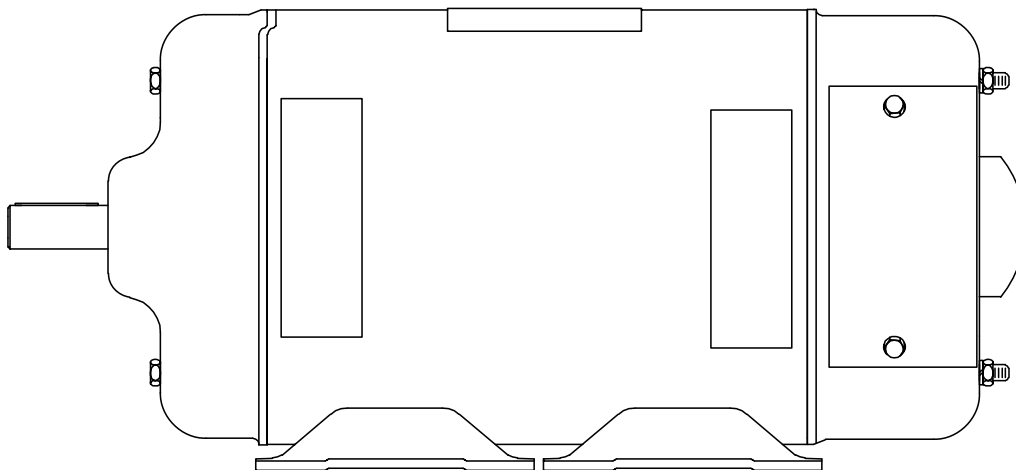

SAVE THESE INSTRUCTIONS

This manual contains important instructions that should be followed during installation and maintenance of the generator. Read and understand all instructions in the manual before starting and operating the generator set.

USING THE MANUAL

Congratulations on your choice of a Winco generator set. You have selected a high-quality, precision engineered generator set designed and tested to give you years of satisfactory service.

To get the best performance from your new generator set, it is important that you carefully read and follow the operating instructions in this manual.

Should you experience a problem please follow the "Troubleshooting Tables" near the end of this manual. The warranty listed in the manual describes what you can expect from WINCO should you need service assistance in the future.

TABLE OF CONTENTS

BASIC INFORMATION	
Specifications	2
GUIDE TO PRODUCT SAFETY	3
UNIT CAPABILITIES	4
PREPARING THE UNIT	5
Unit Installation	5
MAINTENANCE	6
ELECTRICAL TESTING	7
TROUBLESHOOTING	8
ILLUSTRATED PARTS LIST	9
WIRING DIAGRAM	10
MAINTENANCE LOG	11
WARRANTY INFORMATION	12

PROPER USE AND INSTALLATION

You must be sure your new generator set is:

- * Properly serviced before starting.
- * Operated in a well ventilated area.
- * Properly exhausted and gases safely dispersed.
- * Operated only for its designed purposes.
- * Used only by operators who understand its operation.
- * Properly maintained.

COPY YOUR MODEL AND SERIAL NUMBER HERE

No other WINCO generator has the same serial number as yours. It is important that you record the number and other vital information here. If you should ever need to contact us on this unit it will help us to respond to your needs faster.

MODEL _____

SERIAL NUMBER _____

PURCHASE DATE _____

DEALER _____

DEALER PHONE # _____

UNIT SPECIFICATIONS

GENERATOR

Surge Watts	2000
Continuous Watts	1260
Volts	120
Amps	16.6
Receptacles	2 - NEMA 5-15R
UL Listed	UL STD 1004-1 UL STD 1004-4

SAFETY INFORMATION

This engine generator set has been designed and manufactured to allow safe, reliable performance. Poor maintenance, improper or careless use can result in potential deadly hazards; from electrical shock, or fire. Please read all safety instructions carefully before installation or use. Keep these instructions handy for future reference. Take special note and follow all warnings on the unit labels and in the manuals.

ANSI SAFETY DEFINITIONS

DANGER:

DANGER indicates an imminently hazardous situation which, if not avoided, will result in death or serious injury. This signal word is to be limited to the most extreme situations.

WARNING:

WARNING indicates a potentially hazardous situation which, if not avoided, could result in death or serious injury.

CAUTION:

CAUTION indicates a potentially hazardous situation which, if not avoided, may result in minor or moderate injury. It may also be used to alert against unsafe practices.

NOTE:

CAUTION is also used on the unit labels and in this manual to indicate a situation that could result in serious damage or destruction of the equipment and possible personal injury.

1. ELECTRICAL SHOCK The output voltage present in this equipment can cause fatal electric shock. This equipment must be operated by a responsible person.

- a. Do not allow anyone to operate the generator without proper instruction.
- b. Guard against electric shock.
- c. Avoid contact with live terminals or receptacles.
- d. Use only three-pronged grounded receptacles and extension cords.
- e. Be sure the unit is properly grounded.

2. FIRE HAZARD Gasoline and other fuels present a hazard of possible explosion and/or fire.

- a. Do not refuel when the engine is running or hot.
- b. Keep fuel containers out of reach of children.
- c. Do not smoke or use open flame near the generator set or fuel tank.
- d. Keep a fire extinguisher nearby and know its proper use. Fire extinguishers rated ABC by NFPA are appropriate.
- e. Store fuel only in an approved container, and only in a well ventilated area.
- f. Follow local codes for closeness to combustible material.

3. NOISE HAZARD Excessive noise is not only tiring, but continual exposure can lead to loss of hearing.

- a. Use hearing protection when working around this equipment for long periods of time.

4. CLEANLINESS Keep the generator and surrounding area clean.

- a. Remove all grease, ice, snow or materials that create slippery conditions around the unit.
- b. Remove any rags or other materials that could create a potential fire hazard.
- c. Carefully clean up any gas or oil spills before starting the unit.

5. SERVICING EQUIPMENT All service, including the installation or replacement of service parts, should be preformed only by a qualified technician.

- a. Use only factory approved repair parts.
- b. Do not work on this equipment when fatigued.
- c. Never remove the protective guards, covers, or receptacle panels while the engine is running.
- d. Use extreme caution when working on electrical components. High output voltage from this equipment can cause serious injury or death.
- e. Always avoid hot mufflers, exhaust manifolds, and engine parts. They can cause severe burns instantly.
- f. The use of the engine-generator set must comply with all national, state, and local codes.

TESTING POLICY

Before any generator is shipped from the factory, it is fully checked for performance. The generator is loaded to its full capacity, and the voltage, current and frequency are carefully checked.

Rated output of generator is based on engineering tests of typical units, and is subject to, and limited by, the temperature, altitude, fuel, and other conditions specified by the manufacturer of the applicable engines.

UNIT CAPABILITIES

GENERATOR CONNECTIONS

This generator is designed for 120 volt alternating current (AC) use only. Two circuit breaker protected duplex outlets are provided for connection to various loads.

Check the appliance or tool nameplate for the current and voltage to insure compatibility. Although a circuit breaker is provided, damage due to overloading constitutes abuse and will not be warranted. Refer to the generator nameplate for unit's capabilities.

STARTING ELECTRIC MOTORS

Electric motors require much more current (amps) to start them than to run them. Some motors, particularly low cost split-phase motors, are very hard to start and require 5 to 7 times as much current to start them as to run them. Capacitor motors are easier to start and usually require 2 to 4 times as much current to start them as to run them. Repulsion Induction motors are the easiest to start and require 1 1/2 to 2 1/2 times as much to start them as to run them.

Most fractional horsepower motors take about the same amount of current to run them whether they are Repulsion Induction (RI), Capacitor (Cap), or Split-Phase (SP) type. The chart below shows the approximate current required to start and run various types and sizes of 120 volt 60 cycle electric motors under average load conditions.

HP	AMPS RUNNING	STARTING AMPS		
		SP	CAP	RI
1/6	3.2	16 to 22	6 to 13	5 to 8
1/4	4.5	22 to 32	9 to 18	7 to 12
1/3	5.2	26 to 35	10 to 21	8 to 17
1/2	7.2	not made	14 to 29	11 to 18
1	13.0	not made	26 to 52	20 to 33

The figures given above are an average load such as a blower or fan. If the electric motor is connected to a hard starting load such as an air compressor, it will require more starting current. If it is connected to a light load, or no load such as a power saw, it will require less starting current. The exact requirement will also vary with the brand or design of the motor.

Self-exciting generators respond to severe overloading differently than utility power. When overloaded, the engine is not able to supply enough power to bring the electric motor up to operating speed. The generator responds with high initial starting current, but the engine speed drops sharply. The overload may stall the engine. If allowed to operate at very low speeds, the electric motor starting winding will burn out in a short time. The generator winding might also be damaged.

CAUTION: EQUIPMENT DAMAGE

RUNNING THE GENERATOR SET UNDER THESE CONDITIONS MAY RESULT IN DAMAGING THE GENERATOR STATOR AS WELL AS THE MOTOR WINDING.

Because the heavy surge of current required for starting motors is required for only an instant, the generator will not be damaged if it can bring the motor up to speed in a few seconds of time. If difficulty is experienced in starting motors, turn all other electrical loads off and if possible reduce the load on the electric motor.

PREPARING THE UNIT

UNPACKING

CAUTION: EQUIPMENT DAMAGE

When you unpack your new generator be sure to remove all the information sheets and manuals from the carton.

1. This generator was in good order when shipped. Inspect the generator-set promptly after receiving it. If any damage is noted, notify the transportation company immediately; request proper procedures for filing a "concealed damage" claim. Title to the equipment and responsibility for filing a claim rests with you when a generator-set is sent F.O.B. shipping point. Only you can legally file a claim.

2. Before proceeding with the preparations of your new generator for operation, take a couple of minutes to insure the unit you have received is the correct model and review the specification pages in this manual to insure that this unit meets your job requirements.

UNIT INSTALLATION

CAUTION: EQUIPMENT DAMAGE

Before proceeding with the installation, be sure that you have completely read and understood the assembly and installation instructions.

An engine with adequate horsepower and a close regulated (fixed speed) governor is required for satisfactory operation of this generator.

About 1.4 horsepower is required to produce each 1,000 watts of generator output power assuming 100% efficiency of both the engine and the generator. However, due to engine and generator efficiencies of 80 to 90%, the loss of power due to engine driving accessories such as cooling fans, battery charging alternators, etc., friction losses and slippage in the drive pulleys and belts, the general conservative rule of thumb allowing approximately two (2) horsepower for every 1,000 watts of generator output is much more realistic. For example, this 2,000 watt generator output will require a 4 or 5 H.P. engine for full output, good speed/voltage regulation, and satisfactory load performance. When determining the prime mover/generator pulley ratio to drive the generator at the correct operating speed, bear in mind that the power rating of most prime movers (usually an engine) varies with the speed. It produces more power at higher speeds, less when slowed. The prime mover must be run fast enough

to reach the desired horsepower for good generator operation.

The drive belt system must be of adequate size and must be tight enough to power the generator without slippage. Be careful not to overtighten to the extent that it puts excessive strain on the bearings. Doing so can cause bearing failure and other possible damage to the generator.

Alignment of the generator to the prime mover is important. Misalignment of the pulleys will cause excessive belt and pulley wear and unnecessary stress on the prime mover.

The following table shows the effect of various operating speeds and electrical loads on a typical generator when matched and mounted to an adequate prime mover.

Although individual units and models may vary slightly, the normal voltage and frequency of typical 60 cycle engine-driven generators described in this manual are approximately as follows when powered by a typical prime mover (engine) run first with no load applied, then at half the generator capacity and finally when loaded to its full capacity as rated on the nameplate.

LOAD VS. OUTPUT			
Generator Load Applied*	Speed (RPM)	Frequency (Hz)	Voltage
None	3690	61.5	129V
Half	3600	60.0	120V
Full	3510	58.5	115V

* NOTE: Required generator speed must be maintained at 3600 +/- 90 RPM under all load conditions.

All engines have a tendency to slow down when a load is applied. The governor on the engine is designed to hold the engine speed nearly constant. When the electrical load connected to the generator is increased, the engine is more heavily loaded and as a result the speed drops slightly. This slight decrease in speed together with the natural "voltage drop" within the generator itself due to load current and heating of the windings, results in a slightly lower voltage than when the generator is running idle.

The normal slight variations in speed also directly affect the frequency of the output current. This frequency variation has no appreciable effect in the operation of most loads (such as motors, lights and most small appliances). However, timing devices and clocks will not keep perfect time unless the en-

gine can keep the generator running at exactly 3600 RPM at all times. Since this is not usually possible, minor time errors in clocks occur.

The speed of the engine is usually adjusted so that the generator produces proper voltage. If the adjustment is made "cold," set the voltage a little higher than normal since it will drop a few volts as the generator warms up.

NOTE: When operating continuously at full load the generator shell becomes very warm. It will be uncomfortable to the touch. This is normal for any high performance inherently regulated generator. Output voltage should be checked periodically to ensure proper operation of the generator and appliances.

CAUTION: EQUIPMENT DAMAGE

Low voltage may damage any motors or appliances connected to it. Running the generator at excessively high speeds results in too high voltage which will also damage electrical devices connected to it. Excessively high speed may also cause damage to the generator armature windings.

Plans for installation should be prepared with proper attention to mechanical and electrical engineering detail to assure a satisfactory system installation. The information in this manual is offered as a guide to finalizing your installation plans. The installation sequence is summarized below.

PLAN THE INSTALLATION

Generally these two-bearing generators are used on portable equipment. For best service consider the following:

1. All electrical equipment should be protected from excessive moisture. Failure to do so will result in deterioration of the insulation and short circuits and grounds.
2. The generator should be installed in a sheltered area. If the unit must be left in the open it should always be protected with a weather cover such as a tarp or large piece of canvas after each use to keep out water and dust.

CAUTION: EQUIPMENT DAMAGE

Always allow the generator and prime mover to cool before covering with a flammable weather covering.

MOUNTING

CAUTION: EQUIPMENT DAMAGE

The generator must be mounted with the engine to a common rigid base to prevent stress on the engine and generator shafts and bearings due to vibration displacement. For permanent installations, the engine-generator is usually mounted on a sub-frame which can be shock mounted with special neoprene pads on the main frame.

MAINTENANCE

GENERAL

The main components of the generator are: field frame, field coils, armature, brushes, brush holder assembly, brackets, armature, and generator cooling fan.

BRUSHES

Under ordinary circumstances brushes will operate for thousands of hours without requiring replacement. They should be inspected after the first 1000 hours of operation, and after every 500 hours of operation thereafter. Remove brushes one at a time and check for length. Be sure that each moves freely in the brush holder. Brushes should be replaced when worn down to 3/8". Always replace brushes in complete sets, never singularly. When replacing brushes be careful to reconnect the lead wire properly. Poor contact or "skipping" between brush and slip ring can be caused by oil and grit, flint, or other hard contaminant substances on the brushes, or by the brush not being properly shaped to fit the slip rings.

Remedy these defects by cleaning the rings and brushes and then fitting the brushes to the slip ring curvature. Place #00 sandpaper under the brushes with the abrasive side to the brushes, and work it back and forth until the brushes are the same shape as the slip rings.

SLIP RINGS

The continuous copper rings located at the end of armature are the power collector rings or 'slip rings'. For proper generator output, the surface of these slip rings must have a highly polished finish. Under sustained use, it is advisable to check and occasionally polish ring surfaces with a crocus cloth to maintain the finish under normal conditions. This should not be required more than once each thousand hours of operation.

ELECTRICAL TESTING

Testing the generator for opens and grounds.

1. Disconnect field leads from rectifier.
2. Set multi-meter to read resistance, and connect the meter leads to the field leads. If field is open, meter will read infinite resistance (very high ohms), repair or replace field if it is open. Typical resistance for these fields varies from 12.8 to 14.1 ohms.
3. Leaving one meter lead connected to the field, connect the other meter lead to the field shell. If meter indicates continuity (any reading - should be infinite resistance), the field is grounded and should be repaired or replaced. To determine which of the fields is grounded, cut the connector between the two coils and retest to determine which coil has the low resistance path.

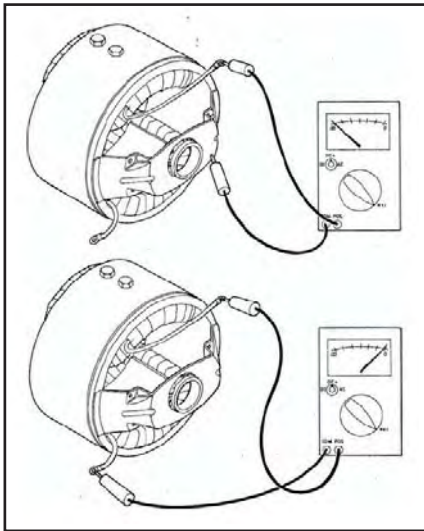

TESTING ARMATURE FOR OPENS AND GROUNDS

1. Remove all brushes.
2. Ground fault test. Set multi-meter to read high resistance (mega-ohms). Holding one meter lead against a clean spot on the armature shaft, touch the other lead to each of the slip rings (one at a time) while observing the meter. If meter indicates continuity (any reading lower than one mega-ohm), the armature is grounded. Dirt between the slip rings and on the insulator surface can cause grounding. If grounding was indicated, carefully clean all dirt off the slip rings and their insulators and then recheck it. Replace the armature if it is grounded and unreparable.
3. Testing for opens. Set meter to read low resistance ($R \times 1$ ohms). Holding one meter lead on the surface of slip ring # 1, touch the other lead to surface of slip ring # 2 while observing the meter. Meter should indicate continuity (low resistance - less than one ohm is typical). If the meter indicates an open

circuit (infinite resistance) part of the armature winding is open. This may be caused by a repairable defect in the connection at the slip ring, however generally an open armature will have to be replaced.

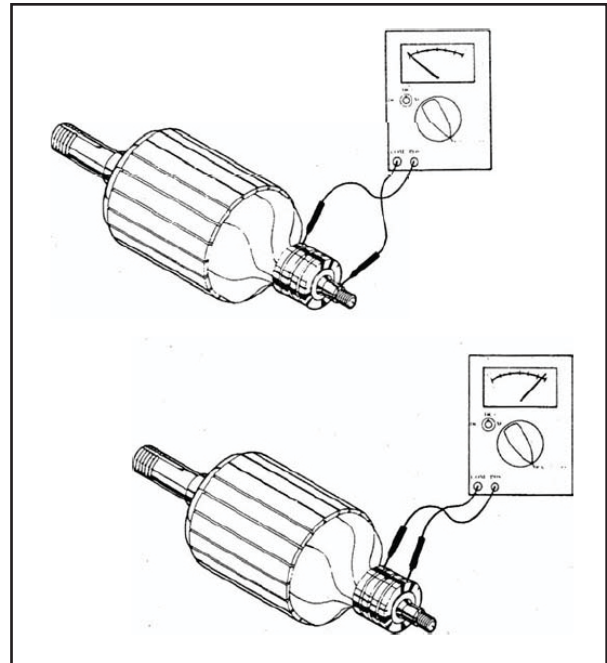

TESTING RECTIFIERS

The field excitation is supplied through full wave bridge rectifier. This type of rectifier has four terminals: two AC and a DC positive (+) and DC negative (-). Nothing is connected to the DC negative (-) in this generator.

A rectifier may be tested in the following manner:

1. Disconnect all leads from rectifier.
2. Connect the red ohmmeter lead to the positive DC (+) terminal.
3. Connect the black lead to each of the AC terminals in turn. Either a high or low resistance reading will be obtained.
4. Reverse the meter lead, (black lead to the DC positive (+) and red to the AC terminals, each in turn. An opposite reading should be observed.
5. Check each terminal to the case. An open circuit (very high resistance) reading should be observed. If a battery powered test light is used follow the same procedures described above. A good diode element will allow current to pass to the light in the test lamp when the lead are connected in the forward direction.
6. If the rectifier fails any of the above tests, it should be considered defective and replaced.

TROUBLESHOOTING CHART

SYMPTOM	POSSIBLE CAUSE(S)	CORRECTIVE ACTION
No output or low voltage.	<ol style="list-style-type: none"> 1. Open or shorted armature. 2. Open or grounded field coil(s). 3. Generator operating below correct RPM speed. 4. Generator overloaded. 5. Short circuit in the load. 6. Loose (or broken) wires or connections in the control box. 7. Defective rectifier. 8. Dirty slip rings. 9. Brushes binding in holders. 10. Loss of residual magnetism. 	<ol style="list-style-type: none"> 1. Replace armature. 2. Replace field coil(s). 3. Generator must be operated at 3600 RPM +/- 90 RPM for proper output voltage. 4. Reduce load to generator nameplate. 5. Disconnect the load. Check motors, appliances and load leads for short circuits. Repair short. 6. Remove panel cover and check all wiring and connections. Tighten and/or repair where necessary. 7. Test rectifier. Replace if defective. 8. Clean and polish. Use 00 sandpaper and crocus cloth, never emery paper. 9. Check brushes for swelling. Replace defective brushes. Clean brush holders. 10. Check output voltage with sensitive meter. If very low (i.e. 1/2 volt) flash fields with a 12 VDC battery.
Output voltage too high.	Engine speed too high.	See engine manual.
Generator overheating.	<ol style="list-style-type: none"> 1. Generator overloaded. 2. Armature rubbing pole shoes. 3. Poor ventilation. 4. Short circuit in fields. 5. Short turns in armature. 	<ol style="list-style-type: none"> 1. Reduce load. 2. Check bearing condition. Check field shell bearing bracket alignment. 3. Clear inlet and outlet air vents of debris. If unit is housed, ensure at least 2 ft. clearance on all sides and that inlet and outlet vents are of adequate size. 4. Repair or replace - open or shorted fields should be replaced. Grounded fields may be repaired by insulating at the point where the ground occurs. 5. Replace armature.
Sparking at the brushes.	<ol style="list-style-type: none"> 1. Generator overloaded. 2. Brushes not seated properly. 3. Slip rings rough or eccentric. 4. Brushes sticking in brush holder. 5. Brushes worn down shorter than 3/8 inch. 	<ol style="list-style-type: none"> 1. Reduce load. 2. Contour brushes (see maint.). 3. Redress slip rings (see maint.). 4. Remove brushes and inspect and correct problem. 5. Replace brush. NOTE: Always replace brushes a full set at a time.

ILLUSTRATED PARTS LIST

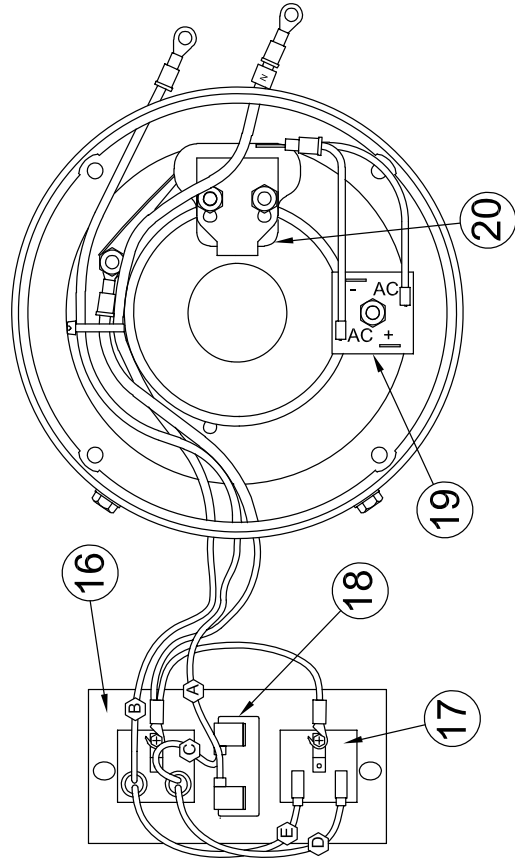
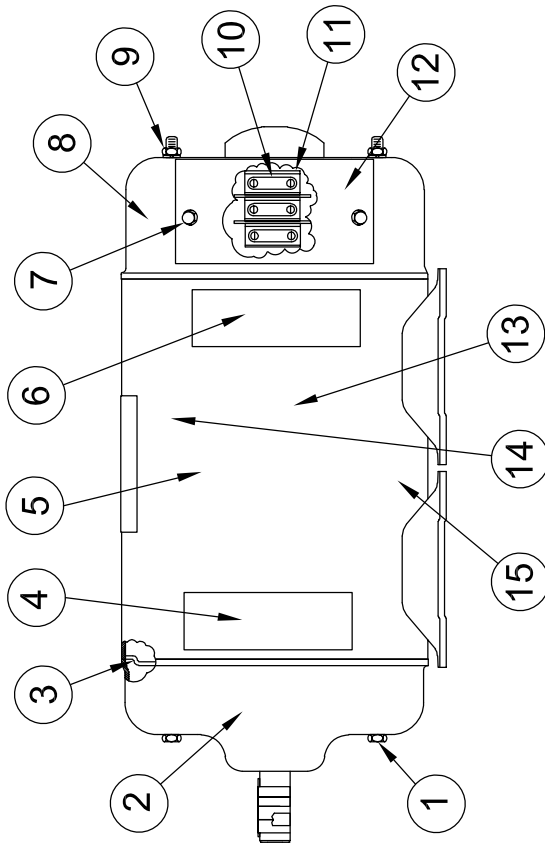

REF #	PART NUMBER	QTY	DESCRIPTION
1	20556-002	4	# 10-32 Thru Bolt
2	8929-000	1	End Bracket
3	7924-000	1	Baffle
4	64917-002	1	UL Decal
5	61689-000	1	Field Shell & Base Assy.
6	63941-008	1	Hot Surface Decal
7	53644-000	4	Screw
8	61427-000	1	Output Shaft End Bracket
9	6372-000	4	Hex Nut
10	23607-000	3	AC Brush
11	59690-000	3	AC Brush Holder
12	60928-000	1	Cover Plate
13	60931-001	1	Receptacle Cover Plate
14	61426-000	1	Armature & Bearing Assy.
15	60925-000	1	Upper Field Coil
16	60925-001	1	Lower Field Coil
17	60960-000	2	Receptacle
18	91286-015	1	15 Amp Circuit Breaker
19	53976-000	1	Rectifier
20	59688-000	3	Barrier Spacer
NI	23532-000	1	Spacer
NI	41384-017	1	Copper Strap
NI	40746-000	6	# 8-32 X 5/16 Screw
NI	21361-000	1	Key
NI	61687-000	1	Field Shell & Coil Assy.
NI	55223-000	2	Bearing
NI	Not Illustrated		

WIRING DIAGRAM

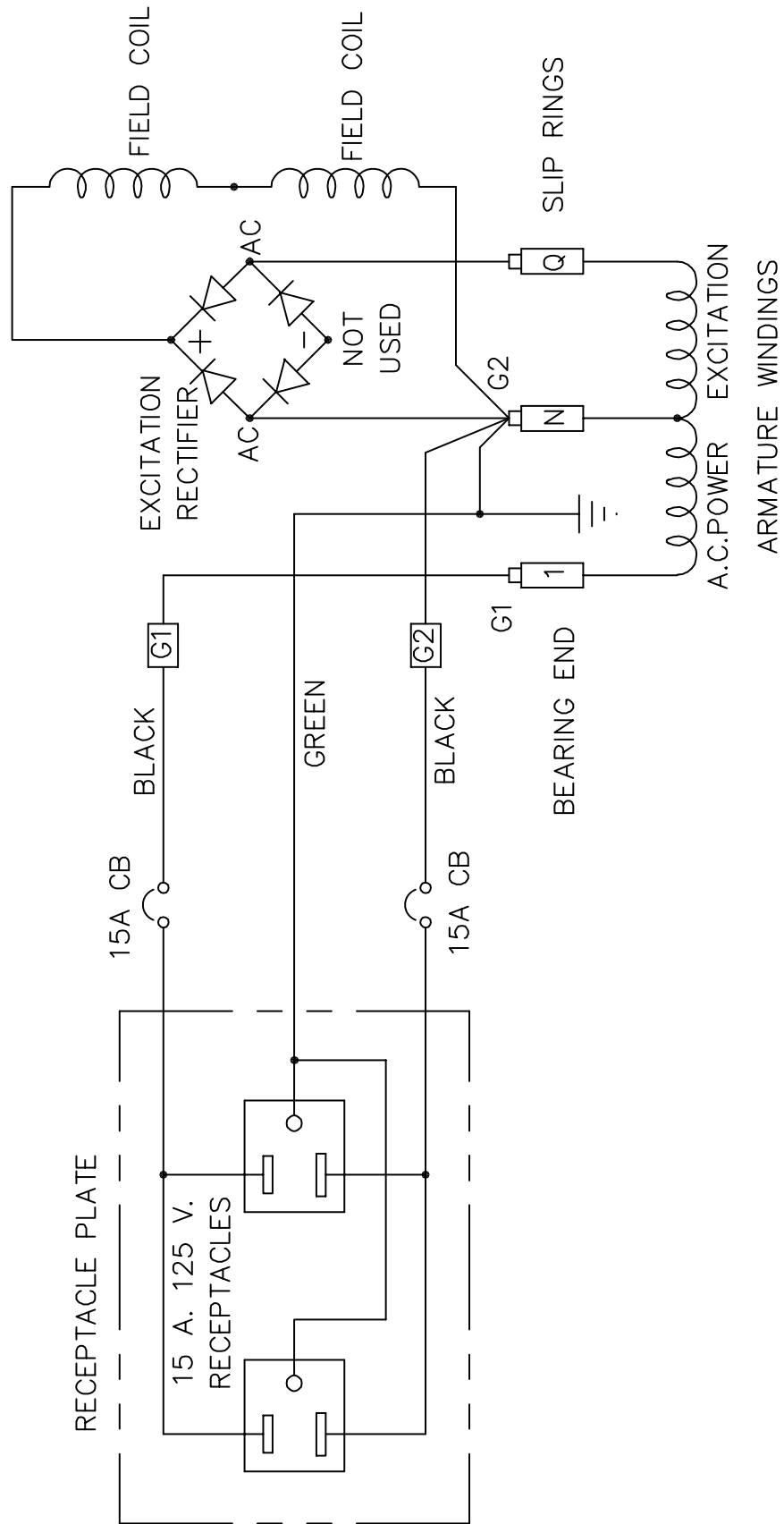



12 MONTH LIMITED WARRANTY

WINCO, Incorporated warrants to the original purchaser for 12 months that goods manufactured or supplied by it will be free from defects in workmanship and material, provided such goods are installed, operated and maintained in accordance with WINCO written instructions.

WINCO's sole liability, and Purchaser's sole remedy for a failure under this warranty, shall be limited to the repair of the product. At WINCO's option, material found to be defective in material or workmanship under normal use and service will be repaired or replaced. For warranty service, return the product within 12 months from the date of purchase, transportation charges prepaid, to your nearest WINCO Authorized Service Center or to WINCO, Inc. at LeCenter Minnesota.

THERE IS NO OTHER EXPRESS WARRANTY.

To the extent permitted by law, any and all warranties, including those of merchantability and fitness for a particular purpose, are limited to 12 months from date of purchase. In no event is WINCO liable for incidental or consequential damages.

Note: Some states do not allow limitation on the duration of implied warranty and some states do not allow the exclusion or limitation of incidental or consequential damages, so the above limitations may not apply in every instance. This warranty gives you specific legal rights which may vary from state to state.

WINCO reserves the right to change or improve its products without incurring any obligations to make such changes or improvements on products purchased previously.

EXCLUSIONS:

WINCO does not warrant Engines. Engines are covered exclusively by the warranties of their respective manufacturers, see enclosed warranties.

WINCO does not warrant Component Parts that are warranted by their respective manufacturers.

WINCO does not warrant modifications or alterations which were not made by WINCO Inc.

WINCO does not warrant products which have been subjected to misuse and/or negligence or have been involved in an accident.

This warranty does not include travel time, mileage, or labor for removal or reinstallation of WINCO product from its application.