

# INDUSTRIAL PORTABLE

## INSTALLATION AND OPERATORS MANUAL

# W3000H

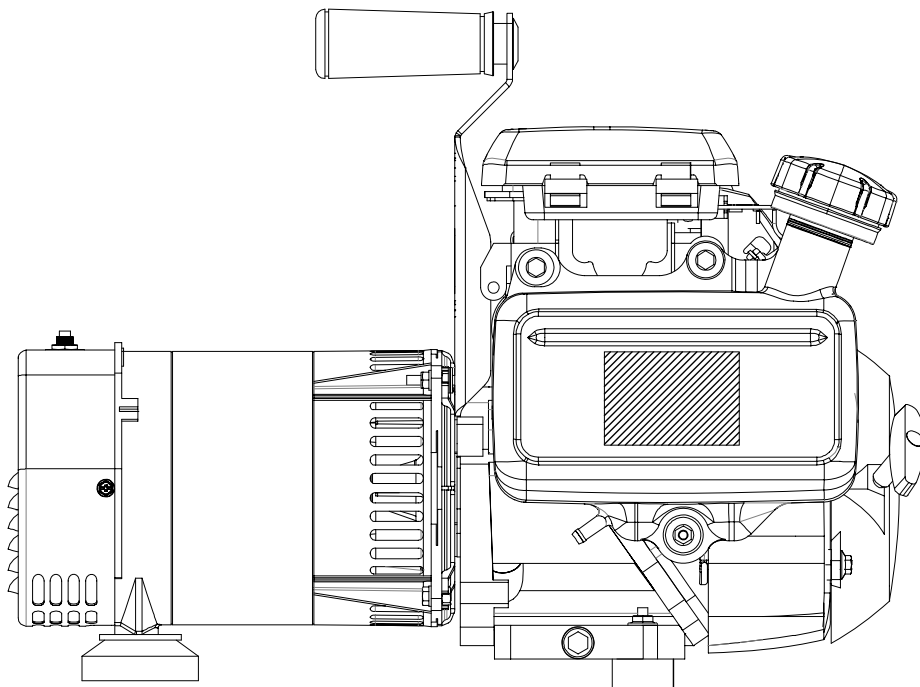

## SAVE THESE INSTRUCTIONS

This manual contains important instructions that should be followed during installation and maintenance of the generator and battery. Read and understand all instructions in the manual before starting and operating the generator set.

## USING THE MANUAL

Congratulations on your choice of a Winco generator set. You have selected a high-quality, precision engineered generator set designed and tested to give you years of satisfactory service.

To get the best performance from your new engine generator set, it is important that you carefully read and follow the operating instructions in this manual.

Should you experience a problem please follow the "Troubleshooting Tables" near the end of this manual. The warranty listed in the manual describes what you can expect from WINCO should you need service assistance in the future.

## TABLE OF CONTENTS

INTRODUCTION	2
BASIC INFORMATION	
Specifications	2
Unit Capabilities	4
GUIDE TO PRODUCT SAFETY	3
PREPARING THE UNIT	
Unpacking the Unit	5
Unit Preparation	5
Initial Start Up	6
Basic Operation	6
ENGINE CARE	7
GENERATOR CARE	8
TROUBLESHOOTING	9
WARRANTY INFORMATION	10
MAINTENANCE LOG	11

## PROPER USE AND INSTALLATION

You must be sure your new engine generator set is:

- \* Properly serviced before starting.
- \* Operated in a well ventilated area.
- \* Properly exhausted and gases safely dispersed.
- \* Operated only for its designed purposes.
- \* Used only by operators who understand its operation.
- \* Properly maintained.

## COPY YOUR MODEL AND SERIAL NUMBER HERE

No other WINCO generator has the same serial number as yours. It is important that you record the number and other vital information here. If you should ever need to contact us on this unit it will help us to respond to your needs faster.

MODEL \_\_\_\_\_

SERIAL NUMBER \_\_\_\_\_

PURCHASE DATE \_\_\_\_\_

DEALER \_\_\_\_\_

DEALER PHONE # \_\_\_\_\_

## UNIT SPECIFICATIONS

### GENERATOR

Surge Watts	3000
Continuous Watts	2400
Volts	120
Amps	20
Receptacle	
NEMA 5-20R	20A Duplex GFCI

### ENGINE

Model	HONDA
Horse Power	GC160AVXA
Fuel Capacity	5
Oil Capacity	.48 gal.
Oil Grade	20 oz.
	SAE 10W-30 (General Use)

# SAFETY INFORMATION

This engine generator set has been designed and manufactured to allow safe, reliable performance. Poor maintenance, improper or careless use can result in potential deadly hazards; from electrical shock, exhaust gas asphyxiation, or fire. Please read all safety instructions carefully before installation or use. Keep these instructions handy for future reference. Take special note and follow all warnings on the unit labels and in the manuals.

## ANSI SAFETY DEFINITIONS

\*\*\*\*\*

### DANGER:

*DANGER indicates an imminently hazardous situation which, if not avoided, will result in death or serious injury. This signal word is to be limited to the most extreme situations.*

\*\*\*\*\*

\*\*\*\*\*

### WARNING:

*WARNING indicates a potentially hazardous situation which, if not avoided, could result in death or serious injury.*

\*\*\*\*\*

\*\*\*\*\*

### CAUTION:

*CAUTION indicates a potentially hazardous situation which, if not avoided, may result in minor or moderate injury. It may also be used to alert against unsafe practices.*

\*\*\*\*\*

### NOTE:

*CAUTION is also used on the unit labels and in this manual to indicate a situation that could result in serious damage or destruction of the equipment and possible personal injury.*

**1. ELECTRICAL SHOCK** The output voltage present in this equipment can cause fatal electric shock. This equipment must be operated by a responsible person.

- a. Do not allow anyone to operate the generator without proper instruction.
- b. Guard against electric shock.
- c. Avoid contact with live terminals or receptacles.
- d. Use extreme care if operating this unit in rain or snow.
- e. Use only three-pronged grounded receptacles and extension cords.
- f. Be sure the unit is properly grounded to an external ground rod driven into the earth.

**2. FIRE HAZARD** Gasoline and other fuels present a hazard of possible explosion and/or fire.

- a. Do not refuel when the engine is running or hot.
- b. Keep fuel containers out of reach of children.
- c. Do not smoke or use open flame near the generator set or fuel tank.
- d. Keep a fire extinguisher nearby and know its proper use. Fire extinguishers rated ABC by NFPA are appropriate.
- e. Store fuel only in an approved container, and only in a well ventilated area.
- f. Follow local codes for closeness to combustible material.

**3. DEADLY EXHAUST GAS** Exhaust fumes from any gasoline engine contain carbon monoxide, an invisible, odorless and deadly gas that must be mixed with fresh air.

- a. Operate only in well ventilated areas.
- b. Never operate indoors.
- c. Never operate the unit in such a way as to allow exhaust gases to seep back into closed rooms (i.e. through windows, walls, floors).

**4. NOISE HAZARD** Excessive noise is not only tiring, but continual exposure can lead to loss of hearing.

- a. Use hearing protection when working around this equipment for long periods of time.
- b. Keep your neighbors in mind when permanently using this equipment.

**5. CLEANLINESS** Keep the generator and surrounding area clean.

- a. Remove all grease, ice, snow or materials that create slippery conditions around the unit.
- b. Remove any rags or other materials that could create a potential fire hazard.
- c. Carefully clean up any gas or oil spills before starting the unit.

**6. SERVICING EQUIPMENT** All service, including the installation or replacement of service parts, should be preformed only by a qualified technician.

- a. Use only factory approved repair parts.
- b. Do not work on this equipment when fatigued.
- c. Never remove the protective guards, covers, or receptacle panels while the engine is running.
- d. Use extreme caution when working on electrical components. High output voltage from this equipment can cause serious injury or death.

- e. Always avoid hot mufflers, exhaust manifolds, and engine parts. They can cause severe burns instantly.
- f. The use of the engine-generator set must comply with all national, state, and local codes.

## TESTING POLICY

Before any generator is shipped from the factory, it is fully checked for performance. The generator is loaded to its full capacity, and the voltage, current and frequency are carefully checked.

Rated output of generator is based on engineering tests of typical units, and is subject to, and limited by, the temperature, altitude, fuel, and other conditions specified by the manufacturer of the applicable engines.

## INTENDED USES

These engine generator sets have been designed primarily for portable use. A 120 volt GFCI AC receptacle is provided in the end cover to connect your loads (lights, portable tools, and small appliances).

This portable unit requires large quantities of fresh air for cooling the engine and generator. For safety, long life and adequate performance, these units should never be run in small compartments without positive fresh air flow.

## RESTRICTED USES

**DO NOT** install and operate this generator in a small compartment., i.e. generator compartments of vehicles, motor homes or travel trailers. These compartments will not allow enough free flow of fresh air to reach the engine generator set for cooling and will cause the unit to overheat damaging both the engine and generator. Small compartments will also develop hot spots where there is very little air flow and may cause a fire.

**PLEASE NOTE** There are 3rd party companies making enclosures for generators that have been properly engineered. The use of these 3rd party enclosures is acceptable as long as they have been certified and meet current code.

**DO NOT** attempt to operate at 50 cycles. These units are designed and governed to operate at 60 cycles only.

## UNIT CAPABILITIES

### GENERATOR CONNECTIONS

This generator is designed for 120 volt alternating current (AC) use only. A GFCI protected duplex outlet is provided for connection to various loads.

Check the appliance or tool nameplate for the current and voltage to insure compatibility. Although a circuit breaker is provided, damage due to overloading constitutes abuse and will not be warranted. Refer to the generator nameplate for unit's capabilities.

### STARTING ELECTRIC MOTORS

Electric motors require much more current (amps) to start them than to run them. Some motors, particularly low cost split-phase motors, are very hard to start and require 5 to 7 times as much current to start them as to run them. Capacitor motors are easier to start and usually require 2 to 4 times as much current to start them as to run them. Repulsion Induction motors are the easiest to start and require 1 1/2 to 2 1/2 times as much to start them as to run them.

Most fractional horsepower motors take about the same amount of current to run them whether they are Repulsion Induction (RI), Capacitor (Cap), or Split-Phase (SP) type. The chart below shows the approximate current required to start and run various types and sizes of 120 volt 60 cycle electric motors under average load conditions.

HP	AMPS RUNNING	STARTING AMPS		
		SP	CAP	RI
1/6	3.2	16 to 22	6 to 13	5 to 8
1/4	4.5	22 to 32	9 to 18	7 to 12
1/3	5.2	26 to 35	10 to 21	8 to 17
1/2	7.2	not made	14 to 29	11 to 18
1	13.0	not made	26 to 52	20 to 33

The figures given above are an average load such as a blower or fan. If the electric motor is connected to a hard starting load such as an air compressor, it will require more starting current. If it is connected to a light load, or no load such as a power saw, it will require less starting current. The exact requirement will also vary with the brand or design of the motor.

Self-exciting generators respond to severe overloading differently than utility power. When overloaded, the engine is not able to supply enough power to bring the electric motor up to operating speed. The generator responds with high initial starting current, but the engine speed drops sharply. The overload may stall the engine. If allowed to operate at very low speeds, the electric motor starting winding will burn out in a short time. The generator winding might also be damaged.

#### **CAUTION: EQUIPMENT DAMAGE**

*RUNNING THE GENERATOR SET UNDER THESE CONDITIONS MAY RESULT IN DAMAGING THE GENERATOR STATOR AS WELL AS THE MOTOR WINDING.*

Because the heavy surge of current required for starting motors is required for only an instant, the generator will not be damaged if it can bring the motor up to speed in a few seconds of time. If difficulty is experienced in starting motors, turn all other electrical loads off and if possible reduce the load on the electric motor.

## **PREPARING THE UNIT**

### **UNPACKING**

#### **CAUTION: EQUIPMENT DAMAGE**

*THIS UNIT HAS BEEN SHIPPED WITHOUT OIL. Failure to maintain the engine oil at the proper level will result in serious engine damage.*

When you unpack your new engine-generator set be sure to remove all the information sheets and manuals from the carton.

1. This generator-set was in good order when shipped. Inspect the generator-set promptly after receiving it. If any damage is noted, notify the transportation company immediately; request proper procedures for filing a "concealed damage" claim. Title to the equipment and responsibility for filing a claim rests with you when a generator-set is sent F.O.B. shipping point. Only you can legally file a claim.
2. Before proceeding with the preparations of your new generator-set for operation, take a couple of minutes to insure the unit you have received is the correct model and review the specification pages in this manual to insure that this unit meets your job requirements.

## **UNIT PREPARATION**

Before your generator-set was shipped from our factory it was fully checked for performance. The generator was load tested to its full capacity, and the voltage and frequency were carefully checked and adjusted.

### **LUBRICATION**

Before starting the engine, fill the crankcase to the proper level with a good quality oil. The recommended grade of oil and quantity of oil required is listed in the engine operator's manual. The necessity of using the correct oil, and keeping the crankcase full cannot be overemphasized. Engine failures resulting from inadequate or improper lubricant are considered abuse and not covered by the generator or engine manufacturer's warranty.

### **GASOLINE**

When using gasoline always use a good grade of unleaded fuel. This engine is certified to operate on unleaded gasoline with a pump octane rating of 86 or higher. Gasoline containing no more than 10% ethanol (E10) or 5% methanol by volume may be used. In addition methanol must contain co-solvents and corrosion inhibitors. Use of fuels with content of ethanol or methanol greater than shown above may cause starting and/or performance problems. Always insure that the fuel is clean and free of all impurities.

#### **WARNING: FIRE DANGER**

*Gasoline and its fumes are VERY explosive when proper precautions are not taken.*

Never use gasoline that has been stored for an extended period of time as the fuel will lose its volatile properties and you will be left with only the varnish residue. The varnish like substance will clog the carburetor and will not burn properly.

The use of fuel additives, such as STA-BIL, or an equivalent will minimize the formation of fuel gum deposits. If a unit has been out of operation for an extended period of time it is best to drain old fuel from the engine and replace with fresh fuel before attempting to start.

### **OIL ALERT SYSTEM**

The Oil Alert system is designed to prevent engine damage caused by insufficient amount of oil in the crankcase. Before the oil level in the crankcase can fall below a safe limit, the Oil Alert system will automatically stop the engine.

## INITIAL START UP

The throttle control on these generators is preset and locked to operate at 3600 RPM (nominal) with no load speed set at 3720 RPM. Only a trained service technician should be allowed to adjust this speed setting.

### NOTICE: ENGINE START LOCKOUT

*This unit **will not start** if it is low on oil. The lubricating oil level must be at the **full** mark before the engine will start and run.*

## BASIC OPERATION

**Manual starting** - Refer to the engine manual for additional starting, operating, and stopping instructions.

1. Pull the choke rod out to the choke position.
2. Move the on/off lever to the on position.
3. Pull the starter grip lightly until resistance is felt, then pull briskly.

### NOTICE:

*Do not allow the starter grip to snap back against the engine. Return it gently to prevent damage to the starter.*

4. If the choke rod was pulled to the CLOSED position to start the engine, push it to the OPEN position as soon as the engine warms up enough to run smoothly.

### CAUTION: EQUIPMENT DAMAGE

*Never permit the choke to remain on after the engine has run for a short time. It is not necessary to choke the engine when it is warm. Avoid over-choking.*

## STARTING HINTS

1. Cold weather
  - a. Use the proper oil for the temperature expected.
  - b. Use fresh winter grade fuel. Winter grade gasoline is blended to improve starting. Do not use summer gasoline.
  - c. A slightly richer fuel mixture will usually improve cold starting.
2. Hot weather
  - a. Use the proper oil for the temperature expected.
  - b. Use only summer blended gasoline. Using gasoline left over from winter may cause the unit to vapor lock.

## STOPPING AND STORAGE

1. Move the on/off lever to the off position.
2. Before extended storage (over 30 days) certain precautions must be taken care of to ensure the fuel doesn't deteriorate and clog the fuel system. Note: The use of a fuel additive, such as STA-BIL or an equivalent will minimize the formation of gum deposits during storage. Such an additive may be added to gasoline in the engines fuel tank or to gasoline in a storage container.
  - a. Remove the remaining fuel from the fuel tank.
  - b. Start the engine and allow it to run until all the fuel in the carburetor and the fuel lines has been used up and the engine stops.
  - c. While the engine is warm, drain the oil and refill with fresh oil.
  - d. Remove the spark plug, pour approximately 1/2 ounce (15 cc) of engine oil into the cylinder and crank slowly to distribute the oil. Replace the spark plug.
  - e. Clean dirt and chaff from cylinder, cylinder head fins, blower housing, screen and muffler areas.
  - f. Store in a clean and dry area.

## OPERATING SPEED

The engine-generator must be run at the correct speed in order to produce the proper electrical voltage and frequency.

### CAUTION: EQUIPMENT DAMAGE

*The output voltage should be checked to insure the generator is working properly prior to connecting a load to the generator. Failure to do so could result in damage to equipment plugged into the unit and possible injury to the individual.*

All engines have a tendency to slow down when a load is applied. When the electrical load is connected to the generator, the engine is more heavily loaded, and as a result the speed drops slightly. This slight decrease in speed, together with the voltage drop within the generator itself, results in a slightly lower voltage when the generator is loaded to its full capacity than when running no load. The slight variation in speed also affects the frequency of the output current. This frequency variation has no appreciable effect in the operation of motors, lights and most appliances. However, electronic equipment and clocks will be affected if correct RPM is not maintained. See Load vs. Output chart.

Although individual units and models vary slightly, the normal voltage and frequency of the engine-generator described in this manual are approximately as follows, under varying loads:

LOAD VS. OUTPUT			
Generator Load Applied*	Speed (RPM)	Frequency (Hz)	Voltage
None	3690	61.5	125V
Half	3600	60.0	120V
Full	3510	58.5	115V

\* Portion of plant's rated output current.

The speed of the engine was carefully adjusted at the factory so that the generator produces the proper voltage and frequency. For normal usage, the speed setting should not be changed. If the generator is being run continuously on a very light load, it is often advisable to lower the operating speed slightly. Whenever making any speed adjustments check the unit with a voltmeter or tachometer and be sure the speed is correct.

Lower voltage may damage both the generator and any load connected to it. Running the engine at excessively high speeds results in high voltage, which may significantly shorten the life of appliances being used.

Output voltage should be checked periodically to ensure continued proper operation of the generating plant and appliances. If the generator is not equipped with a voltmeter, it can be checked with a portable meter. Frequency can be checked by using an electric clock with a sweep second hand. Timed against a wrist watch or a stop watch, the clock should be correct within +/- 2 seconds per minute.

## CONNECTING THE LOADS

### APPLYING THE LOADS

Allow the engine to warm up for two or three minutes before applying any load. This will allow the engine to reach normal operating temperature and oil to circulate throughout the engine. A short warm-up time will permit the engine to work more efficiently when the load is applied and will reduce the wear in the engine, extending its life.

Receptacles have been provided to allow loads to be connected to the generator. The loads should be added one at a time. If a large motor is being started or multiple motors are being started, they should be started individually and the largest should be started first.

### CAUTION: EQUIPMENT OVERLOAD

Keep the generator load within the generator and

receptacle nameplate rating. Overloading may cause damage to the generator and/or the loads. Most electric tools and appliances will have the voltage and amperage requirements on their individual nameplates. When in doubt consult the manufacturer or a local electrician. The nameplate amperage rating for electric motors can be misleading. See "Starting Electric Motors" in Unit Capabilities (page 4).

These engine-generator sets are inherently self regulating based on engine speed. The engine governor will automatically adjust itself to the load. No harm to the generator will result if it is operated with no load connected. Proper utilization of the receptacles located on the control panel is necessary to prevent damage to either the receptacles or the generator. The generator is a limited source of electrical power, therefore pay special attention to the receptacle and generator ratings. The nameplate rating can be obtained through a single receptacle as long as the receptacle amperage rating is not exceeded.

## GROUNDING

All units must be grounded. Drive a 3/4 or 1" copper pipe or rod into the ground close to the engine-generator set. The pipe must penetrate moist earth. Connect an approved ground clamp, to the pipe. Run a no. 10 Awg wire from clamp to the generator ground lug on the "end cover". Do not connect to a water pipe or to a ground used by a radio system. The engine-generators covered in this manual were designed for portable use. **DO NOT OPERATE THIS GENERATOR INDOORS.** The unit should be stored in a warm dry location. During a power outage, move the unit outdoors to a flat dry location such as a driveway or sidewalk. Many homes today are wired for at least 60 to 100 Amp entrance service, much greater than the capacity of these portable generators. Do not attempt to power a home with portable generator. This generator set is suitable for powering individual appliances or emergency lighting.

## ENGINE CARE

If major engine service or repair is required contact an authorized engine service center. The manufacturer of these engines has established an excellent world-wide engine service organization. Engine service is very likely available from a nearby authorized dealer or distributor. Check the yellow pages of your local telephone directory under "Engines-Gasoline" for the closest engine repair center or ask the dealer from whom you purchased the power plant.

1. **Change the oil** after the first five hours of operation and every 50 hours thereafter under normal operating conditions. Change engine oil every 25 hours of operation if the engine is operated under heavy load, or in high ambient temperatures.

- a. Remove oil drain plug at base of the engine and drain the oil with the engine warm.
- b. Replace oil drain plug.
- c. Remove oil filler plug and refill with new oil. Refer to the table in the engine manual for the proper grade of oil based on your operating temperature.
- d. Replace filler plug.

2. **Checking the Oil Level:** The oil level must always be checked before the engine is started. Take care to remove any dirt or debris from around the oil fill plug before removing. Be sure the oil level is maintained. Fill to the **"FULL"** mark on the dipstick.

3. **Cartridge Air Cleaner** - Remove and clean cartridge yearly or after every 25 hours, whichever occurs first. Service more often if necessary. Clean by tapping gently on flat surface. If very dirty, replace the cartridge using only original equipment parts available at any engine service center.

Do not use petroleum solvents, such as kerosene, to attempt to clean the cartridge. They may cause deterioration of the cartridge. **DO NOT OIL CARTRIDGE. DO NOT USE PRESSURIZED AIR TO CLEAN OR DRY CARTRIDGE.**

4. **Spark Plug** - Clean and reset gap at .030" every 250 hours of operation. Do not blast clean spark plug. Clean by scraping or wire brushing and washing with a commercial solvent. Poor spark will occur if terminal does not fit firmly on spark plug. If this happens reform the terminal to fit firmly on spark plug tip.

## GENERATOR CARE

Proper care and maintenance of the generator is necessary to ensure a long trouble free life.

1. **Exercising The Generator** - The generator should be operated every three to four weeks. It should be operated for a period of time sufficient to warm the unit up and to dry out any moisture that has accumulated in the windings. If left, this moisture can cause corrosion in the winding. Frequent operation of the engine generator set will also insure that the set is operating properly should it be needed in an emergency.

2. **Generator Maintenance** - Any major generator service including the installation or replacement of parts should be performed only by a qualified electrical service technician. **USE ONLY FACTORY APPROVED REPAIR PARTS.**

- a. Bearing - The bearing used in these generators is a heavy duty double sealed ball bearing. They require no maintenance or lubrication.
- b. Receptacles - Quality receptacles have been utilized. If a receptacle should become cracked or otherwise damaged, replace it. Using damaged or cracked receptacles can be both dangerous to the operator and destructive to the equipment.

## CLEANING

Remove dirt and debris with a cloth or brush. **DO NOT** use high pressure spray to clean either the engine or the generator. This high pressure spray could contaminate the fuel system and the generator components.

1. Keep the air inlet screen on both the engine and generator free of any dirt or debris to insure proper cooling. At least yearly remove the blower housing on the engine and clean the chaff and dirt out of the engine cooling fins and flywheel. Clean more often if necessary. Failure to keep these areas clean may cause overheating and permanent damage to the unit.

2. Periodically clean muffler area to remove all grass, dirt and combustible debris to prevent a fire.

3. On engine mufflers equipped with spark arresters, the spark arrester must be removed every 50 hours for cleaning and inspection. Replace if damaged.

## TROUBLESHOOTING HINTS

### PROBLEM (SYMPTOMS) POSSIBLE CAUSES

---

Won't Start	*Low Oil Level. *Fouled spark plug. *Out of fuel. *Off switch in Off position.
-------------	-----------------------------------------------------------------------------------------

---

Voltage too low	*Engine speed is too low. *Generator overloaded. *Defective stator. *Defective rotor (field).
-----------------	--------------------------------------------------------------------------------------------------------

---

Circuit Breaker Trips	*Defective load. *Defective receptacle.
--------------------------	--------------------------------------------

---

Voltage too high	*Engine speed is too high.
------------------	----------------------------

---

Generator over-heating	*Overloaded. *Insufficient ventilation.
---------------------------	--------------------------------------------

---

No output voltage	*Short in load (disconnect). *Broken or loose wire. *Defective receptacle. *No residual magnetism (in generator). *Defective stator. *Defective rotor (field). *Shorted capacitor. *GFCI Receptacle tripped.
-------------------	--------------------------------------------------------------------------------------------------------------------------------------------------------------------------------------------------------------------------------------

---



## 12 MONTH LIMITED WARRANTY

WINCO, Incorporated warrants to the original purchaser for 12 months\* or 1000 hours which ever occurs first, that goods manufactured or supplied by it will be free from defects in workmanship and material, provided such goods are installed, operated and maintained in accordance with WINCO written instructions.

\* NOTE: Units used for rental, demonstrations, commercial or prime power applications such as construction or utility, are warranted for 90 days. Units that are resold are not covered under this warranty. Any further warranty, whether expressed or implied, rests solely with the reseller.

WINCO's sole liability, and Purchaser's sole remedy for a failure under this warranty, shall be limited to the repair of the product. At WINCO's option, material found to be defective in material or workmanship under normal use and service will be repaired or replaced. For warranty service, return the product within 12 months or 1000 hours which ever occurs first from the date of purchase, transportation charges prepaid, to your nearest WINCO Authorized Service Center or to WINCO, Inc. at LeCenter Minnesota.

THERE IS NO OTHER EXPRESS WARRANTY.

To the extent permitted by law, any and all warranties, including those of merchantability and fitness for a particular purpose, are limited to 12 months or 1000 hours which ever occurs first, from date of purchase. In no event is WINCO liable for incidental or consequential damages.

Note: Some states do not allow limitation on the duration of implied warranty and some states do not allow the exclusion or limitation of incidental or consequential damages, so the above limitations may not apply in every instance. This warranty gives you specific legal rights which may vary from state to state.

WINCO reserves the right to change or improve its products without incurring any obligations to make such changes or improvements on products purchased previously.

### EXCLUSIONS:

WINCO does not warrant Engines. Engines are covered exclusively by the warranties of their respective manufacturers, see enclosed warranties.

WINCO does not warrant Batteries, or Other Component Parts that are warranted by their respective manufacturers.

WINCO does not warrant modifications or alterations which were not made by WINCO Inc.

WINCO does not warrant products which have been subjected to misuse and/or negligence or have been involved in an accident.



# WIRING DIAGRAM

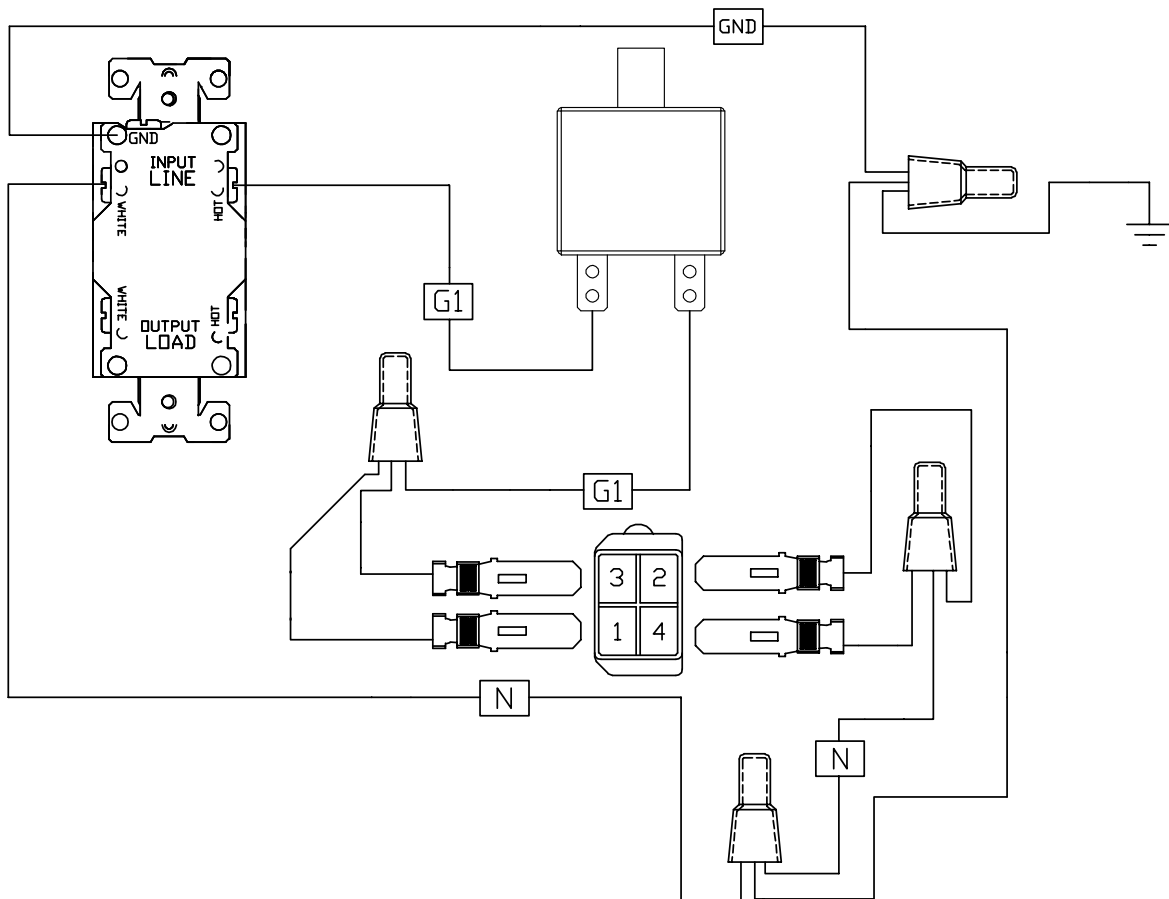

**WINGO INC**  
A Division of **DTI** Dyna Technology Inc

225 S. CORDOVA AVE.  
LECENTER, MN 56057  
507-357-6821  
SERVICE DEPT.  
507-357-6831