



# ILLUSTRATED PARTS LIST

**PSS50LS/C**  
**PSS50LS/D**  
**PSS50LS/E**

**2003-2007**  
**WITH BASLER**  
**DGC-500 ENGINE**  
**CONTROL**



225 S. CORDOVA AVE.  
LECENTER, MN 56057  
507-357-6821  
SERVICE DEPT.  
507-357-6831

# GENERATOR ASSEMBLY

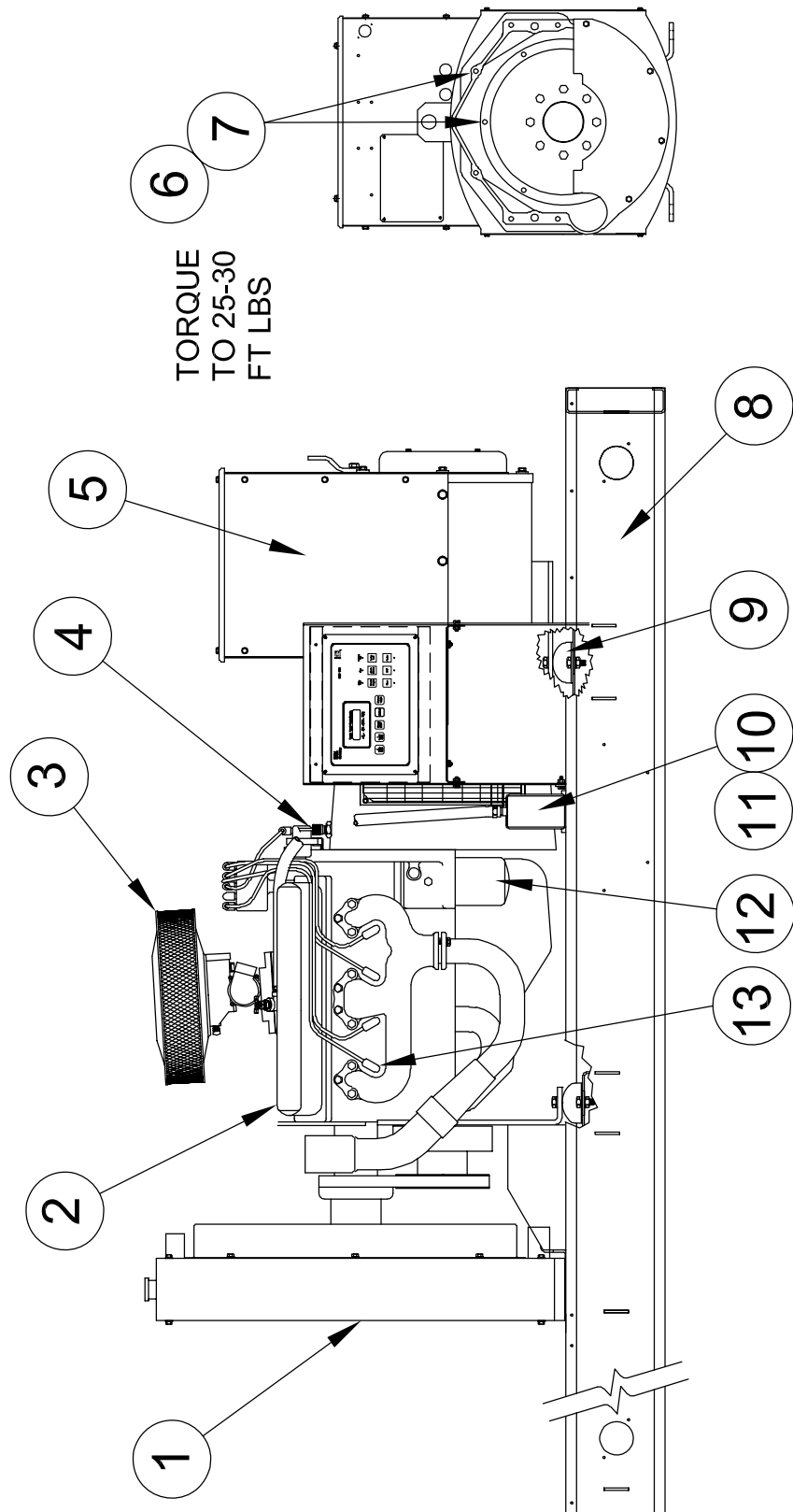

REF #	PART NUMBER	QTY	DESCRIPTION
1	Reference	1	Radiator
2	SEE TABLE	1	Engine, GM 5.7 Liter
3	F1-9	1*	Air Filter
4	350101-1	1	Magnetic Pick-up
5	SEE TABLE	1	Generator
6	96000-004	12	3/8"-16 X 1 1/2" Bolt
7	481-001	12	3/8" Split Lock Washer
8	99381-012	1	Base Assembly
9	98956-001	4	Shockmount
10	350087-2	1	Heater 1000W 120V
11	93689-001	6.9 FT	5/8" I.D. Heater Hose
12	PF1218	1**	Oil Filter
13	41-932	8**	Spark Plug
NI	350818	1	SX 460 Voltage Regulator
NI	Not Illustrated		
*	IMPCO Part #		
**	AC Delco Part #		

MODEL #	PART #
PSS50LS/CNG PSS50LS/DNG PSS50LS/ENG	350775-7
PSS50LS/CLPG PSS50LS/DLPG PSS50LS/ELPG	350775-9
PSS50LS/CLP PSS50LS/DLP PSS50LS/ELP	350775-8

MODEL #	STAMFORD NEWAGE GENERATOR MODEL #	WINCO PART #
PSS50LS-3/C PSS50LS-3/D PSS50LS-3/E	UCI224D 4-LEAD	350685-21
PSS50LS-4/C, D, E PSS50LS-17/C, D, E PSS50LS-18/C, D, E	UCI224D 12-LEAD	350685-2

# CIRCUIT BREAKER ASSEMBLY PSS50LS-3/C & /D

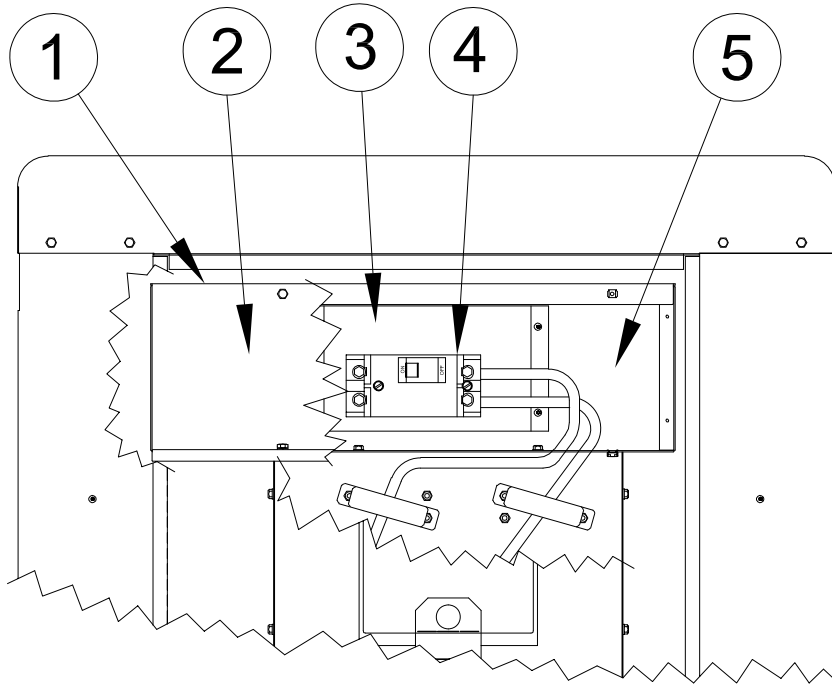

# CIRCUIT BREAKER ASSEMBLY PSS50LS-4/C & /D, PSS50LS-17/C & /D PSS50LS-18/C & /D

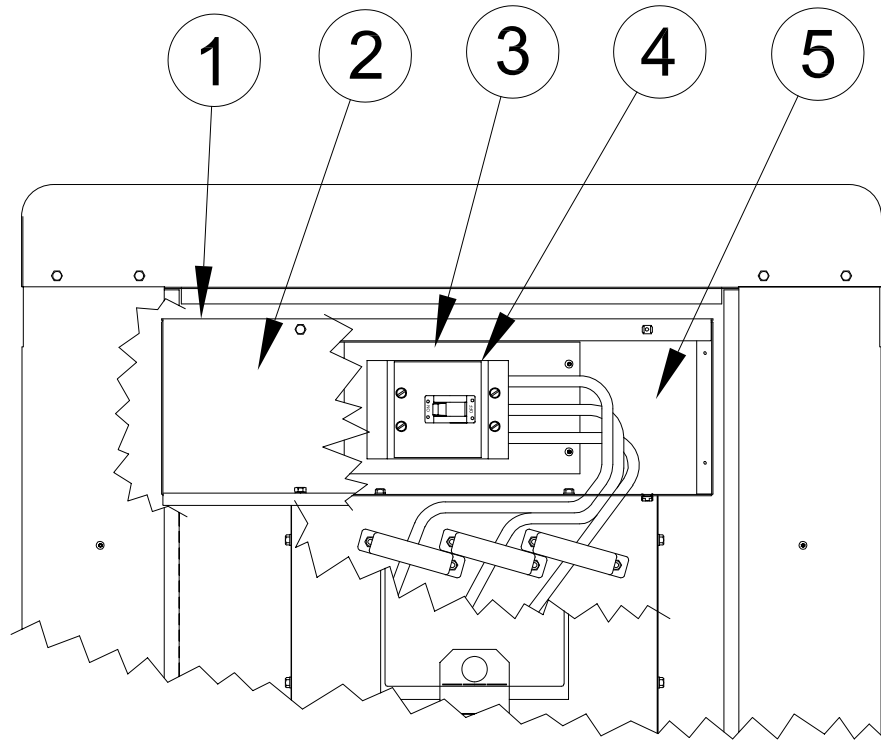

REF #	PART NUMBER	QTY	DESCRIPTION
1	99782-000	1	CB Box Back & Top Panel
2	99782-004	1	CB Box Front Panel
3	SEE TABLE	1	Mounting Panel
4	SEE TABLE	1	Circuit Breaker
5	99782-001	1	CB Box Bottom & Side Panel

MODEL #	PART #	DESCRIPTION
PSS50LS-3/C & /D PSS50LS-4/C & /D	99782-007	Mounting Panel
PSS50LS-17/C & /D PSS50LS-18/C & /D	99782-005	Mounting Panel

MODEL #	PART #	DESCRIPTION
PSS50LS-3/C & /D	91447-005	200 Amp 2-Pole Breaker
PSS50LS-4/C & /D	81096-004	175 Amp 3-Pole Breaker
PSS50LS-17/C & /D	81096-003	150 Amp 3-Pole Breaker
PSS50LS-18/C & /D	81097-006	80 Amp 3-Pole Breaker

# CIRCUIT BREAKER ASSEMBLY PSS50LS/E

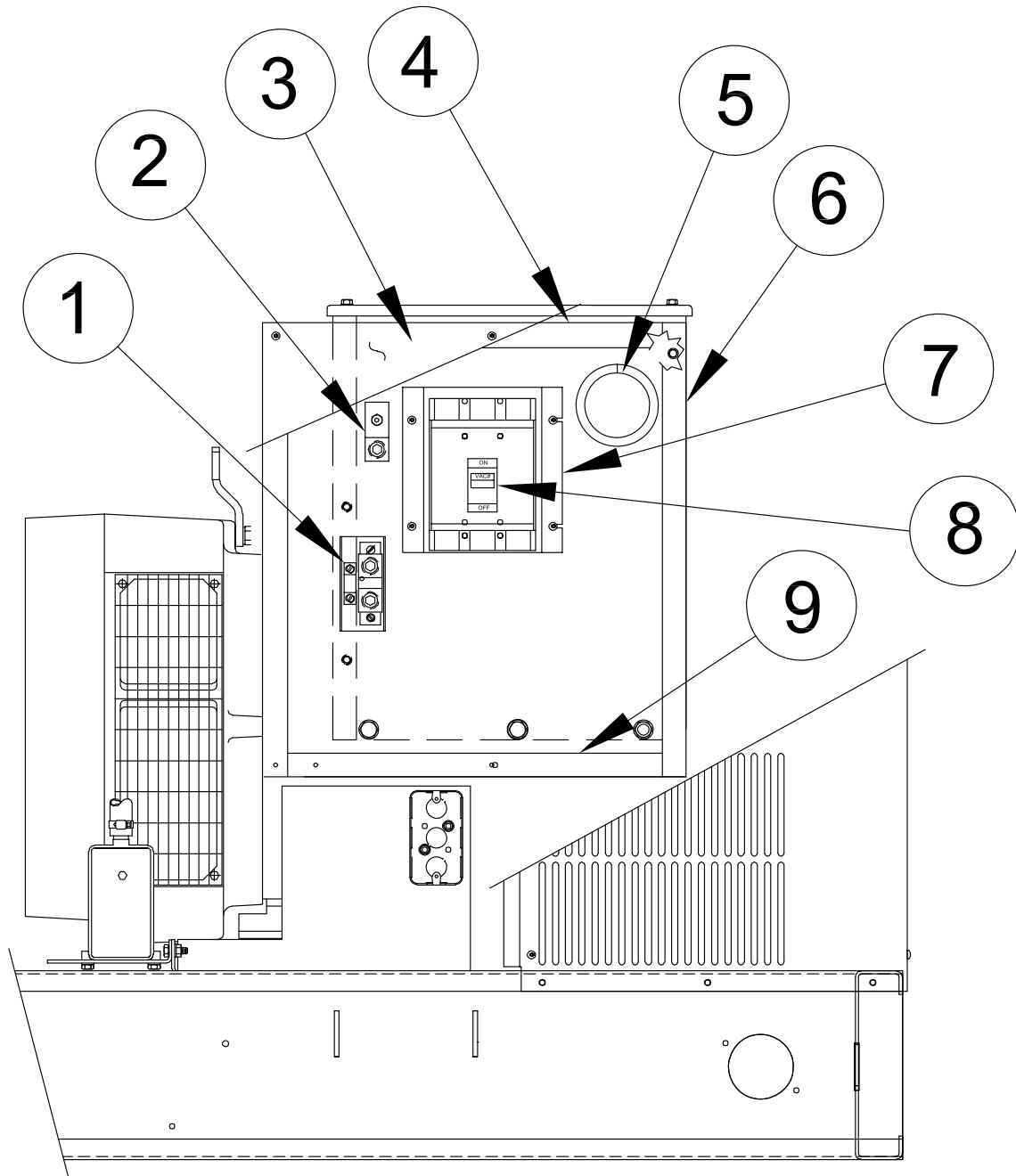

REF #	PART NUMBER	QTY	DESCRIPTION
1	350124-4	1	Neutral Terminal
2	58060-000	1	Ground Terminal
3	99827-004	1	Cabinet Cover Plate
4	99828-003	1	Cabinet Top Panel
5	58684-000	.72 FT	Edge Trim
6	99826-001	1	Cabinet Back & Side Panel
7	99831-003	1	Circuit Breaker Spacer
8	SEE TABLE	1	Circuit Breaker
9	99828-002	1	Cabinet Bottom Panel

MODEL #	PART #	DESCRIPTION
PSS50LS-3/E	91447-005	200 Amp 2-Pole Breaker
PSS50LS-4/E	81096-004	175 Amp 3-Pole Breaker
PSS50LS-17/E	81096-003	150 Amp 3-Pole Breaker
PSS50LS-18/E	81097-006	80 Amp 3-Pole Breaker

# ENGINE CONTROL ASSEMBLY

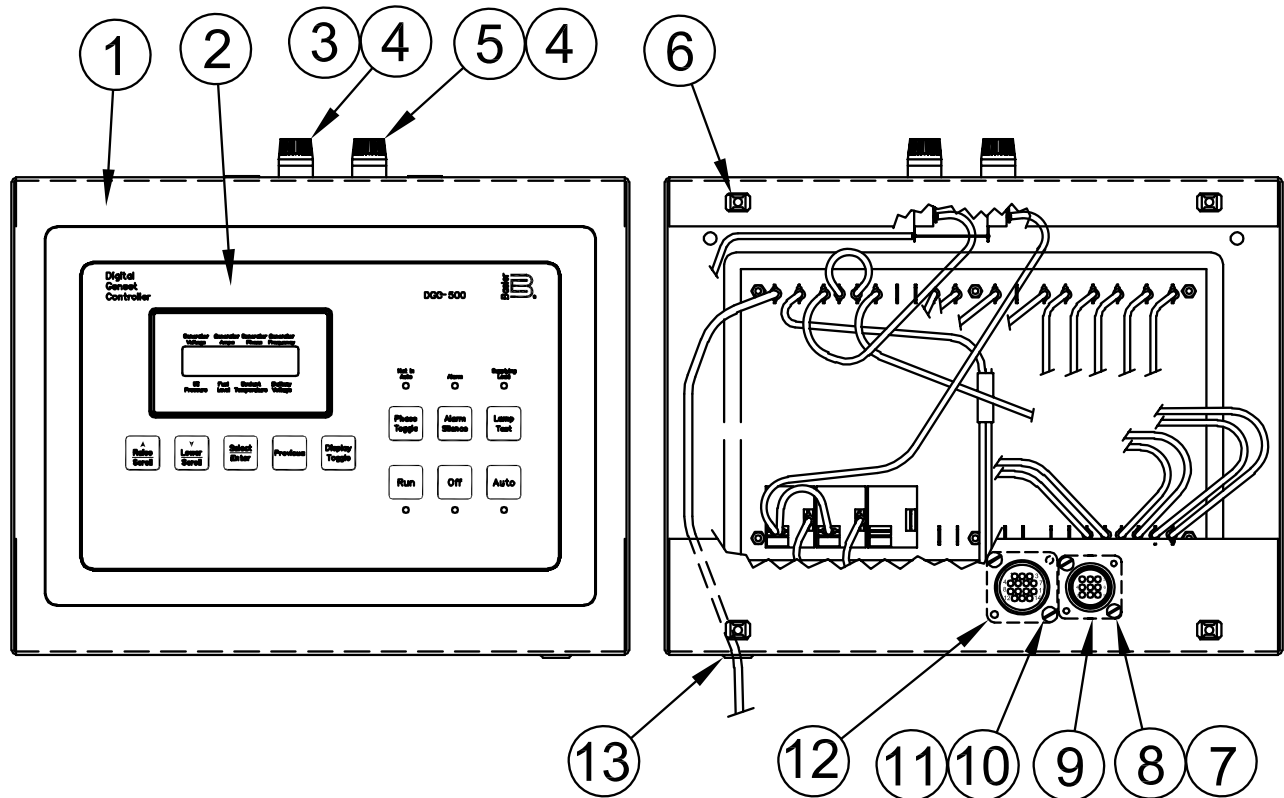

REF #	PART NUMBER	QTY	DESCRIPTION
1	99055-003	1	Control Box Panel
2	351147-2	1	Basler DGC-500 Control
3	95064-006	1	10 Amp Fuse
4	2489-001	2	Fuse Holder
5	95064-003	1	1 Amp Fuse
6	92495-000	4	¼-20 Retainer Nut
7	97322-000	2	#4-40 X ½" Screw
8	97327-000	2	#4-40 Elastic Stop-nut
9	96925-005	1	9 Pin Connector
10	24988-000	2	#6-32 X ½" Screw
11	51802-000	2	#6-32 Elastic Stop-nut
12	96925-002	1	14 Pin Connector
13	45853-000	1	Grommet
NI	15983-003	1	1 Amp Fuse Decal
NI	15983-004	1	10 Amp Fuse Decal
NI	Not Illustrated		

# ELECTRICAL SYSTEM ASSEMBLY

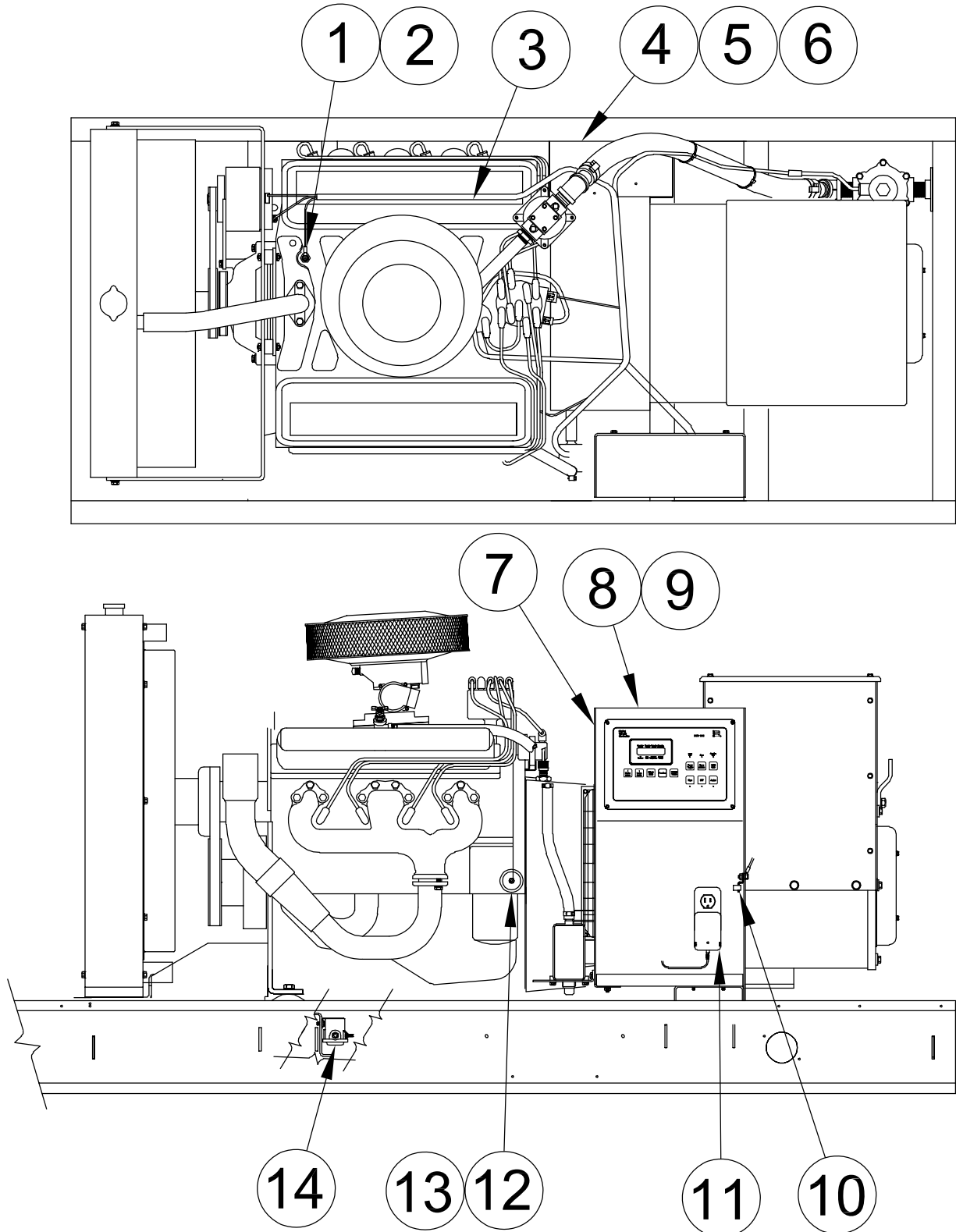

REF #	PART NUMBER	QTY	DESCRIPTION
1	99265-001	1	Temperature Sender
2	56372-000	1	3/8" to 1/2" Reducer
3	SEE TABLE	1	Engine Control Harness
4	99317-001	1	Battery Tray
5	53220-058	1	Positive (+) Battery Cable
6	53220-013	1	Negative (-) Battery Cable
7	44058-014	1	Hole Plug
8	99057-008	1	Support Pedestal
9	99055-004	1	Access Plate
10	48042-000	1	Ground Lug
11	Reference	1	Battery Charger Assembly
12	99267-001	1	Oil Pressure Sender
13	80951-000	1	1/8" to 1/4" Reducer
14	80980-000	1	Start Control Solenoid

MODEL	PART NUMBER
PSS50LS/C	99420-008
PSS50LS/D PSS50LS/E	99420-010

# AC WIRING ASSEMBLY PSS50LS-3/C,D,E

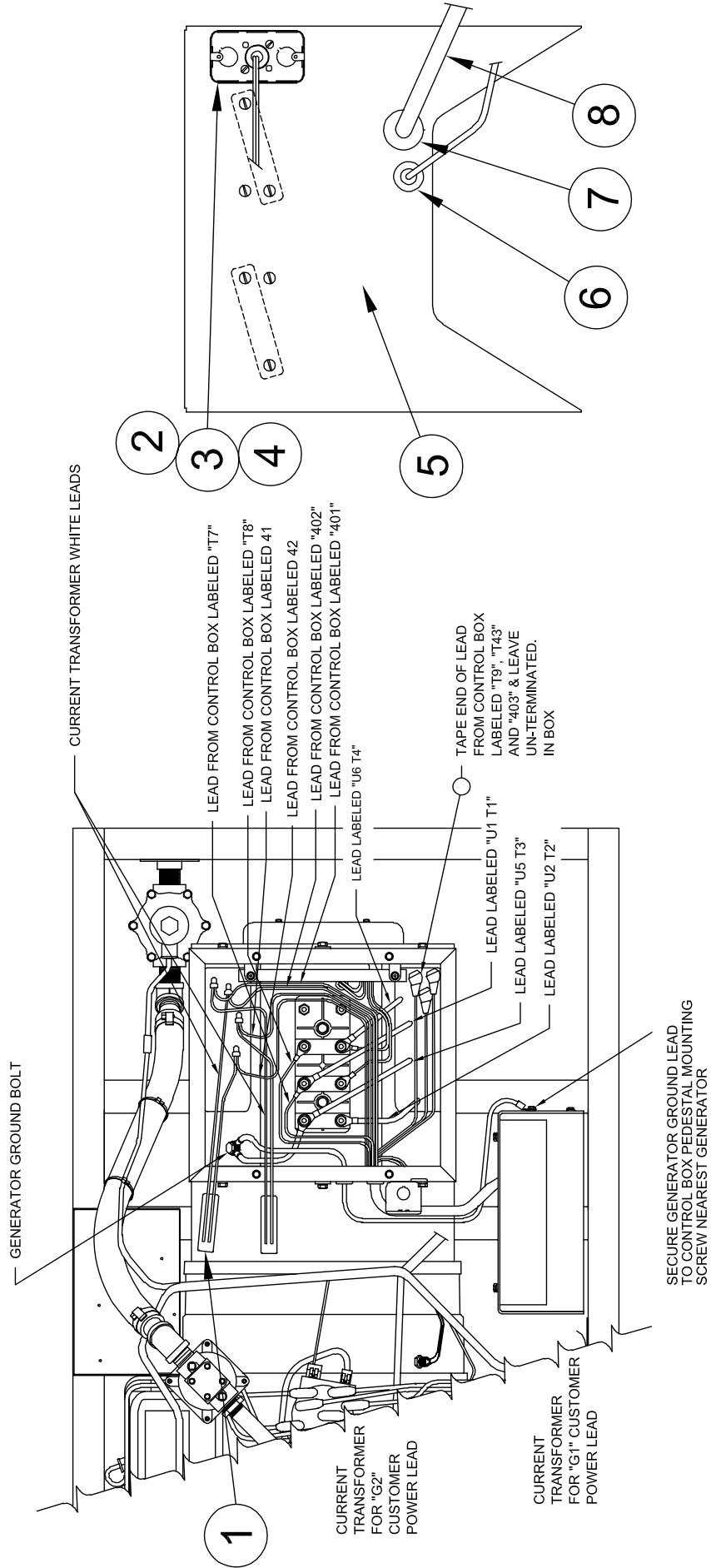

REF #	PART NUMBER	QTY	DESCRIPTION
1	SEE TABLE	2 or 3	Current Transformers
2	92789-000	1	Conduit Box
3	59026-000	1	Conduit Box Cover
4	40730-000	1	Grommet
5	SEE TABLE	1	Rear Panel
6	23917-000	1	Grommet
7	62486-000	1	Grommet
8	99347-008	1	AC Harness Assembly

MODEL #	PART #	QTY	DESCRIPTION
PSS50LS-3/C PSS50LS-3/D PSS50LS-3-E	80124-006	2	300 to 5 Amp Current Transformer
PSS50LS-4/C PSS50LS-4/D PSS50LS-4/E PSS50LS-17/C PSS50LS-17/D PSS50LS-17/E	80124-005	3	300 to 5 Amp Current Transformer
PSS50LS-18/C PSS50LS-18/D PSS50LS-18/E	81024-003	3	100 to 5 Amp Current Transformer

MODEL #	PART #	QTY	DESCRIPTION
PSS50LS/C PSS50LS/D	350028-13	1	Rear Panel
PSS50LS/E	350028-36	1	Rear Panel

# AC WIRING ASSEMBLY PSS50LS-4/C,D,E

CURRENT TRANSFORMERS MOUNTING LOCATIONS, IF THEY HAVE MOUNTING FEET MOUNT THEM WITH THIS HARDWARE TO BACKPANEL OF GENERATOR BOX. IF NOT USE HARDWARE TO PLUG HOLES.

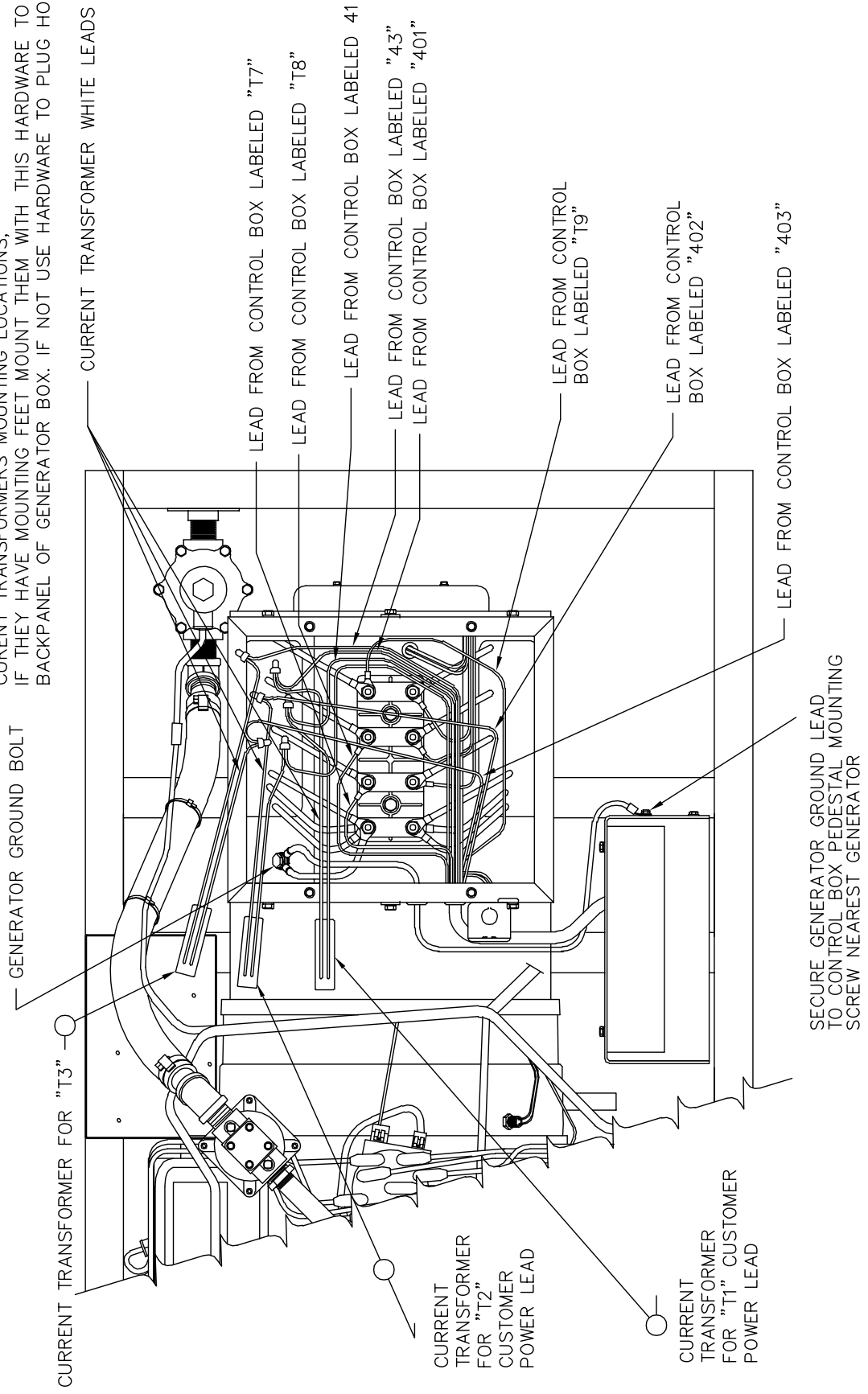

# AC WIRING ASSEMBLY PSS50LS-17/C,D,E

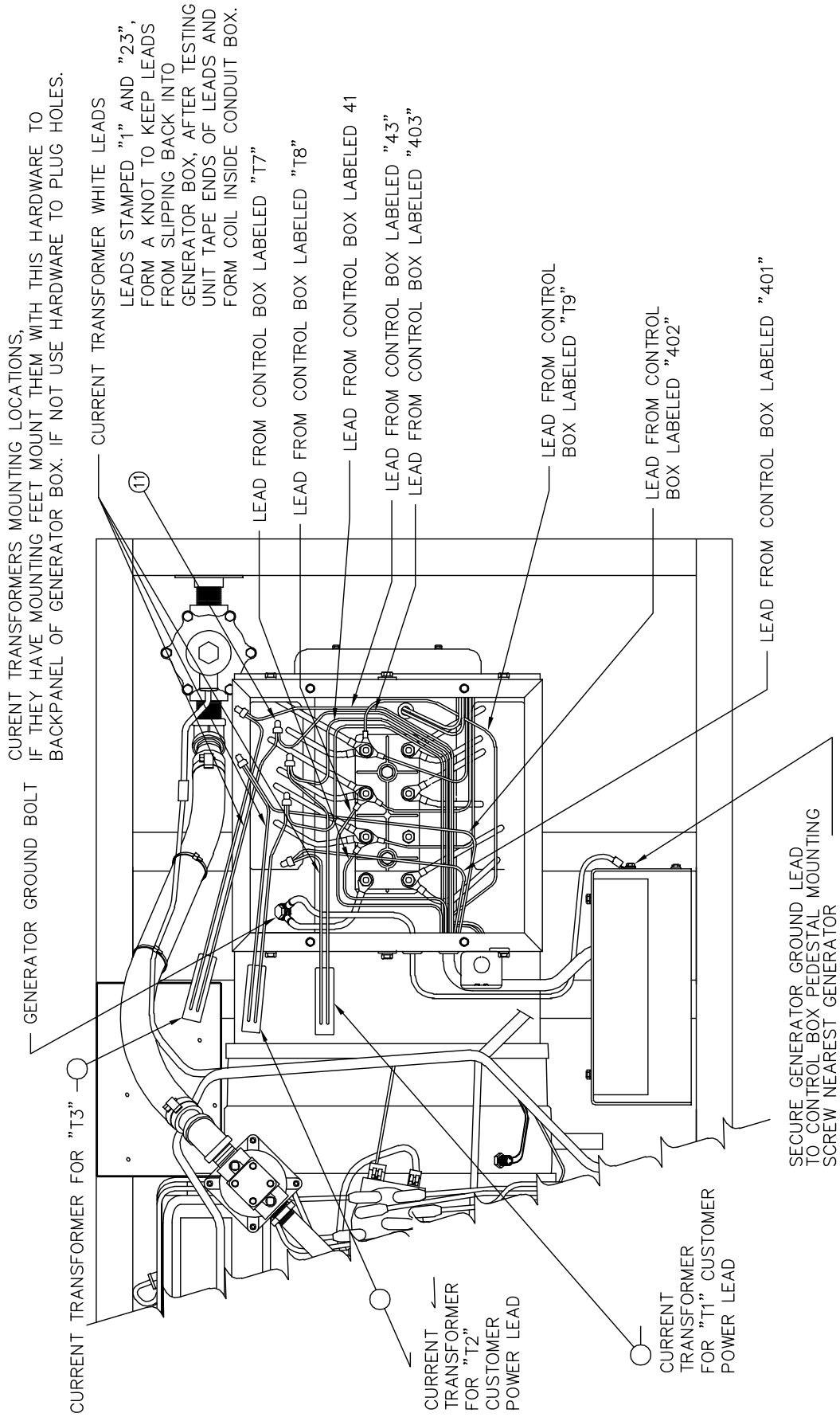

# AC WIRING ASSEMBLY PSS50LS-18/C,D,E

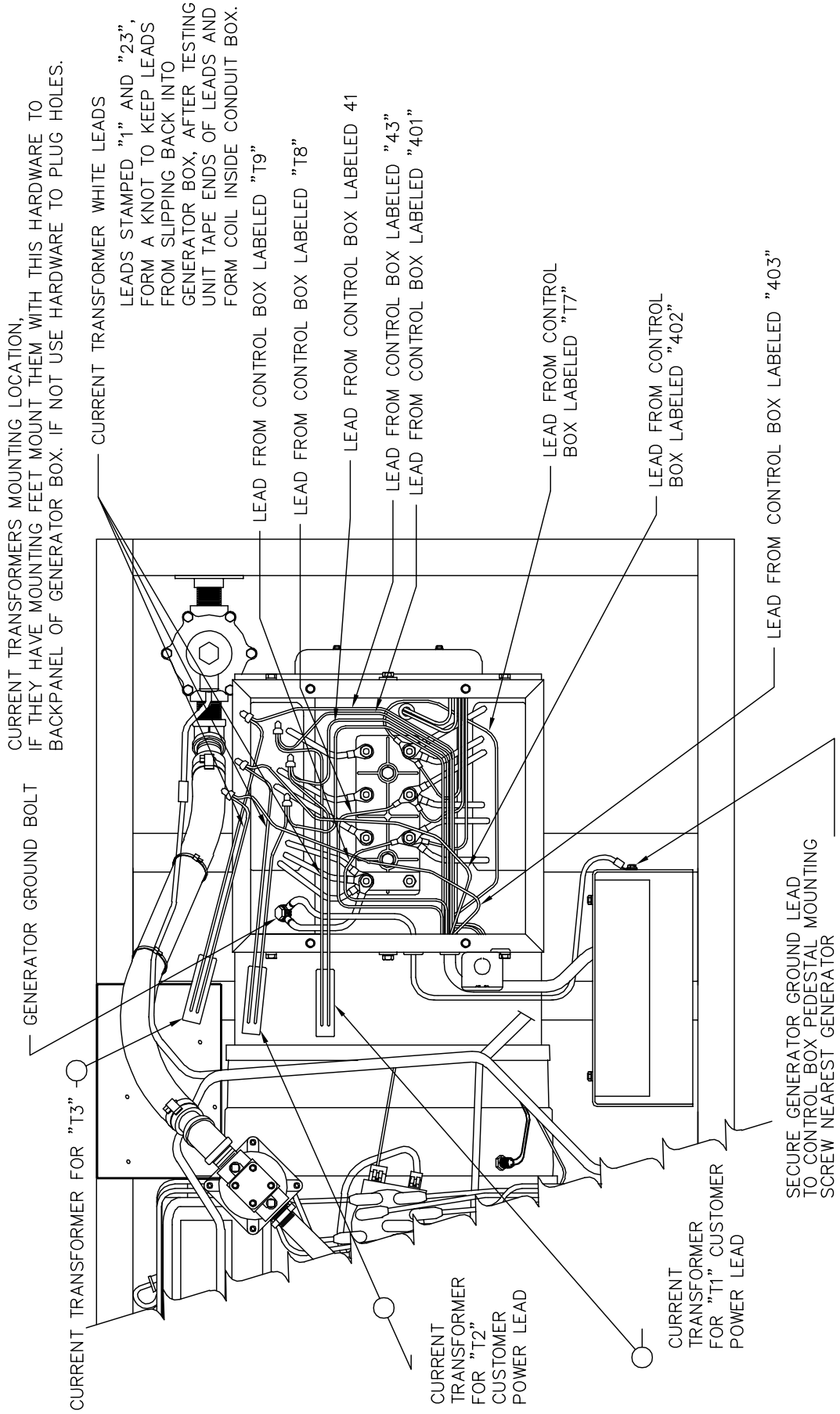

# VAPOR FUEL SYSTEM ASSEMBLY

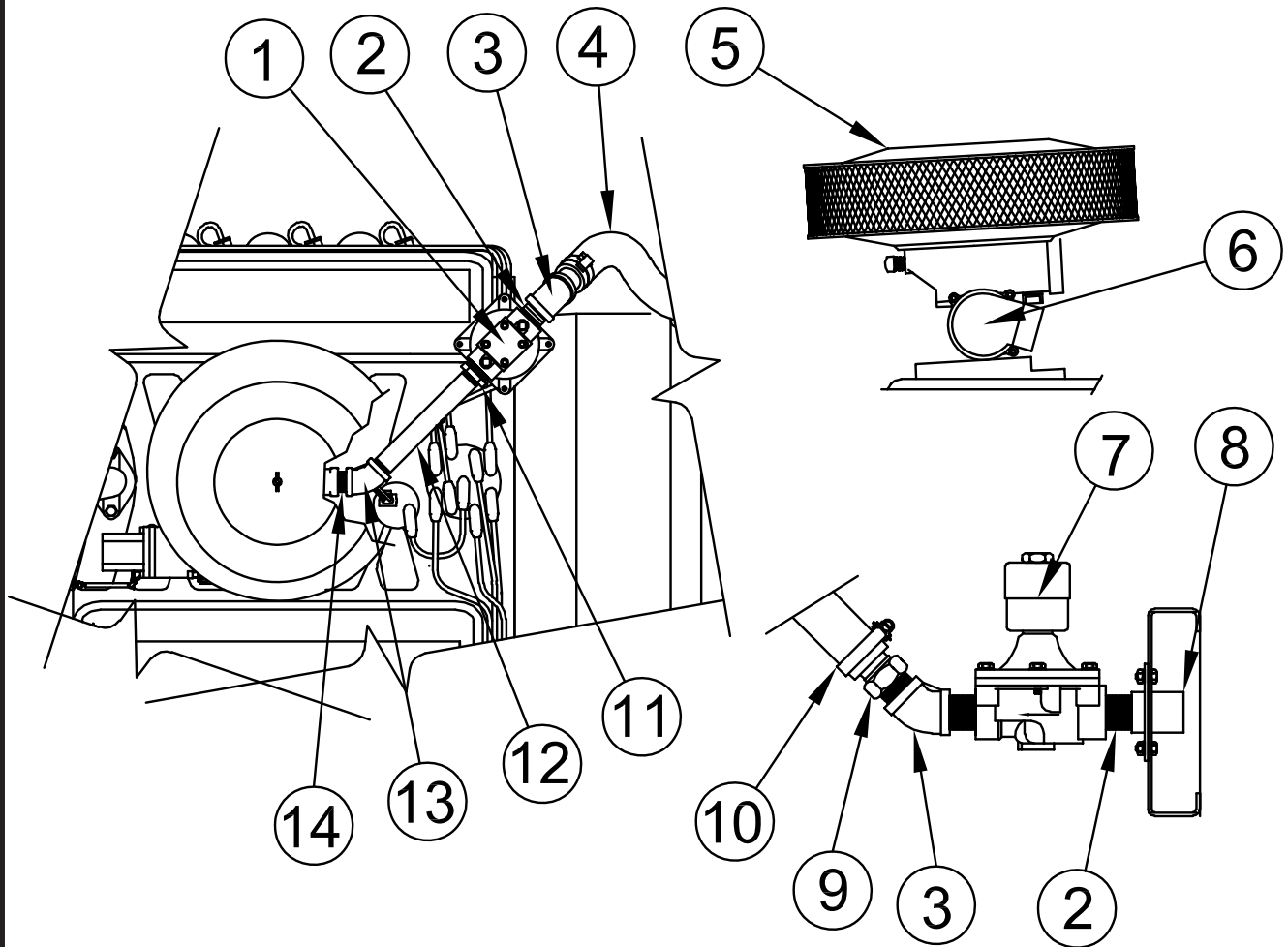

REF #	PART NUMBER	QTY	DESCRIPTION
1	81017-000	1	Regulator
2	81079-000	3	1" Pipe Nipple
3	23996-000	2	1" X 45° Pipe Elbow
4	81103-000	4 FT	1-1/4" I.D. Hose
5	F1-9	1*	Air Filter
6	38900362	1**	"L" Series Governor
7	42942-001	1	Solenoid
8	99065-000	1	Fuel Inlet Weldment
9	92388-006	2	Hose Fitting
10	81018-001	2	Hose Clamp
11	81077-000	1	3/4" to 1" Reducer
12	54074-007	1	3/4" X 8" Pipe Nipple
13	56896-000	1	3/4" X 45° Pipe Elbow
14	22626-000	1	3/4" Pipe Nipple

\* Impco Part #

\*\* PSI Part Number

PSI (Power Solutions Inc.) Phone: (630)-350-9400

# LP LIQUID WITHDRAWAL ASSEMBLY

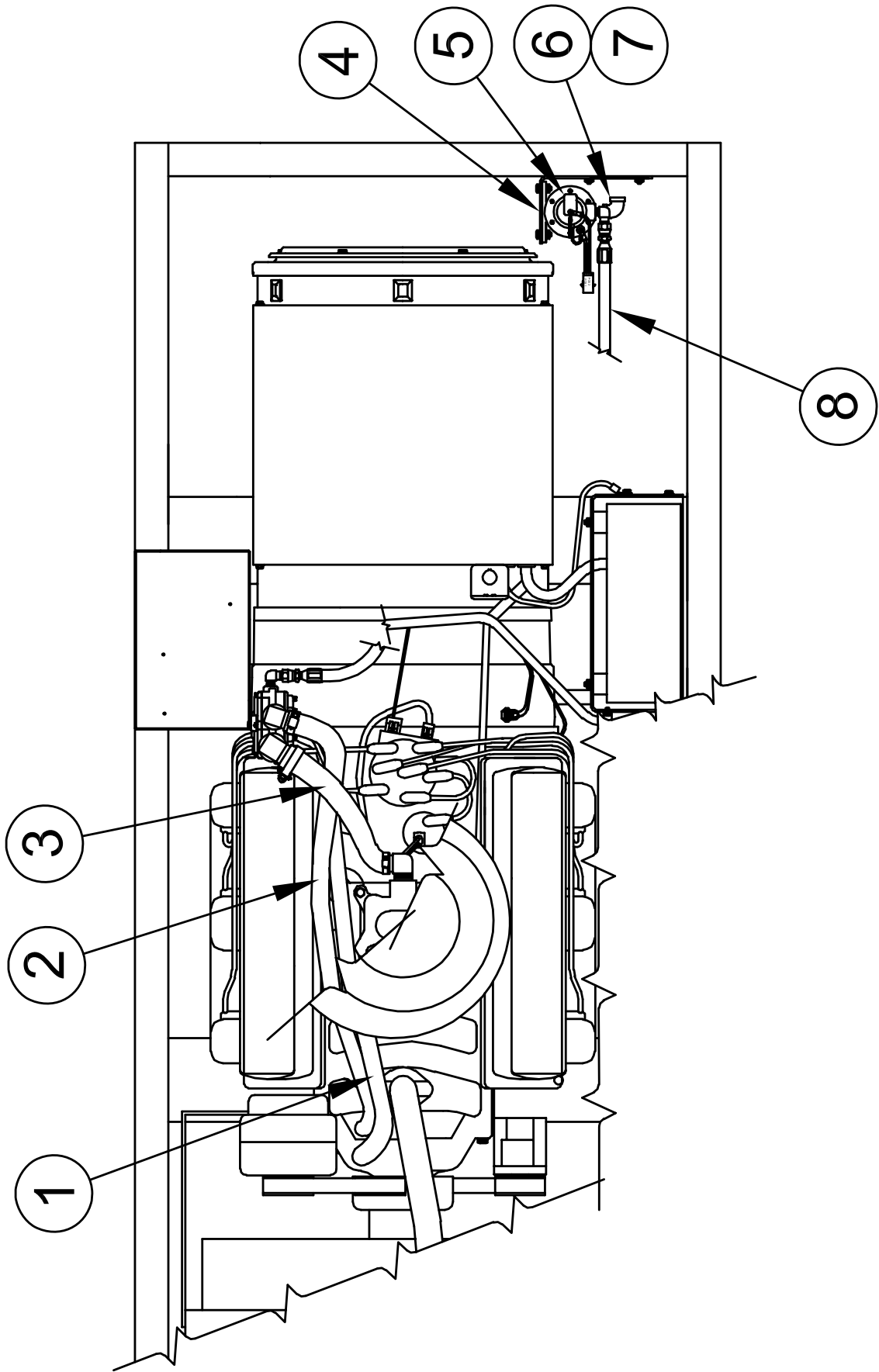

# LP LIQUID WITHDRAWAL ASSEMBLY

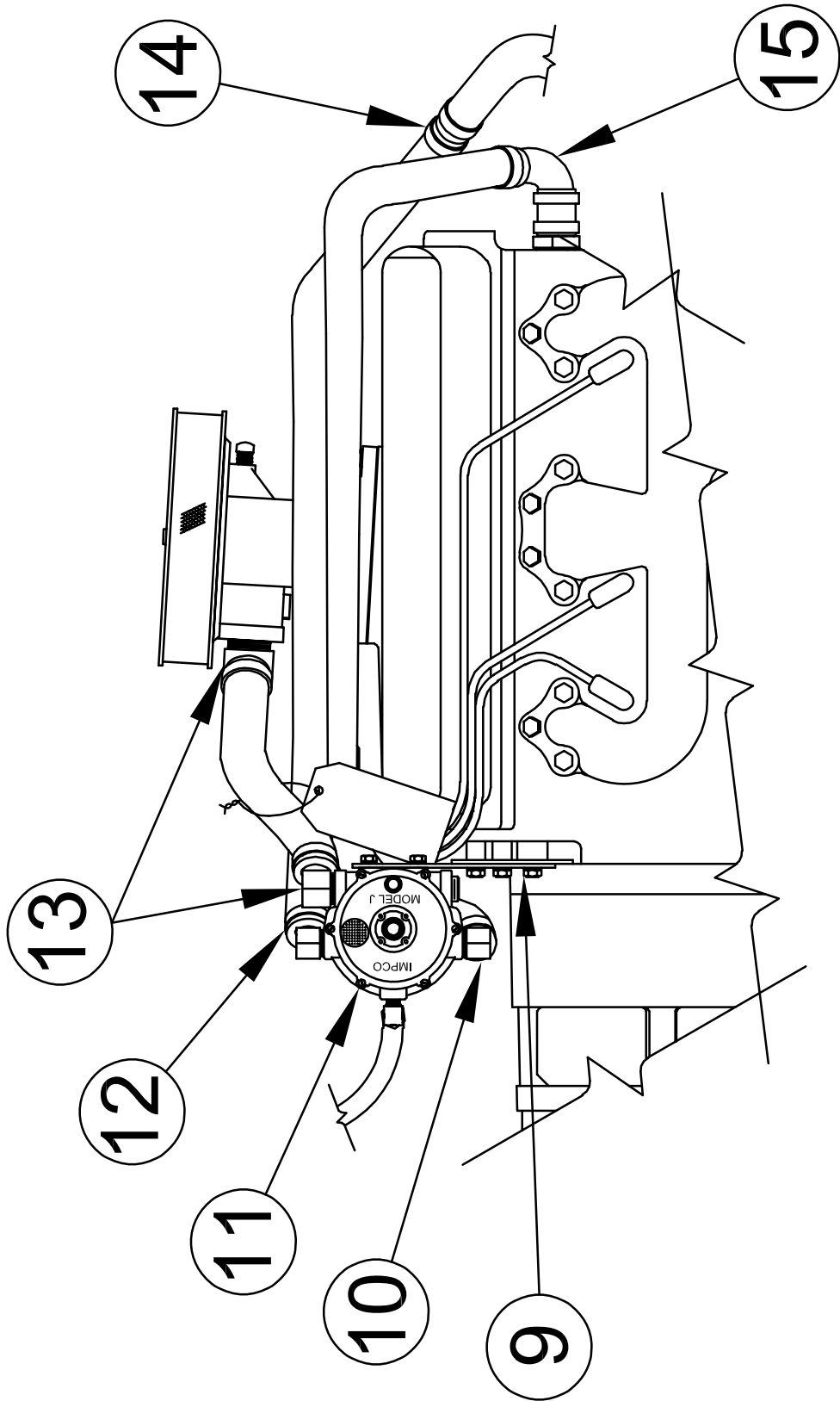

REF #	PART NUMBER	QTY	DESCRIPTION
1	93689-001	23"	5/8" Hose
2	93689-001	23"	5/8" Hose
3	93689-001	11"	5/8" Hose
4	99085-001	1	Fuel Cover Plate
5	99475-000	1	Solenoid
6	92533-000	1	1/4" 90° Elbow
7	81375-003	1	1/4" X 1 1/2" Pipe Nipple
8	92940-007	1	Hose Assembly
9	350217	1	Converter Mounting Bracket
10	92382-000	2	3/8" X 5/8" 90° Elbow
11	81636-000	1	Converter-Regulator
12	81018-005	8	Hose Clamp
13	92382-001	2	1/2" X 5/8" 90° Elbow
14	62274-001	1	5/8" Hose Coupler
15	62274-002	1	5/8" 90° Hose Coupler

## BATTERY TENDER ASSEMBLY

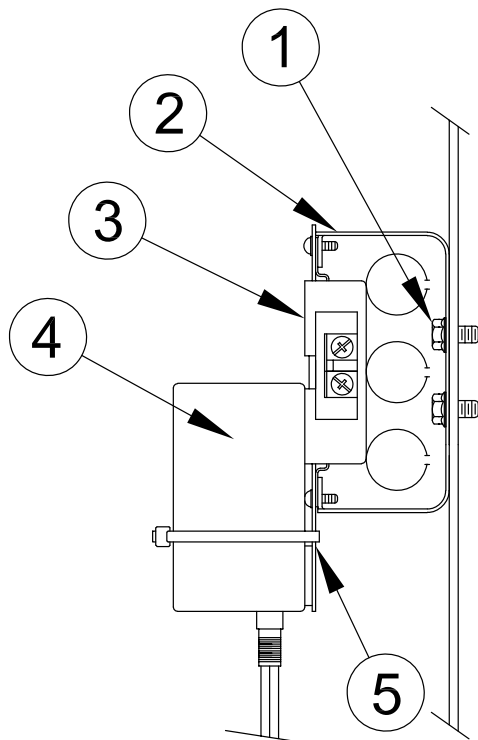

REF #	PART NUMBER	QTY	DESCRIPTION
1	52644-000	2	Self-tapping Screw
2	92789-000	1	Conduit Box
3	24749-000	1	Duplex Receptacle
4	16287-000	1	Battery Tender
5	59026-001	1	Recpt. Cover Plate

# EXHAUST ASSEMBLY

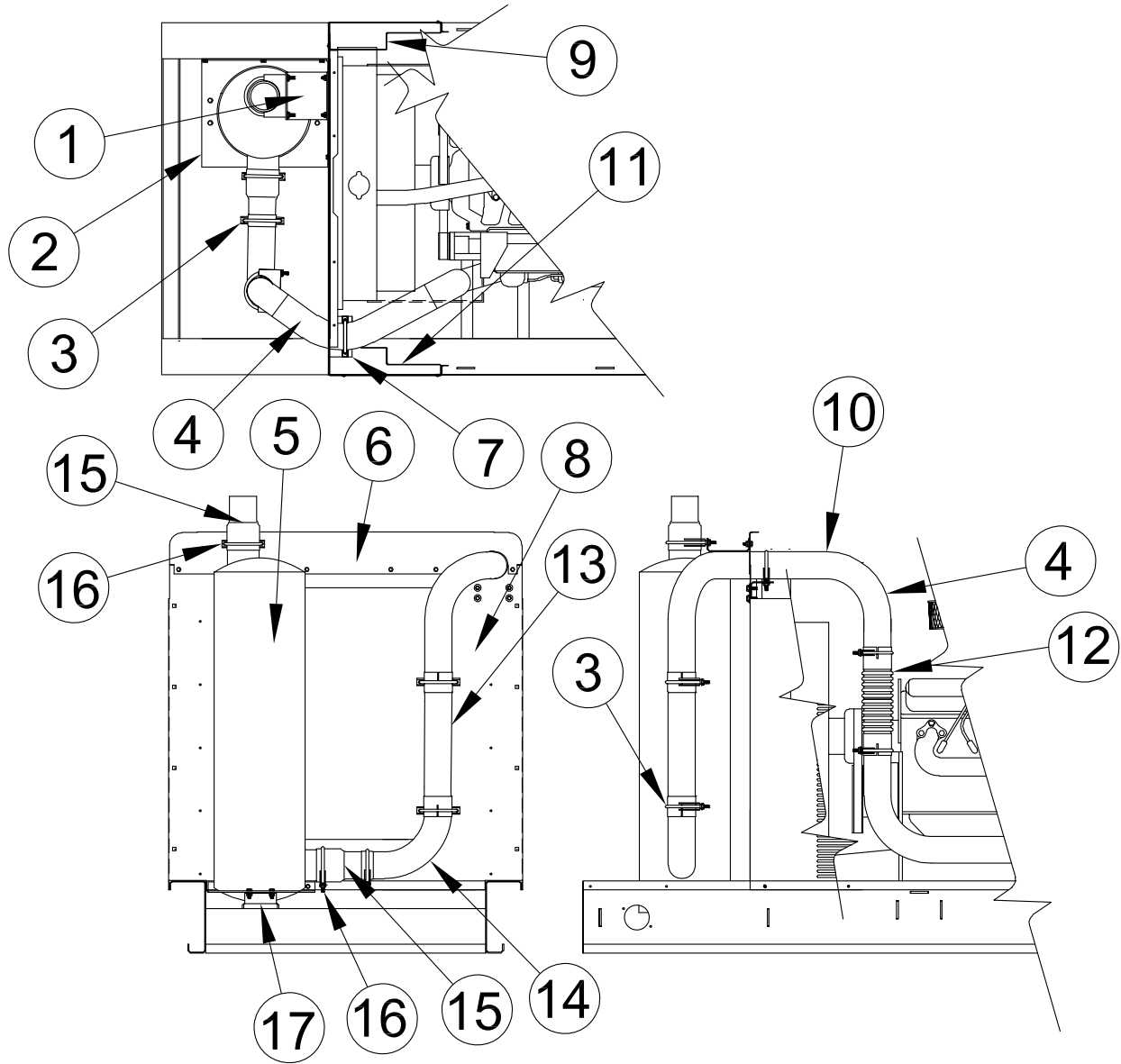

REF #	PART NUMBER	QTY	DESCRIPTION
1	99336-001	1	Top Muffler Support
2	99336-002	1	Muffler Support Tray
3	93489-001	6	3" Muffler Clamp
4	99677-000	1	Formed Exhaust Pipe
5	97409-002	1	Muffler
6	99334-002	1	Top Housing Front
7	99335-003	1	Muffler Support
8	99324-002	1	Housing Front
9	99378-003	1	Front Housing Baffle
10	97274-000	20 FT	High Temperature Silica Tape
11	99378-000	1	Front Housing Baffle
12	16016-004	1	Flex Exhaust
13	99677-001	1	3" Pipe Coupling
14	99502-003	1	3" 90° Elbow
15	97759-007	2	3.5" to 3" Reducer
16	93489-000	2	3.5" Muffler Clamp
17	99337-002	1	Muffler Support Bracket

## DECALS

REF #	PART NUMBER	QTY	DESCRIPTION
NI	15750-001	1	Ground Decal
NI	97813-000	3	Auto Start Warning
NI	15209-000	1	Warning Decal
NI	56596-000	1	Fuel Decal
NI	56597-000	1	Fuel Decal
NI	63941-001	1	Hot Surface Decal
NI	64891-001	1	Electrical Code Decal
NI	63941-003	1	Battery Warning Decal
NI	Not Illustrated		

# HOUSING ASSEMBLY

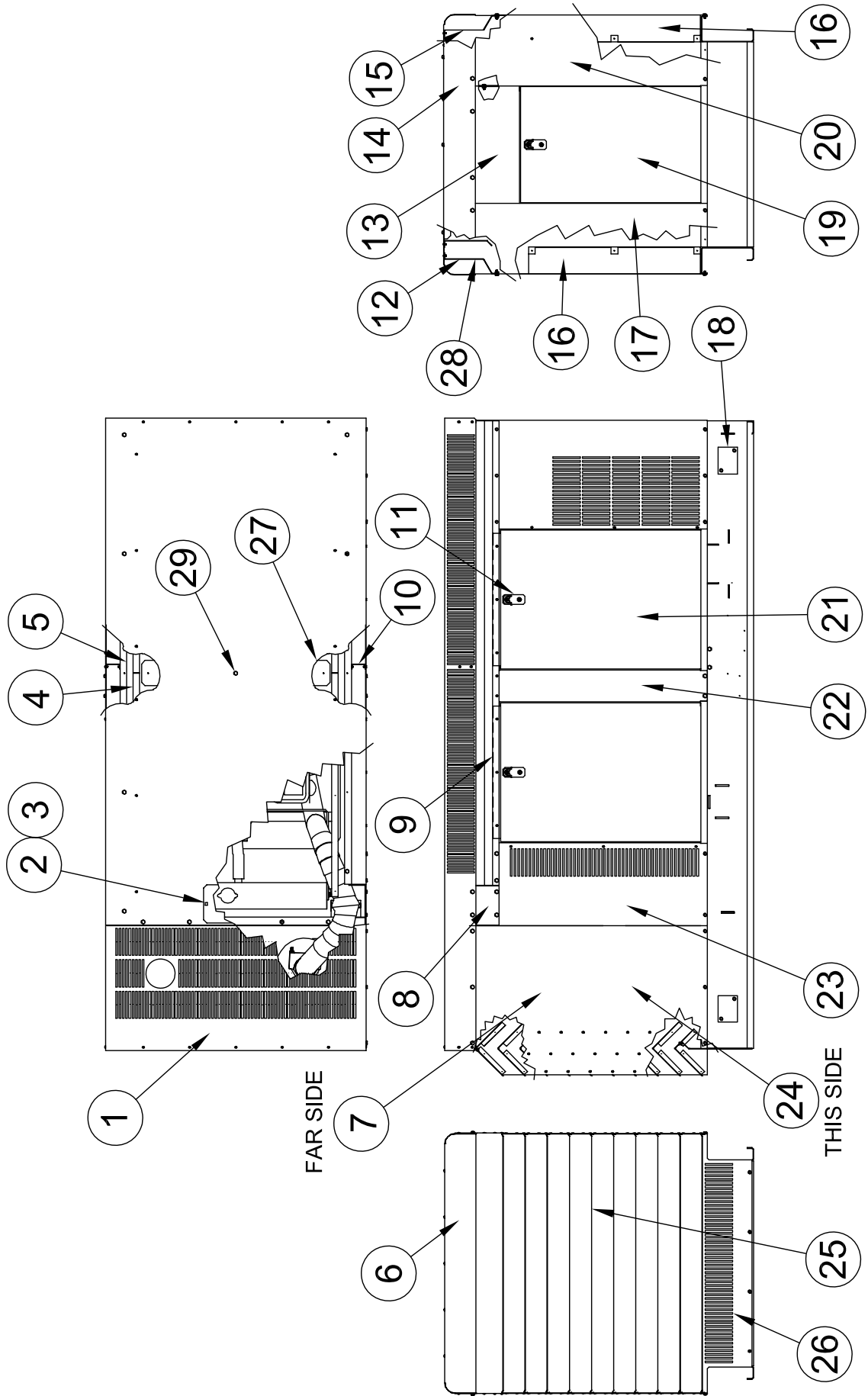

REF #	PART NUMBER	QTY	DESCRIPTION
1	99341-001	1	Roof
2	62912-000	33 FT	Neoprene Strip
3	62026-003	1	Radiator Cap Cover Plate
4	99327-004	1	Side Sill Baffle
5	99327-001	2	Side Sill Baffle
6	99368-001	1	Roof End Panel Front
7	99329-004	1	Right Extension Panel
8	99325-005	1	Side Sill Extension
9	99333-001	4	Door Jam
10	99339-000	2	Roof Brace
11	95229-004	5	Door Latch
12	99325-004	1	Left Side Sill
13	99326-001	1	Top Rear Sill
14	99368-002	1	Roof End Panel Rear
15	99325-009	1	Right Side Sill
16	99320-001	2	Corner Post Baffle
17	99319-002	1	Left Rear Corner Post
18	99060-000	1	Cover Plate
19	15680-018	1	Rear Door
20	99319-007	1	Right Rear Corner Post
21	15680-015	4	Side Door
22	99323-001	2	Mullion
23	99324-002	1	Housing Front
24	99329-005	1	Left Extension Panel
25	99631-001	8	Louver
26	99331-001	1	Front Extension Panel
27	99328-000	1	Roof Support
28	99327-002	1	Side Sill Baffle
29	62825-011	1	Spacer

# FOAM KIT

REF #	PART NUMBER	QTY	DESCRIPTION
1	99788-442	1	Side Sill Baffle Foam Part
2	99788-441	1	Side Sill Baffle Foam Part
3	99788-440	1	Roof Foam Part
4	99788-439	1	Rear Door Foam Part
5	99788-438	4	Side Door Foam Part
6	99788-437	2	Mullion Foam Part
7	99788-436	2	Rear Corner Post Foam Part
8	99788-413	1	Roof Foam Part
9	99788-403	2	Side Sill Baffle Foam Part
10	99788-402	1	Roof Foam Part

# PSS50LS-3/C,D,E

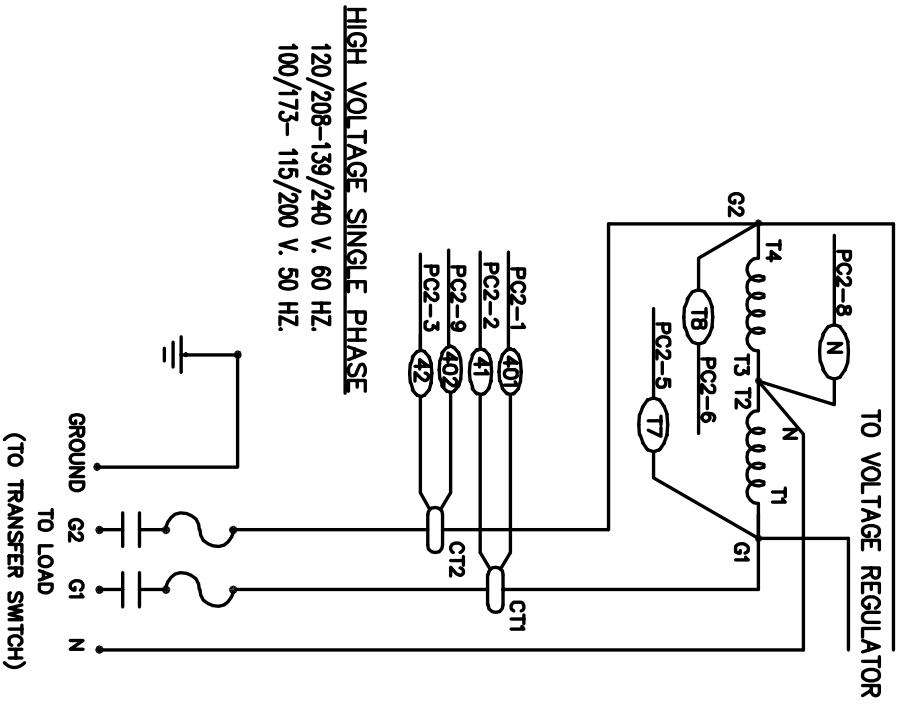

# PSS50LS-18/C,D,E

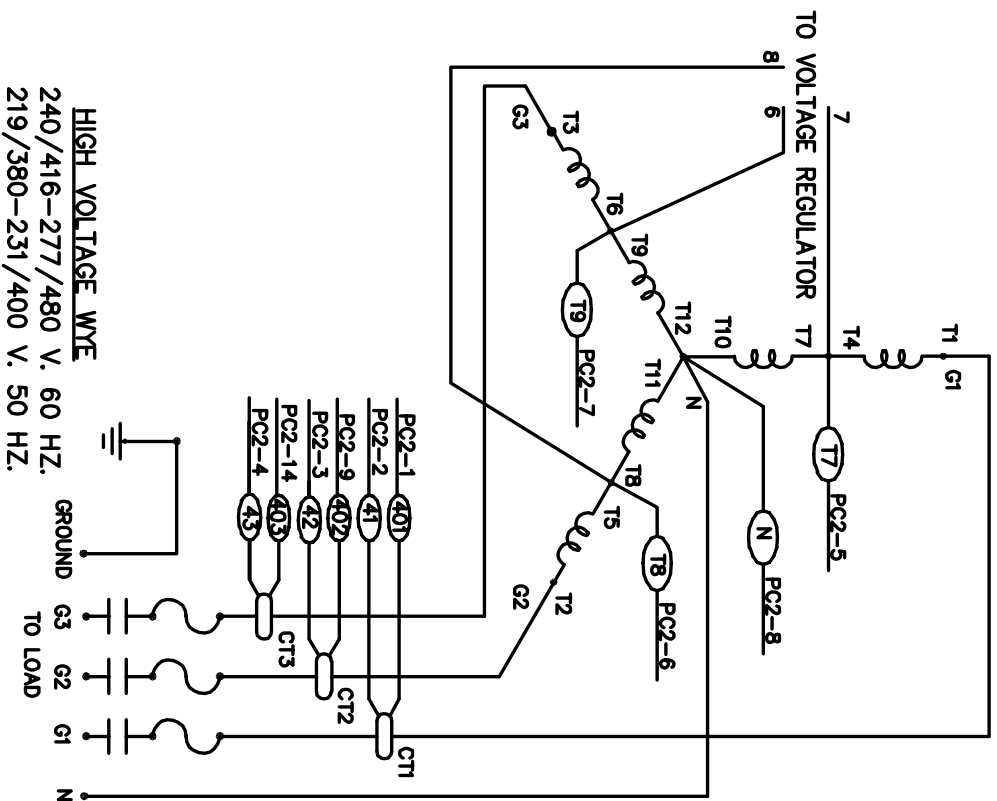

# PSS50LS-4/C,D,E

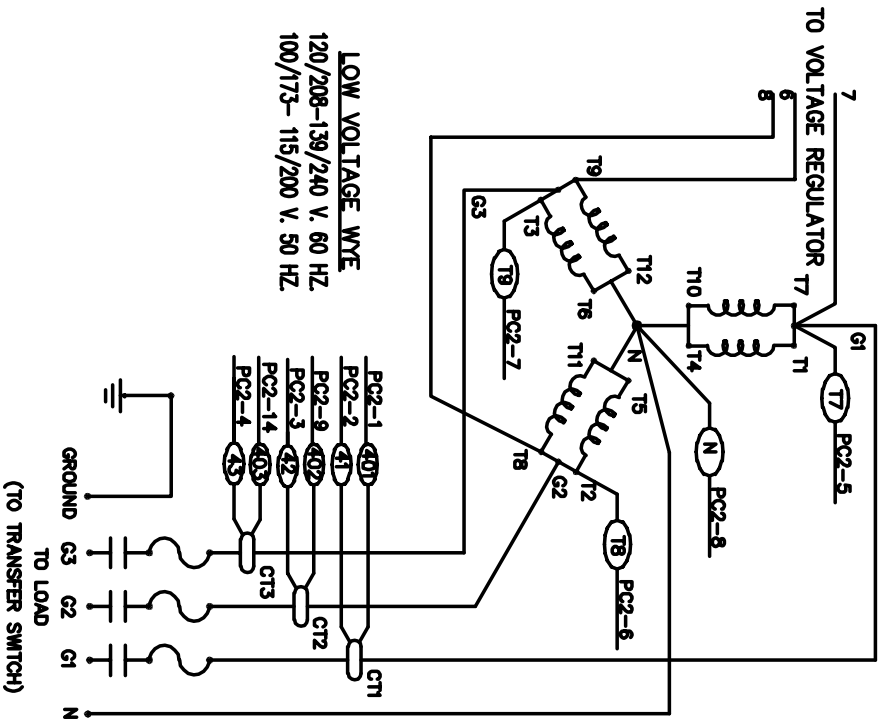

# PSS50LS-17/C,D,E

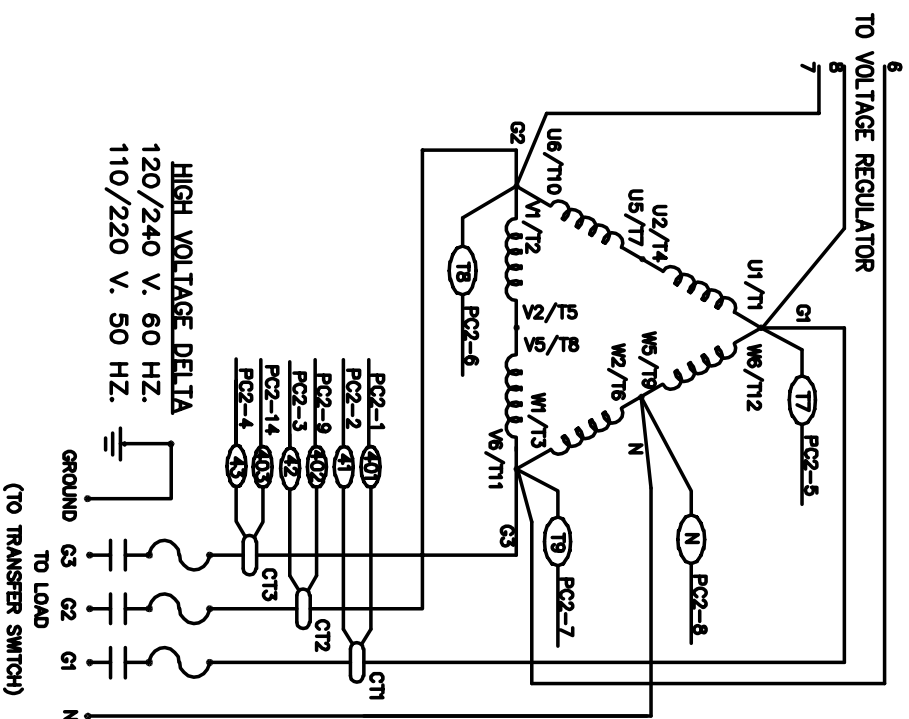

# "LCS" SERIES GOVERNOR (ORIGINAL DESIGN)

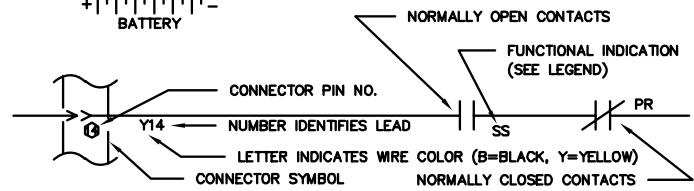
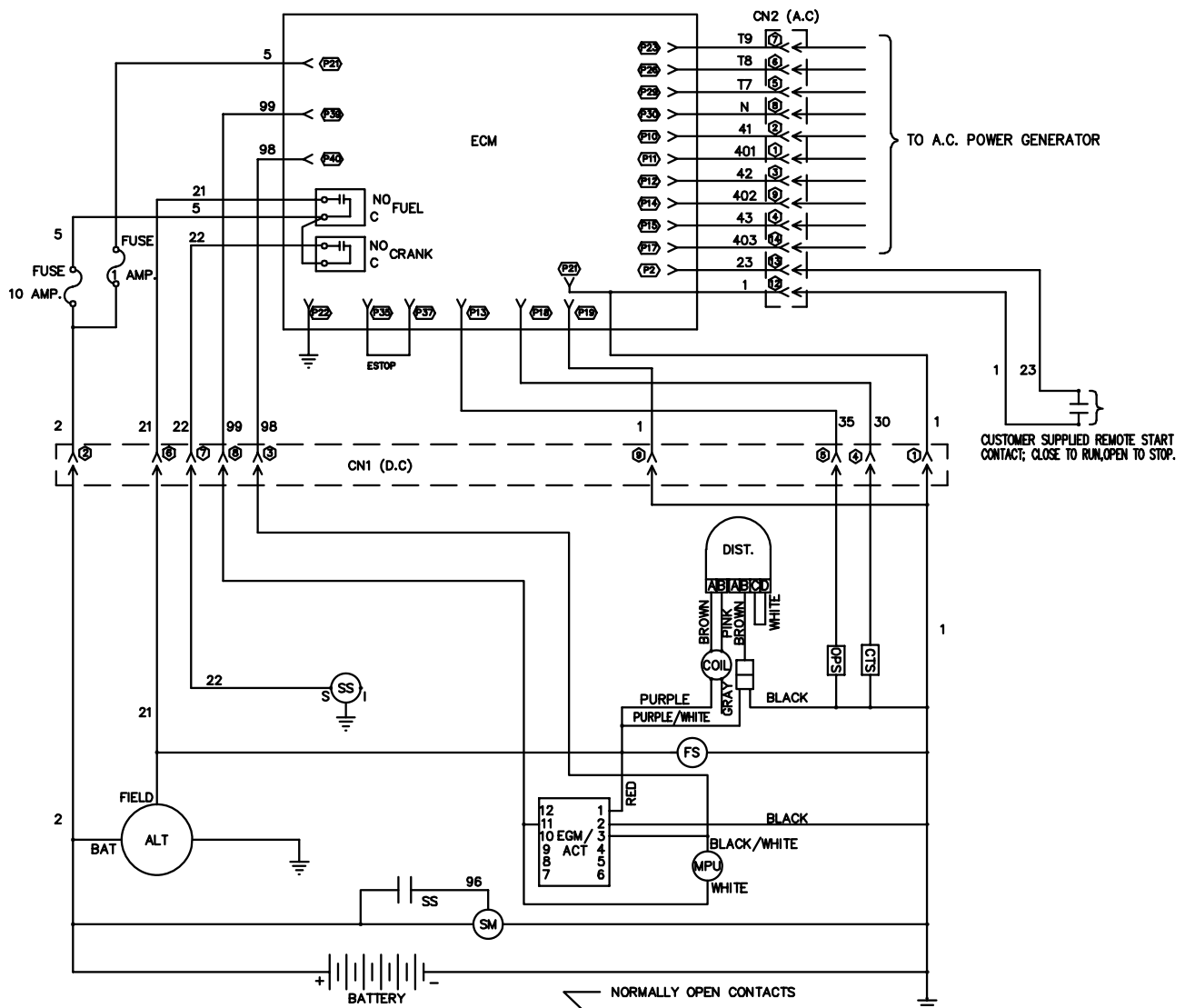

- LEGEND**
- |         |                                       |
|---------|---------------------------------------|
| ALT     | ALTERNATOR                            |
| CN1,CN2 | WIRING HARNESS CONNECTORS             |
| CTS     | COOLANT TEMPERATURE SENDER            |
| DIST.   | ENGINE IGNITION DISTRIBUTOR           |
| ECM     | ENGINE CONTROL MODULE                 |
| EGM/ACT | ELECTRONIC GOVERNOR MODULE / ACTUATOR |
| FS      | FUEL SOLENOID                         |
| GND     | GROUND (CHASSIS OR FRAME)             |
| MPU     | MAGNETIC PICKUP UNIT                  |
| OPS     | OIL PRESSURE SENDER                   |
| SS      | ENGINE STARTER MOTOR SOLENOID         |
| SM      | ENGINE STARTER MOTOR                  |

## DC WIRING SCHEMATIC

# “L” SERIES GOVERNOR (WITH NEW GOVERNOR REPLACEMENT)

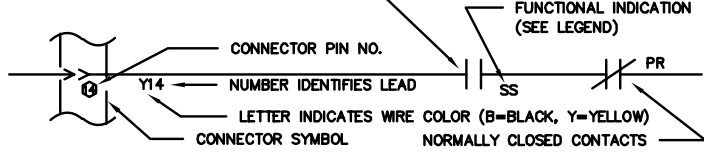
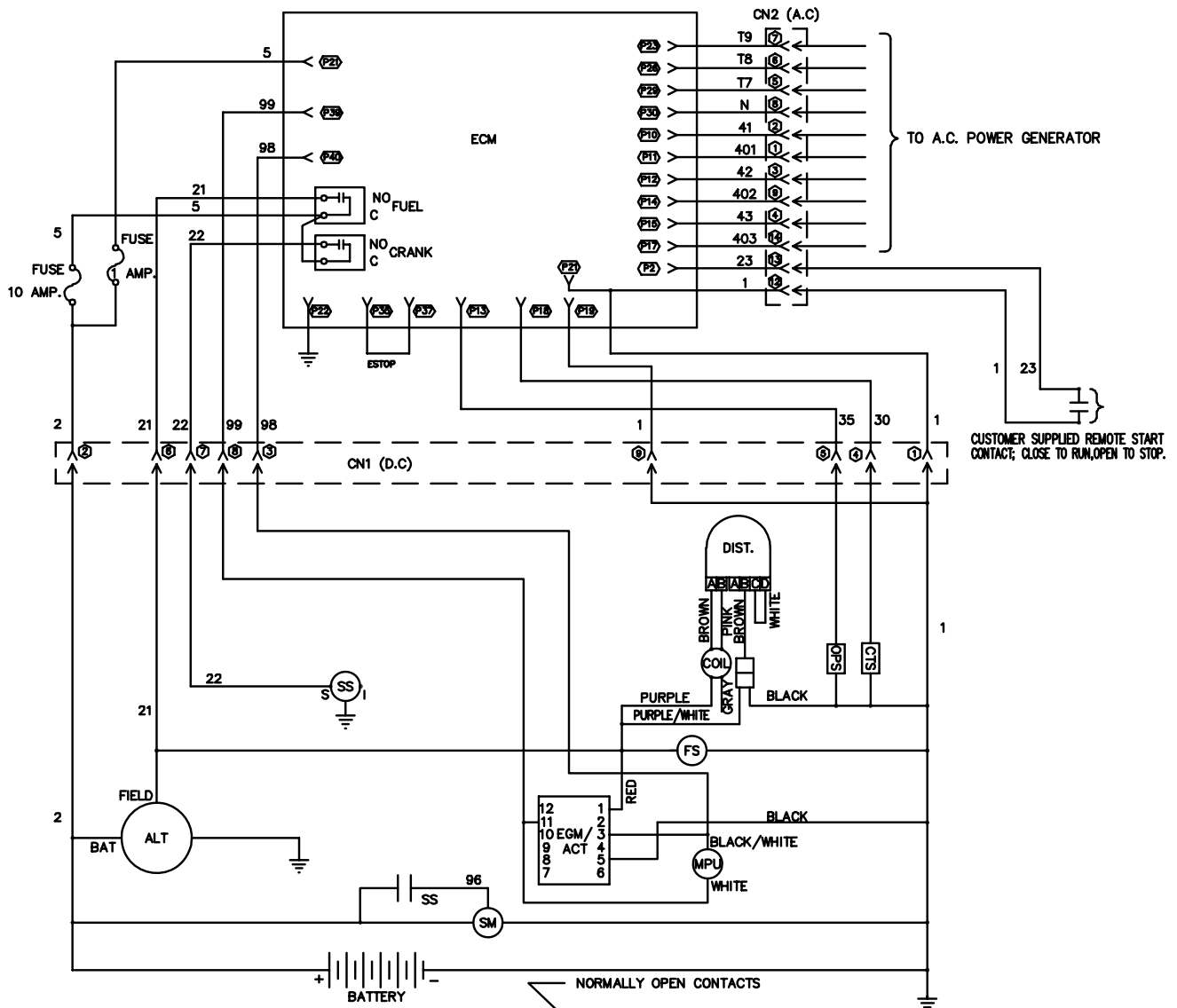

- LEGEND**
- ALT ALTERNATOR
  - CN1,CN2 WIRING HARNESS CONNECTORS
  - CTS COOLANT TEMPERATURE SENDER
  - DIST. ENGINE IGNITION DISTRIBUTOR
  - ECM ENGINE CONTROL MODULE
  - EGM/ACT ELECTRONIC GOVERNOR MODULE / ACTUATOR
  - FS FUEL SOLENOID
  - GND GROUND (CHASSIS OR FRAME)
  - MPU MAGNETIC PICKUP UNIT
  - OPS OIL PRESSURE SENDER
  - SS ENGINE STARTER MOTOR SOLENOID
  - SM ENGINE STARTER MOTOR

## DC WIRING SCHEMATIC