

**ILLUSTRATED  
PARTS LIST**

**W145FPTOT-4/B**

**W145FPTOT-17/B**

**W145FPTOT-18/A**

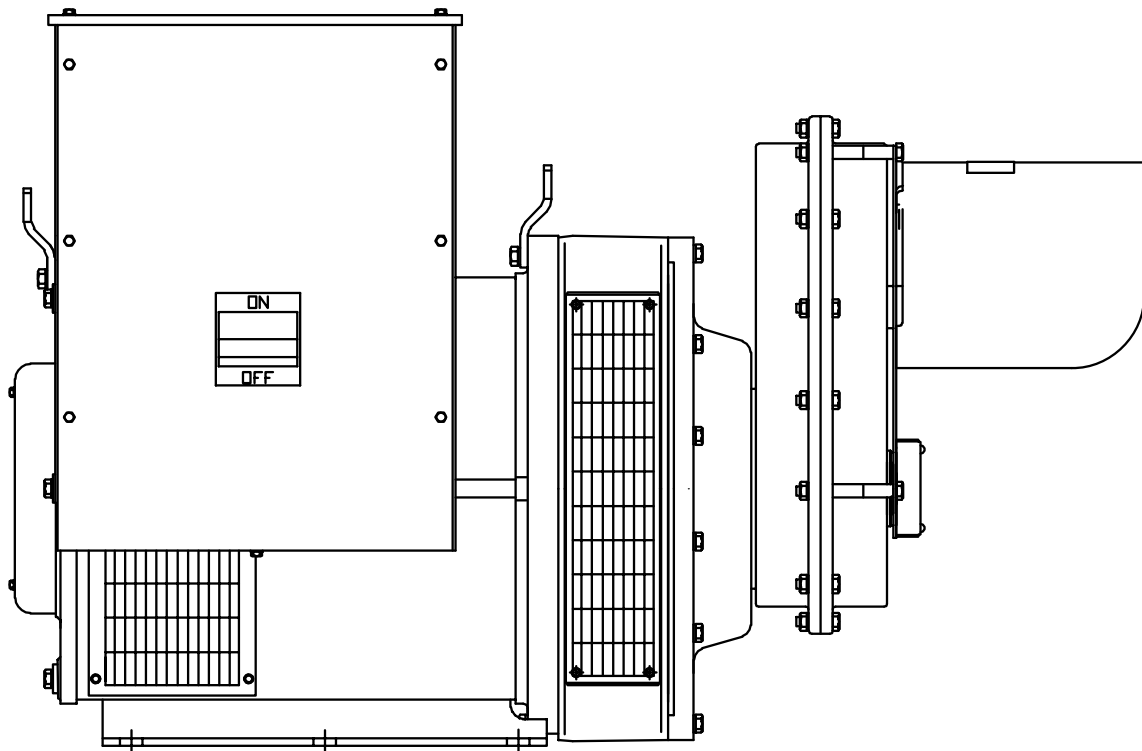

# GENERATOR ASSEMBLY W145FPTOT-4/B

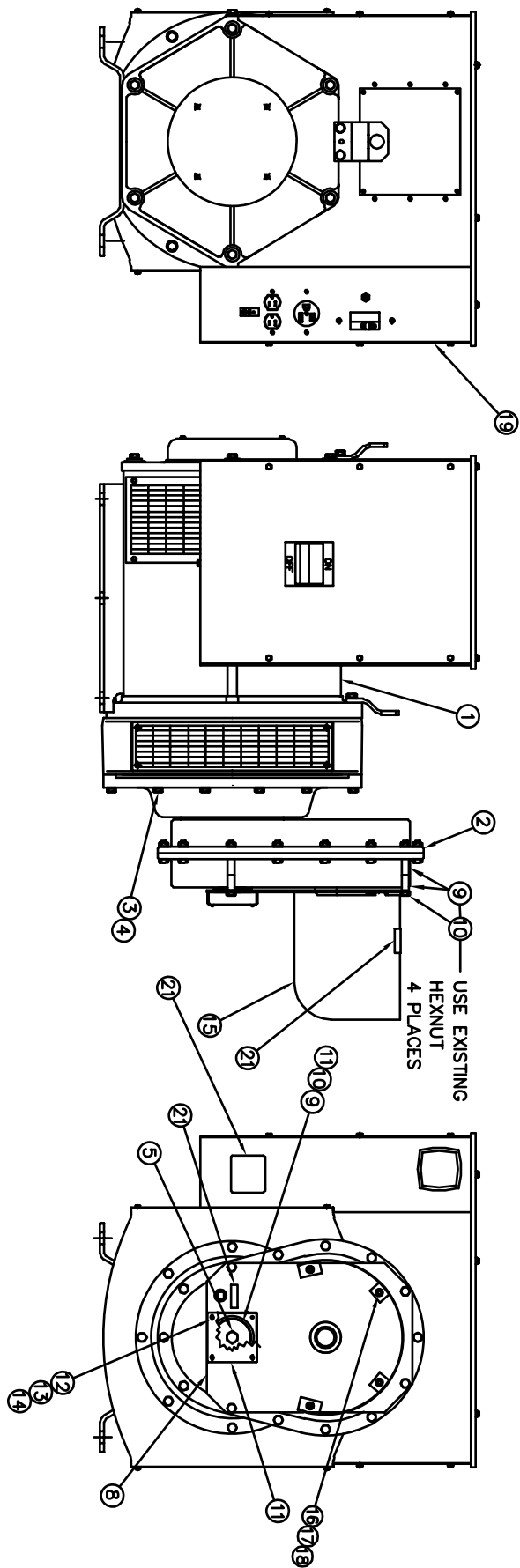

# GENERATOR ASSEMBLY W145FPTOT-4/B

25	1744-000	4	1/2-13 HEXNUT (SHIPPING)
24	21867-000	4	1/2 FLATWASHER (SHIPPING)
23	A-61603-005	4	1/2-13 X 2-1/2 CARRIAGE BOLT (SHIPPING)
22	60706-160	1	OPERATOR'S MANUAL
21	B-64894-005	1	DECAL AND NAMEPLATE INSTALLATION
20	93542-011	1	LEAD WIRE ASSEMBLY
19	B-300173-8	1	MAIN LINE BREAKER PANEL INSTALLATION
18	A-16249-000	4	5/16-18 HEX FLANGENUT
17	526-000	4	5/16 FLAT WASHER
16	465-000	4	5/16-18 X 7/8 HEX HEAD BOLT
15	S-7606	1	PTO SHAFT GUARD
14	484-000	4	#10 SPLIT LOCKWASHER
13	456-000	4	#10-24 HEX NUT
12	A-52464-002	4	#10-32 X 1-1/2 ROUND HEAD SCREW
11	A-300105	1	LOWER SHAFT GUARD
10	A-91658-015	4	3/8-16 X 4 HEX HEAD BOLT
9	A-62825-004	8	SPACER
8	A-300104	1	PTO SHAFT GUARD SUPPORT PLATE
7	A-300096	1	SHAFT WASHER
6	A-300106-1	1	BELLEVILLE WASHER, 5/8"
5	A-350096-35	1	M16-2.00 X 35MM HEX HEAD BOLT
4	A-97436-010	12	M10 SPLIT LOCKWASHER
3	A-94282-035	12	M10 X 1.25 X 35 MM HEX HEAD BOLT
2	B-300100-2	1	GEARCASE
1	B-351811-4	1	GENERATOR
ITEM	PART NO	QUAN.	DESCRIPTION



225 S. CORDOVA AVE.  
LECENTER, MN 56057  
507-357-6821  
SERVICE DEPT.  
507-357-6831

STAMFORD NEWAGE GENERATOR  
INFORMATION:

MODEL: UCI274F2L TWO BEARING

[www.cumminsgeneratortechnologies.com](http://www.cumminsgeneratortechnologies.com)

# MAIN LINE CIRCUIT BREAKER ASSEMBLY W145FPTOT-4/B

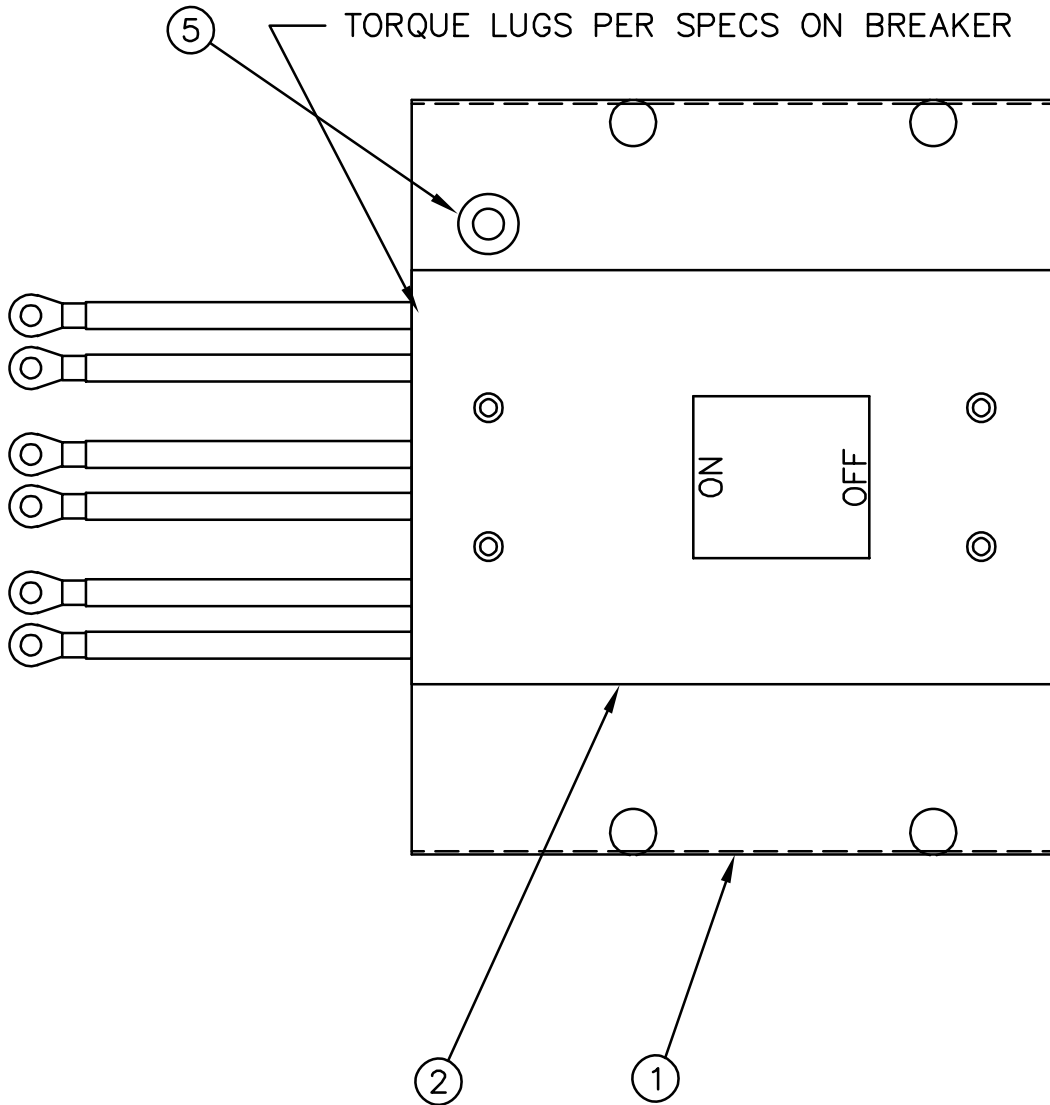

6	100019-405	.012	COPPER SHIM STOCK (.005)
5	A-23917-000	1	GROMMET
4	A-300114	9.5FT	LEAD WIRE (3/0 AWG)
3	99823-001	6	TERMINAL LUG
2	A-350289-2	1	CB, 500 AMP, 3 POLE
1	A-300174	1	PANEL, MLB
ITEM	PART NO	QUAN.	DESCRIPTION

# CIRCUIT BREAKER ASSEMBLY W145FPTOT-4/B

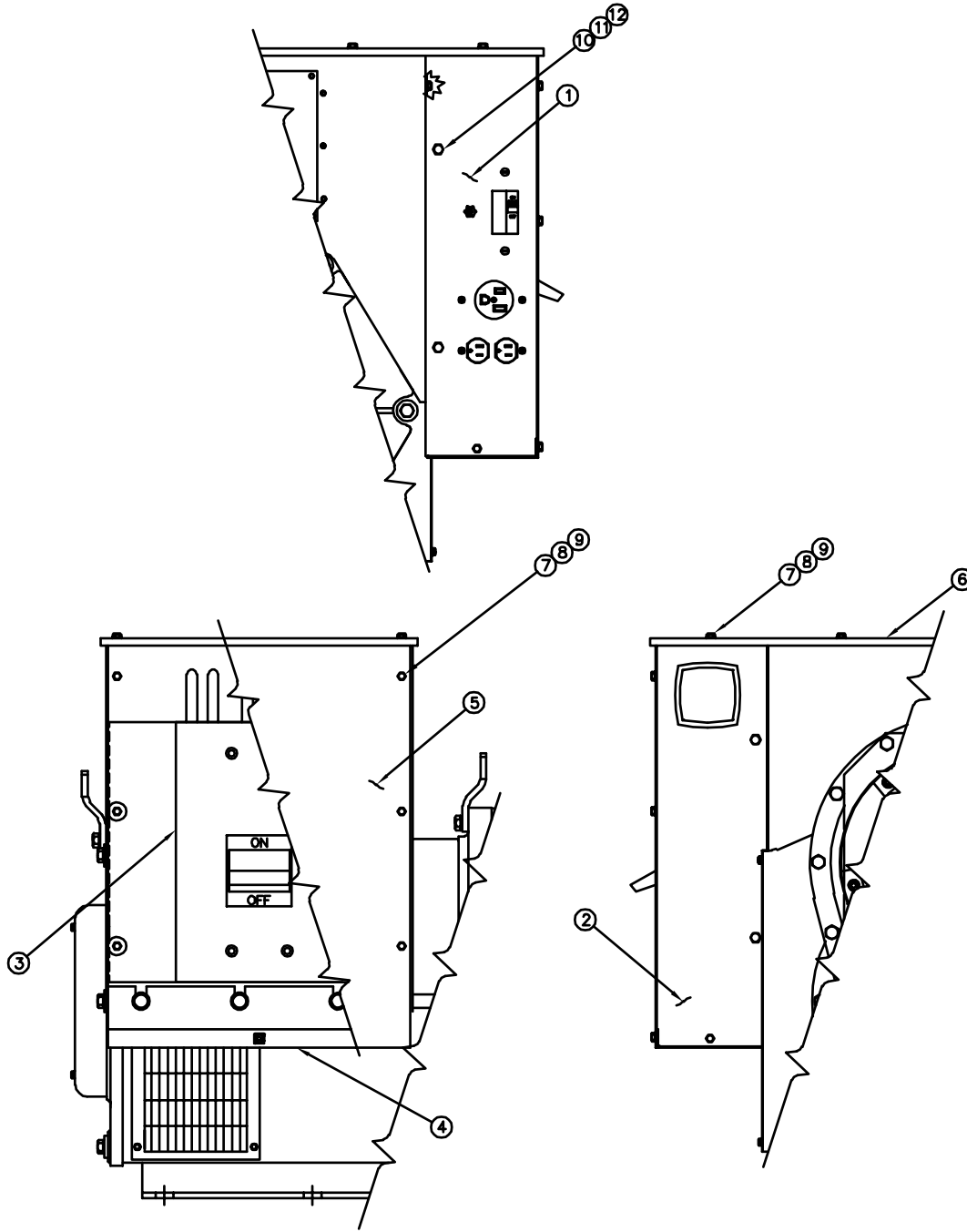

12	481-000	4	3/8 SPLIT LOCKWASHER
11	A-92914-000	4	3/8-16 HEXNUT
10	A-91658-011	4	3/8-16 X 3/4 HEX HEAD BOLT
9	479-000	11	1/4 SPLIT LOCKWASHER
8	476-000	11	1/4-20 X 5/8 HEX HEAD BOLT
7	A-92495-001	11	1/4-20 SQUARE RETAINER NUT
6	A-300170	1	TERMINAL BOX TOP
5	A-300168	1	CIRCUIT BREAKER COVER PLATE
4	B-300167-1	1	TERMINAL BOX BOTTOM
3	A-300173-7	1	MAIN LINE CIRCUIT BREAKER ASSEMBLY
2	A-300171-1	1	REAR PANEL ASSEMBLY
1	B-300184	1	RECEPTACLE PANEL ASSEMBLY
ITEM	PART NO	QUAN.	DESCRIPTION

# REAR PANEL AND RECEPTACLE PANEL ASSEMBLY W145FPTOT-4/B & W145FPTOT-17/B

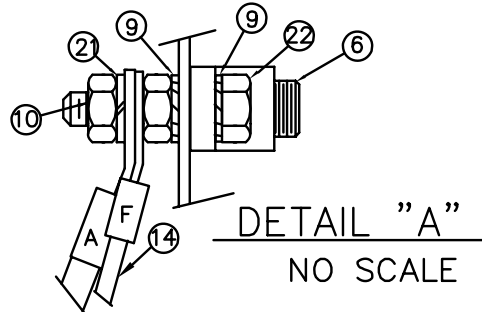
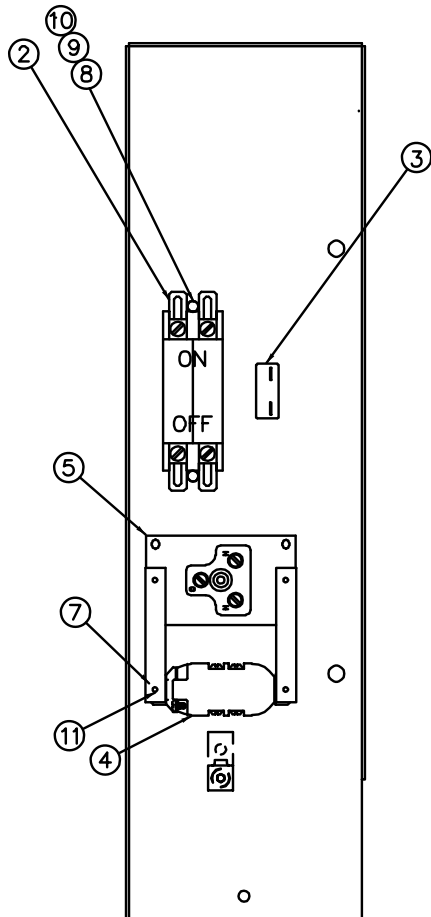

23	49975-010	2	TIE-WRAPS
22	439-000	1	HHCS 1/4-20 X 1
21	479-000	1	1/4 SPLIT LOCK WASHER
20	91320-002	2	LUG
19	91457-000	1	LUG
18	7547-000	1	LUG
17	4155-000	2	LUG
16	48602-001	2	LUG
15	21850-002	2	LUG
14	91780-000	6.92FT	LEAD WIRE 8 GA BLACK
13	91815-000	4.42FT	LEAD WIRE 14 GA BLACK
12	64638-000	3.5 FT	LEAD WIRE 10 GA GREEN
11	21698-001	4	# 10 SHEET METAL SCREW
10	638-000	4	HN 1/4-20
9	4516-000	4	1/4 EXTERNAL TOOTH LOCK WASHER
8	463-000	2	HHCS, 1/4-20 x 1/2
7	B-64045-002	2	STRIP, MOUNTING
6	A-63708	1	TERMINAL LUG
5	57325-000	1	RECEPTACLE, 50 AMP, 250 VOLT
4	A-50766-000	1	RECEPTACLE, 20A, 125 VOLT
3	A-91286-001	1	CB, 20 AMP, 1P
2	A-57030-000	1	CB, 50 AMP, 2P
1	B-300169-1	1	EXTENSION, LEFT TERMINAL BOX
ITEM	PART NO	QUAN.	DESCRIPTION

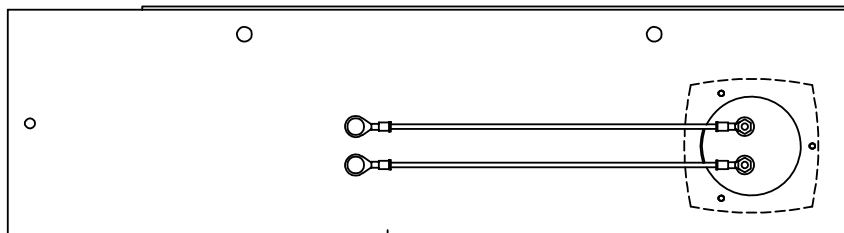

5	A-91457-002	2	TERMINAL LUG
4	A-12624	2.5FT	LEAD WIRE (16 GA.)
3	4158	2	TERMINAL LUG
2	A-300102	1	FREQUENCY METER
1	A-300169-2	1	EXTENSION, RIGHT TERMINAL BOX
ITEM	PART NO	QUAN.	DESCRIPTION

# DECAL INSTALLATION

## W145FPTOT-4/B & W145FPTOT-17/B

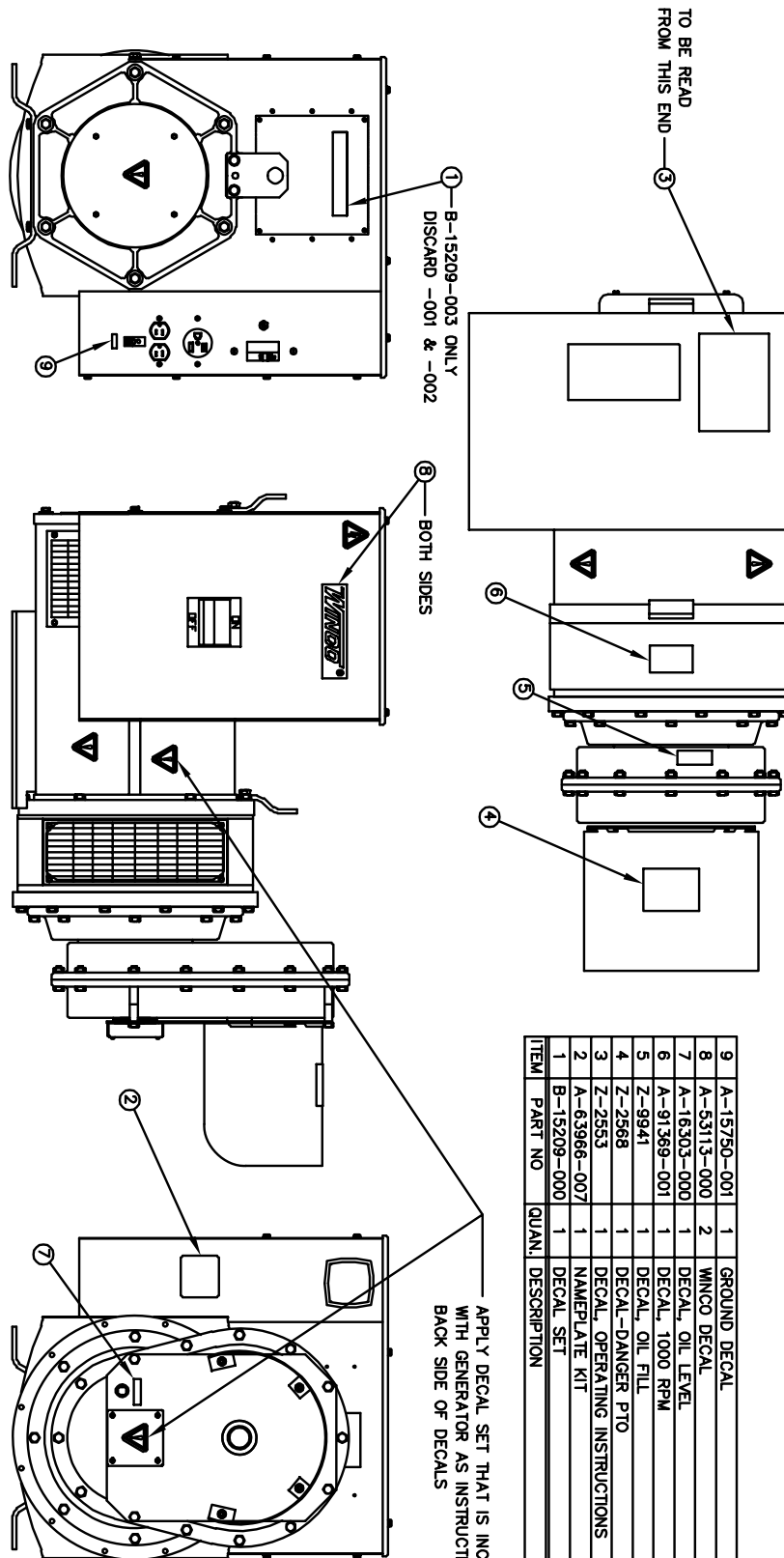

ITEM	PART NO	QUAN	DESCRIPTION
9	A-15750-001	1	GROUND DECAL
8	A-53113-000	2	MINCO DECAL
7	A-16303-000	1	DECAL, OIL LEVEL
6	A-91369-001	1	DECAL, 1000 RPM
5	Z-9941	1	DECAL, OIL FILL
4	Z-2568	1	DECAL-DANGER PTO
3	Z-2553	1	DECAL-OPERATING INSTRUCTIONS
2	A-63966-007	1	NAMEPLATE KIT
1	B-15209-000	1	DECAL SET

APPLY DECAL SET THAT IS INCLUDED WITH GENERATOR AS INSTRUCTED ON BACK SIDE OF DECALS

# WIRING DIAGRAM W145FPTOT-4/B

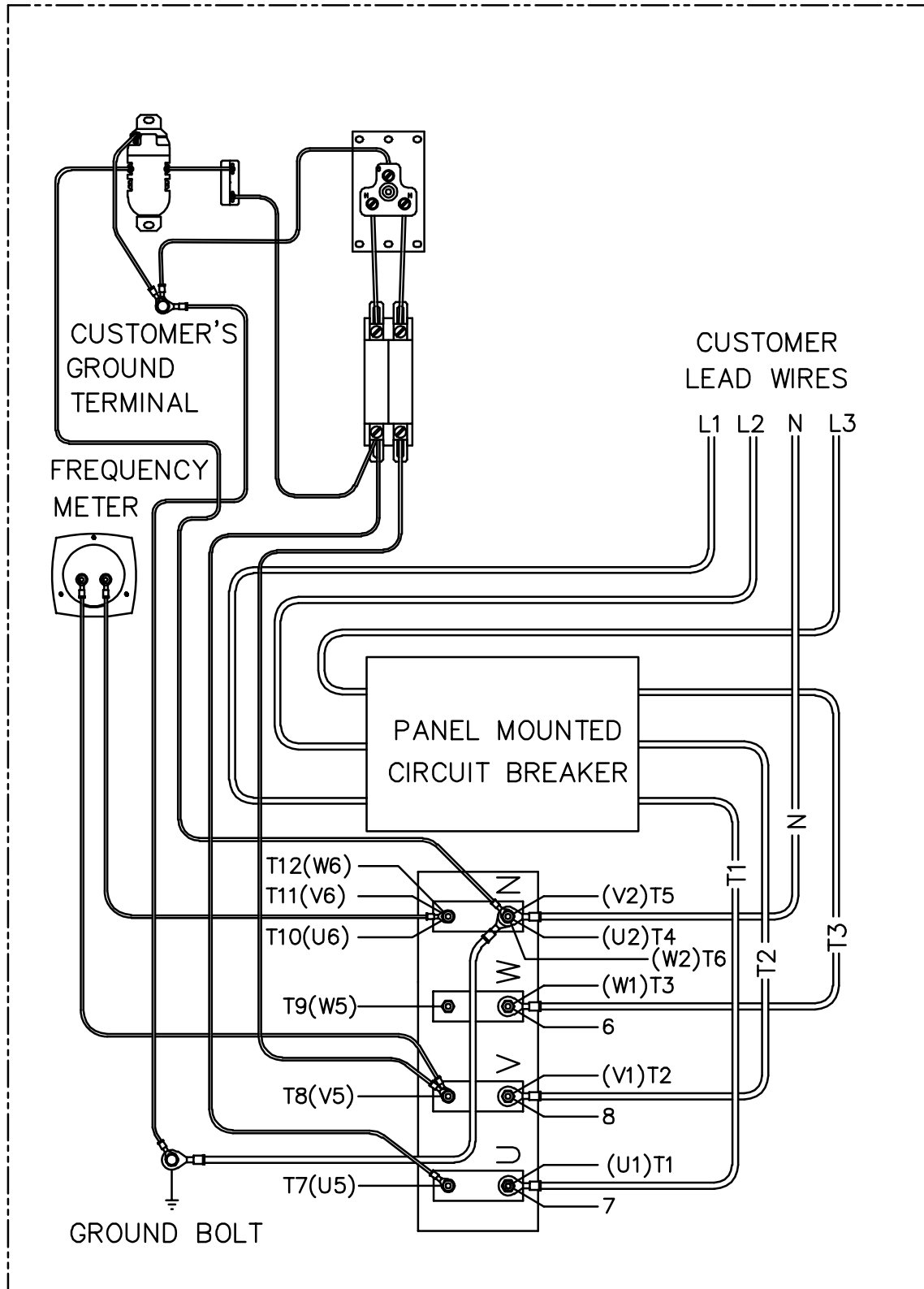

WIRING DIAGRAM (THREE PHASE WYE "12 WIRE"; 120/208)

# GENERATOR ASSEMBLY W145FPTOT-17/B

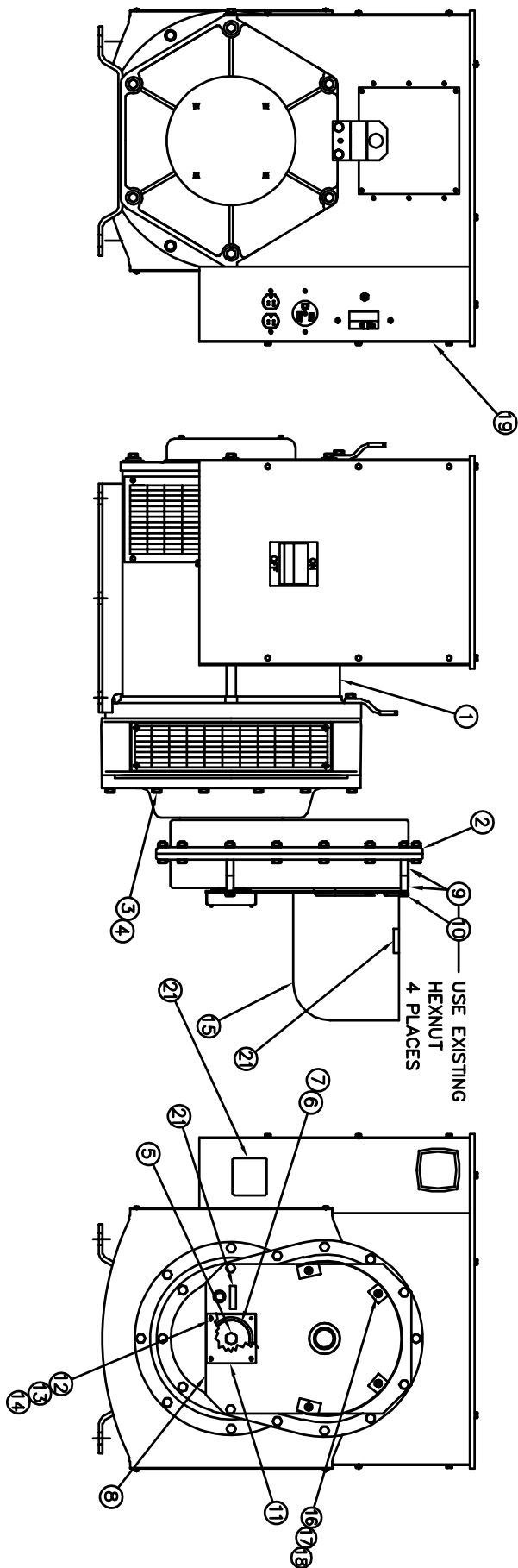

# GENERATOR ASSEMBLY W145FPTOT-17/B

25	1744-000	4	1/2-13 HEXNUT (SHIPPING)
24	21867-000	4	1/2 FLATWASHER (SHIPPING)
23	A-61603-005	4	1/2-13 X 2-1/2 CARRIAGE BOLT (SHIPPING)
22	60706-160	1	OPERATOR'S MANUAL
21	B-64894-005	1	DECAL AND NAMEPLATE INSTALLATION
20	B-52118-041	1	LEAD WIRE ASSEMBLY
19	B-300173-9	1	MAIN LINE BREAKER PANEL INSTALLATION
18	A-16249-000	4	5/16-18 HEX FLANGENUT
17	526-000	4	5/16 FLAT WASHER
16	465-000	4	5/16-18 X 7/8 HEX HEAD BOLT
15	S-7606	1	PTO SHAFT GUARD
14	484-000	4	#10 SPLIT LOCKWASHER
13	456-000	4	#10-24 HEX NUT
12	A-52464-002	4	#10-32 X 1-1/2 ROUND HEAD SCREW
11	A-300105	1	LOWER SHAFT GUARD
10	A-91658-015	4	3/8-16 X 4 HEX HEAD BOLT
9	A-62825-004	8	SPACER
8	A-300104	1	PTO SHAFT GUARD SUPPORT PLATE
7	A-300096	1	SHAFT WASHER
6	A-300106-1	1	BELLEVILLE WASHER, 5/8"
5	A-350096-50	1	M16-2.00 X 50MM HEX HEAD BOLT
4	A-97436-010	12	M10 SPLIT LOCKWASHER
3	A-94282-035	12	M10 X 1.50 X 35 MM HEX HEAD BOLT
2	B-300100-2	1	GEARCASE
1	B-351811-4	1	GENERATOR
ITEM	PART NO	QUAN.	DESCRIPTION



225 S. CORDOVA AVE.  
LECENTER, MN 56057  
507-357-6821  
SERVICE DEPT.  
507-357-6831

STAMFORD NEWAGE GENERATOR  
INFORMATION:

MODEL: UCI274F2L TWO BEARING

[www.cumminsgeneratortechnologies.com](http://www.cumminsgeneratortechnologies.com)

# MAIN LINE CIRCUIT BREAKER ASSEMBLY W145FPTOT-17/B

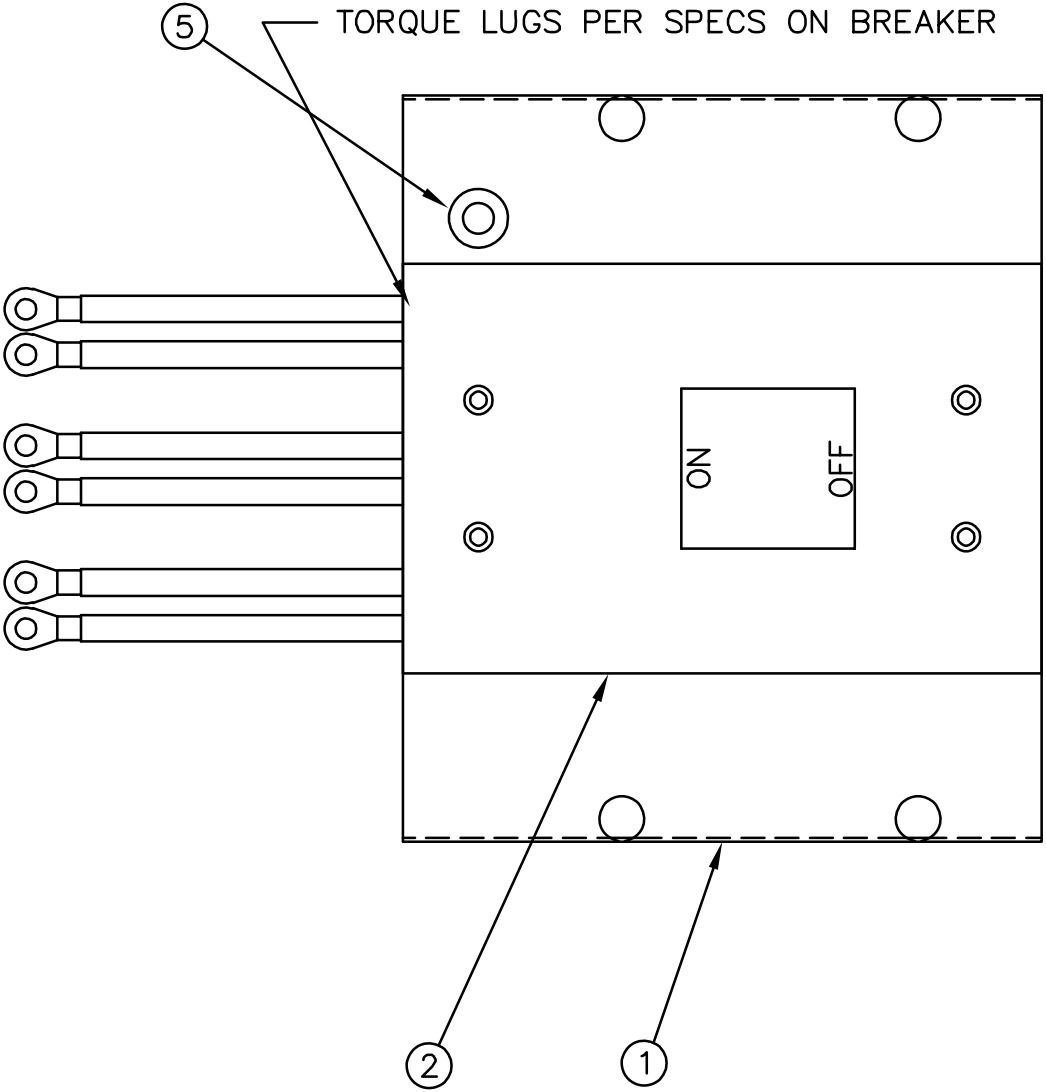

5	A-23917-000	1	GROMMET
4	B-91450-000	8.8FT	LEAD WIRE (#1 AWG)
3	A-91321-000	6	TERMINAL LUG
2	A-350289-1	1	CB, 450 AMP, 3 POLE
1	A-300174	1	PANEL, MLB
ITEM	PART NO	QUAN.	DESCRIPTION

# CIRCUIT BREAKER ASSEMBLY W145FPTOT-17/B

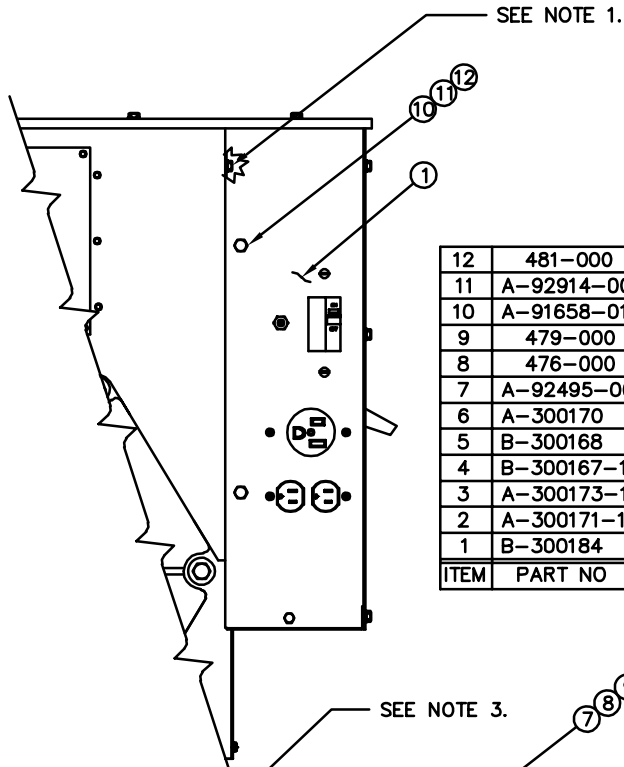

12	481-000	4	3/8 SPLIT LOCKWASHER
11	A-92914-000	4	3/8-16 HEXNUT
10	A-91658-011	4	3/8-16 X 3/4 HEX HEAD BOLT
9	479-000	11	1/4 SPLIT LOCKWASHER
8	476-000	11	1/4-20 X 5/8 HEX HEAD BOLT
7	A-92495-001	11	1/4-20 SQUARE RETAINER NUT
6	A-300170	1	TERMINAL BOX TOP
5	B-300168	1	CIRCUIT BREAKER COVER PLATE
4	B-300167-1	1	TERMINAL BOX BOTTOM
3	A-300173-1	1	MAIN LINE CIRCUIT BREAKER ASSEMBLY
2	A-300171-1	1	REAR PANEL ASSEMBLY
1	B-300184	1	RECEPTACLE PANEL ASSEMBLY
ITEM	PART NO	QUAN.	DESCRIPTION

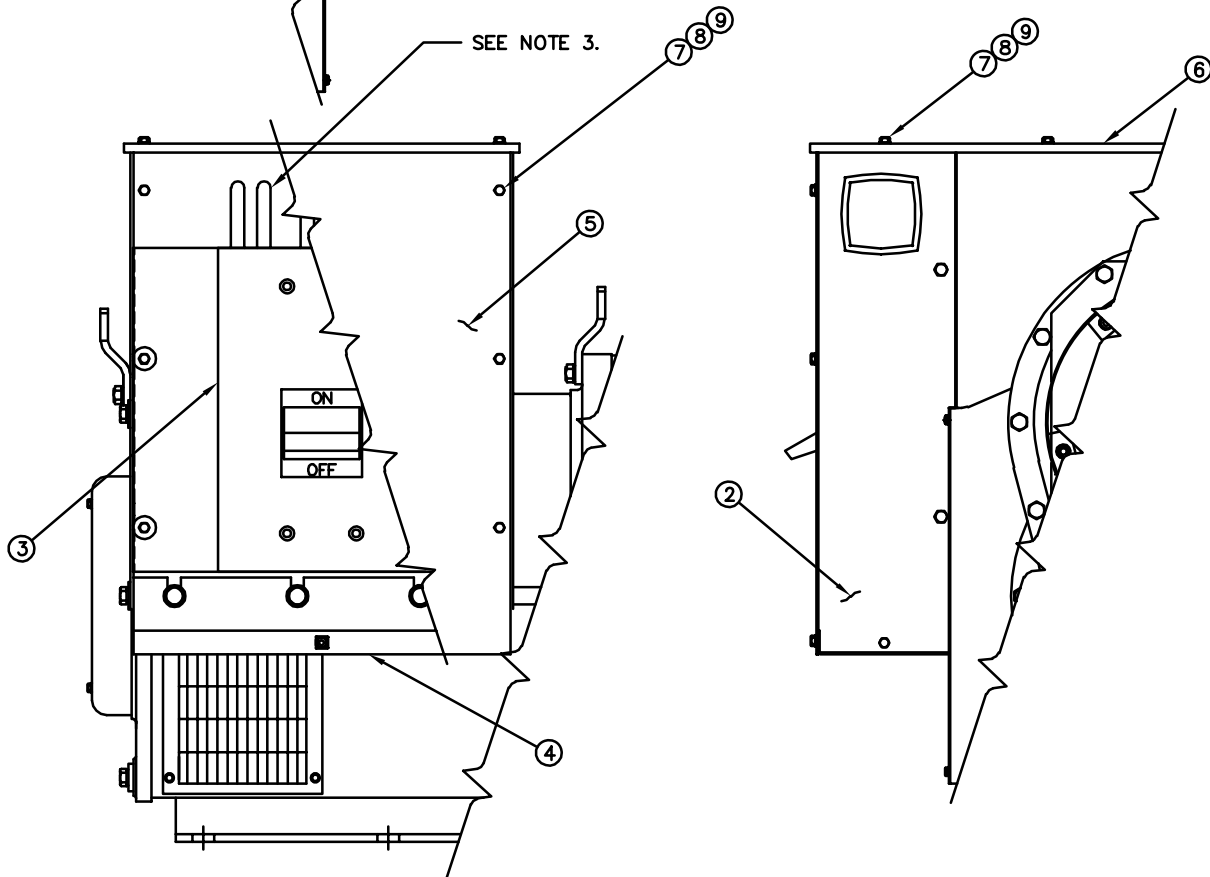

# WIRING DIAGRAM W145FPTOT-17/B

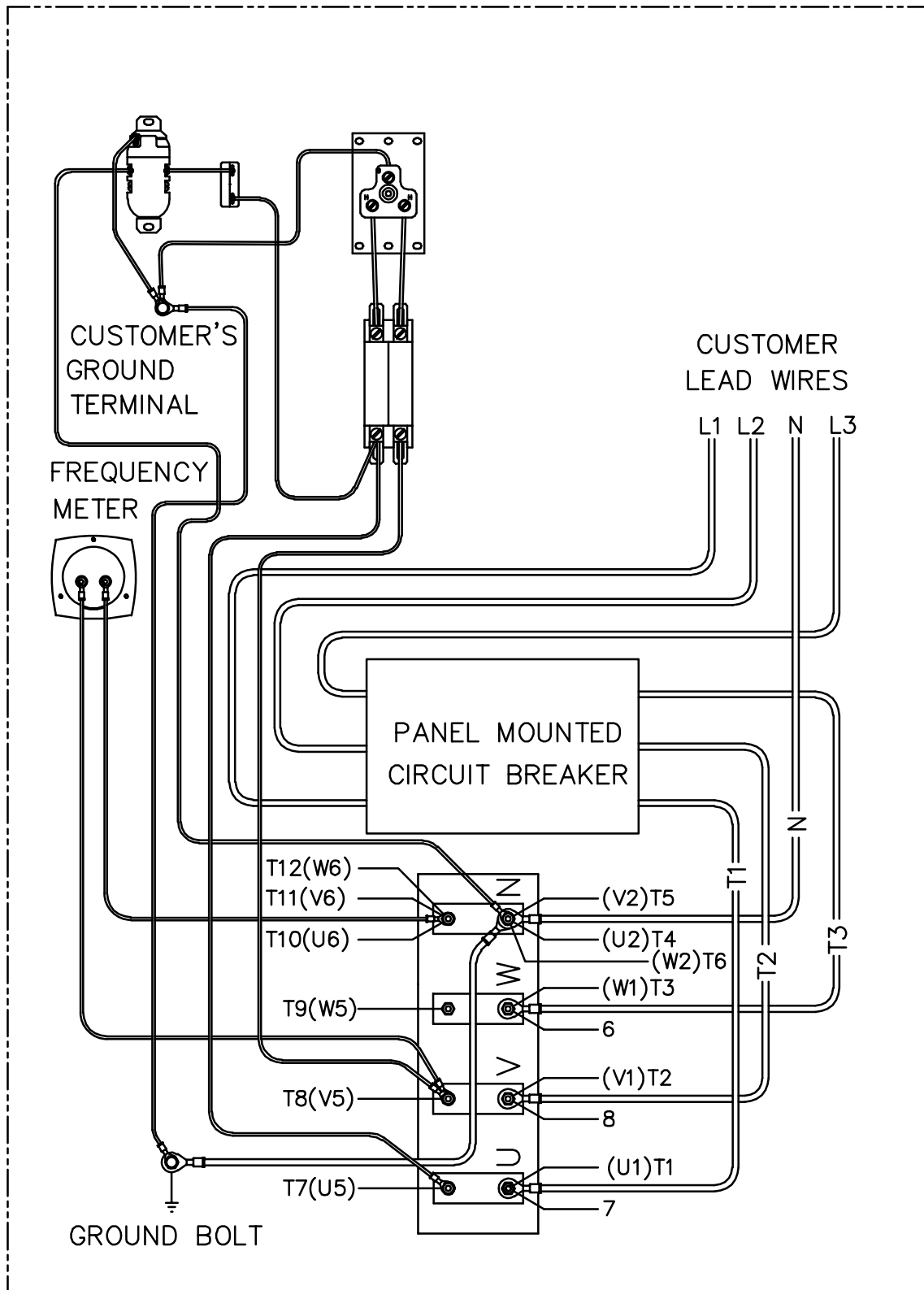

WIRING DIAGRAM (THREE PHASE WYE "12 WIRE"; 120/208)

# GENERATOR ASSEMBLY W145FPTOT-18/A

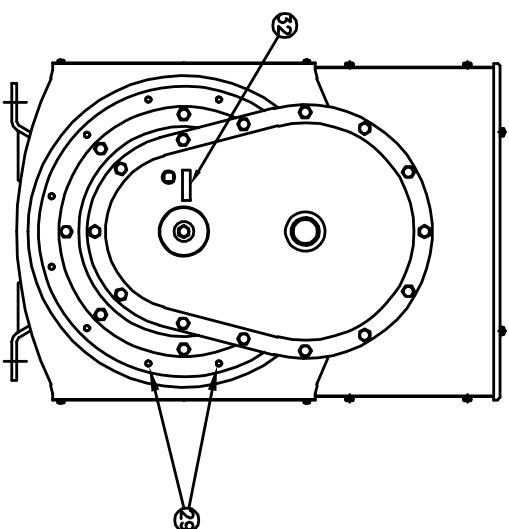
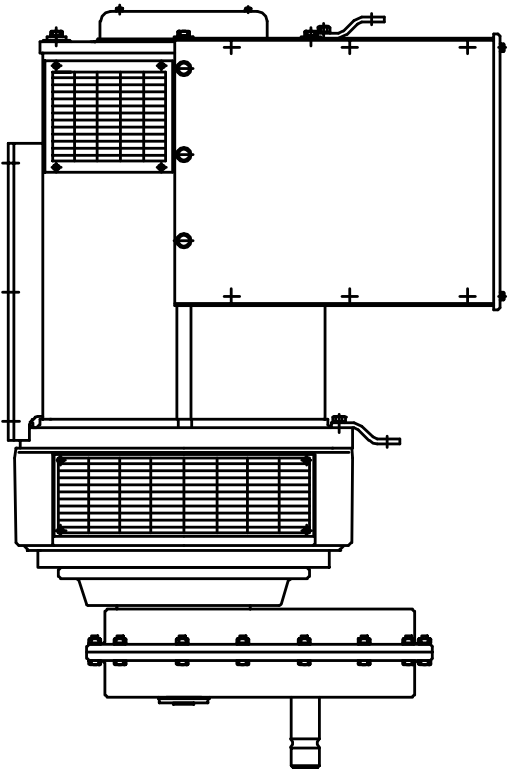
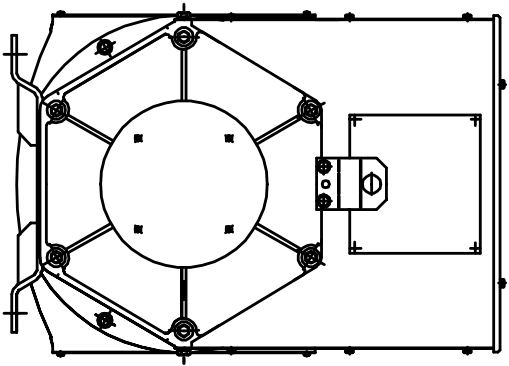

STAMFORD NEWAGE GENERATOR  
INFORMATION:

MODEL: UC1274F1L TWO BEARING

[www.cumminsgeneratortechnologies.com](http://www.cumminsgeneratortechnologies.com)

# GENERATOR ASSEMBLY W145FPTOT-18/A

32	A-16303-000	1	DECAL, OIL LEVEL
30	92914-000	20	3/8-16 HEX NUT
29	A-91658-008	4	HHCS 3/8-16 X 2 3/4
28	91369-001	1	SPEED DECAL
27	1744-000	4	1/2 -13 HEX NUT
26	21867-000	4	1/2 FLAT WASHER
25	61603-005	4	1/2 BOLT
24	60706-160	1	OPERATORS MANUAL
23	B-15209	1	DECAL, WARNING SET
22	Z-2568	2	DECAL
21	Z-2553	1	DECAL
20	Z-9941	1	DECAL, OIL FILL
19	53113-000	2	DECAL
18	63966-003	1	NAMEPLATE
17	526	4	FW 5/16
16	A-480	4	SLW 5/16
15	458	4	HN 5/16-18
14	1116	4	HHCS 5/16-18 x 1
13	484	4	SLW #10
12	6372	4	HN #10-32
11	A-52464-2	4	RHMS #10-32 x 1 1/2
10	A-91658-15	4	HHCS 3/8-16 x 4
9	A-481	20	SLW 3/8
8	A-91658-007	16	HHCS 3/8-16 x 2 1/2
7	A-91083-1	1	HHCS 5/8-11 x 1 1/2
6	A-62825-4	8	SPACER
5	A-300106-1	1	BELLEVILLE WASHER, 5/8"
4	A-350174-60	8	SHCS, M16-2.0 x 60MM
3	A-300101-11	1	ASSEMBLY, MLB PANEL (225 AMP)
2	B-300107	1	KIT, GEAR CASE
1	B-350004-710	1	GENERATOR
ITEM	PART NO	QUAN.	DESCRIPTION

# CIRCUIT BREAKER ASSEMBLY W145FPTOT-18/A

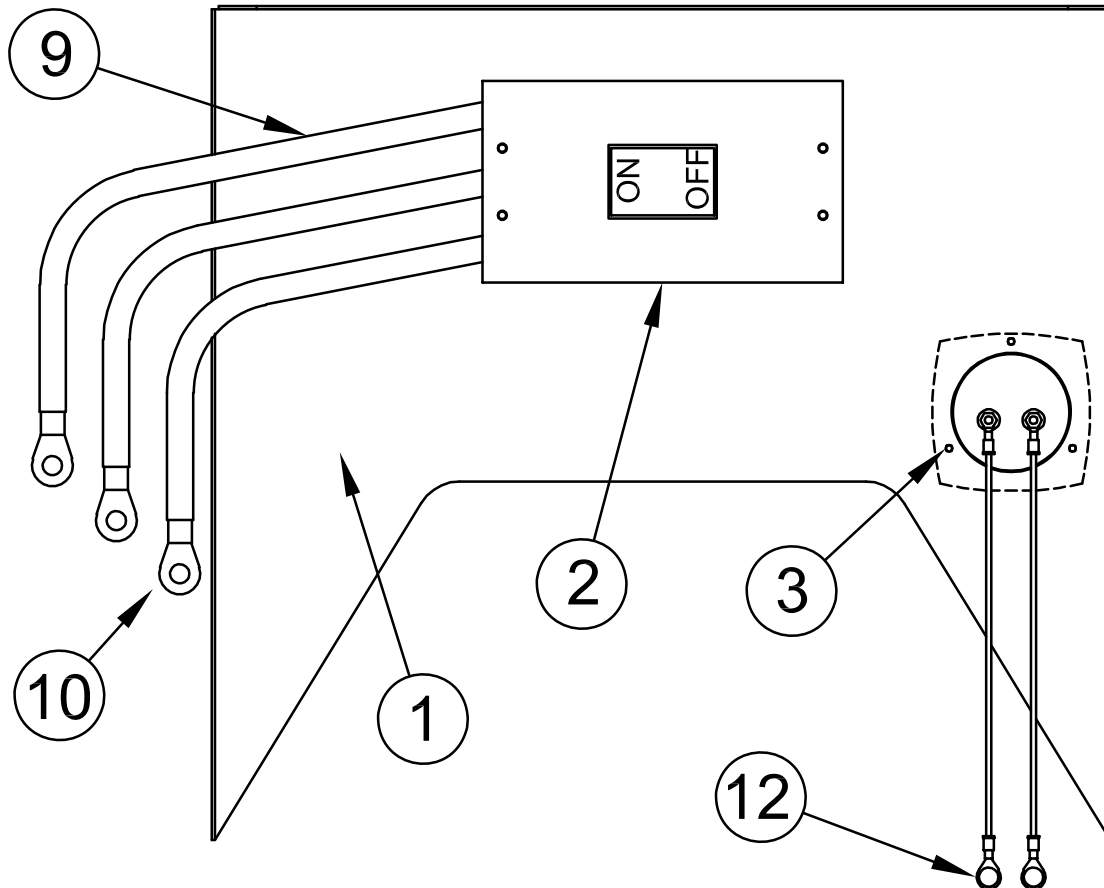

12	A-91457-002	2	TERMINAL LUG
11	A-12624	1.7FT	LEAD WIRE (16 GA.)
10	4158	2	TERMINAL LUG
9	B-91450	4.4FT	LEAD WIRE (#1 AWG)
8	A-91321	3	TERMINAL LUG
7	598	4	FW #10
6	484	4	SLW #10
5	6372	4	HN 10-32
4	24864	4	RHMS 10-32 x 4 1/2
3	A-300102	1	FREQUENCY METER
2	A-81097-014	1	CB, 225 AMP, 3 POLE, 480 VOLT
1	B-350098-3	1	PANEL, MLB
ITEM	PART NO	QUAN.	DESCRIPTION

# WIRING DIAGRAM W145FPTOT-18/A

PANEL MOUNTED METER

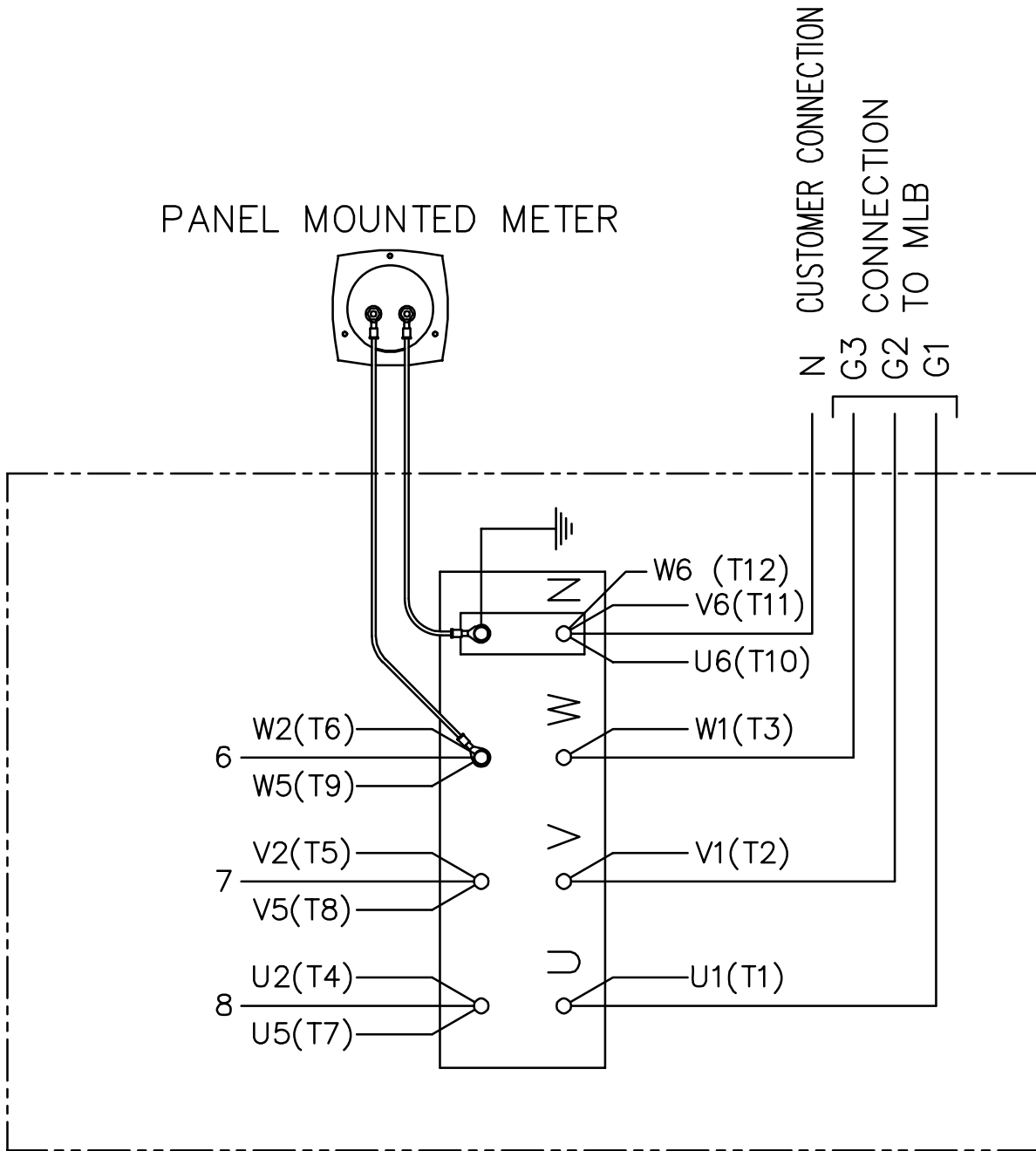

CONNECTION DIAGRAM (3 $\phi$  SERIES WYE; 277/480)